

جهاز شؤون البيئة
المشروع المصرى للحد من التلوث

دليل الرصد الذاتى
صناعة الغزل والنسيج

يناير ٢٠٠٣

- -

-

- -

- -

- -

-

-

-

-

-

-

-

-

-

-

-

-

-

-

-

-

-

-

-

-

-

-

-

-

EMS

- -

- -

- -

-

- -

- -

-

-

-

-

-

-

- -

Mass balance

- -

Emission factors

- -

- -

-

-

-

-

-

-

-

-

-

-

-

-

-

-

- -

- -

- -

- -

- -

- -

()

()

()

(EPAP)

(FINNIDA)

EPAP FINNIDA

:

:

:

:

:

(EPAP-) GIM

1-1

EPAP



--

--

SIC

--

--

)

)

)

.(

(

(

%

.(

)

%

%

%

%

-

:

۱-۲

(-)

- -

.

.

.

.

--

.....

(Surfactant)

()

.....

--

-

:

	<p>()</p> <p>)</p> <p>(</p> <p>_____</p>
	<p>(... -)</p> <p>_____</p> <p>_____</p>

--

()

:

.

()

.

()

.

.

.

.

()

						-	
						()	

()

		(COD) (BOD)	()				
) (
) (
				()			

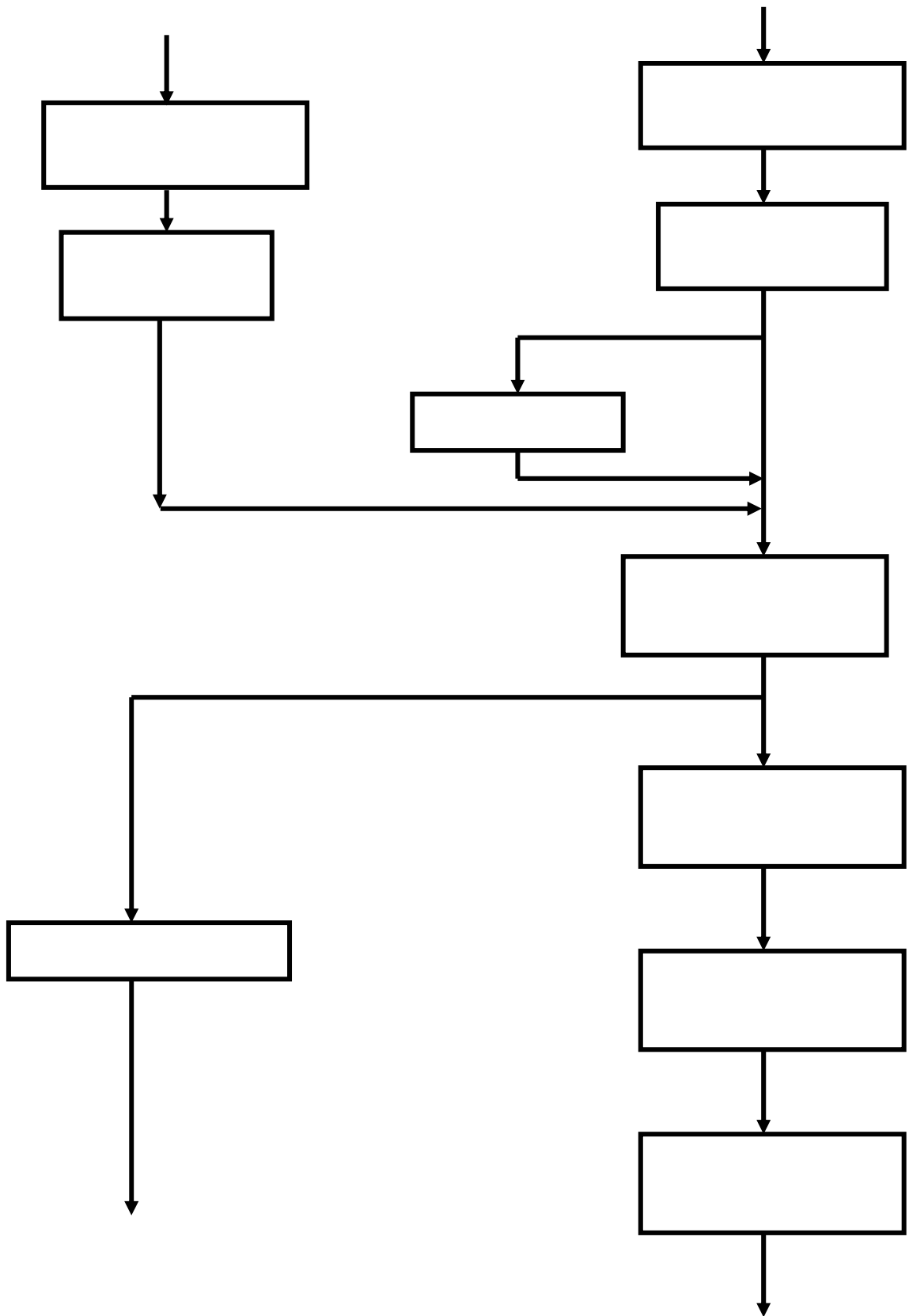

()

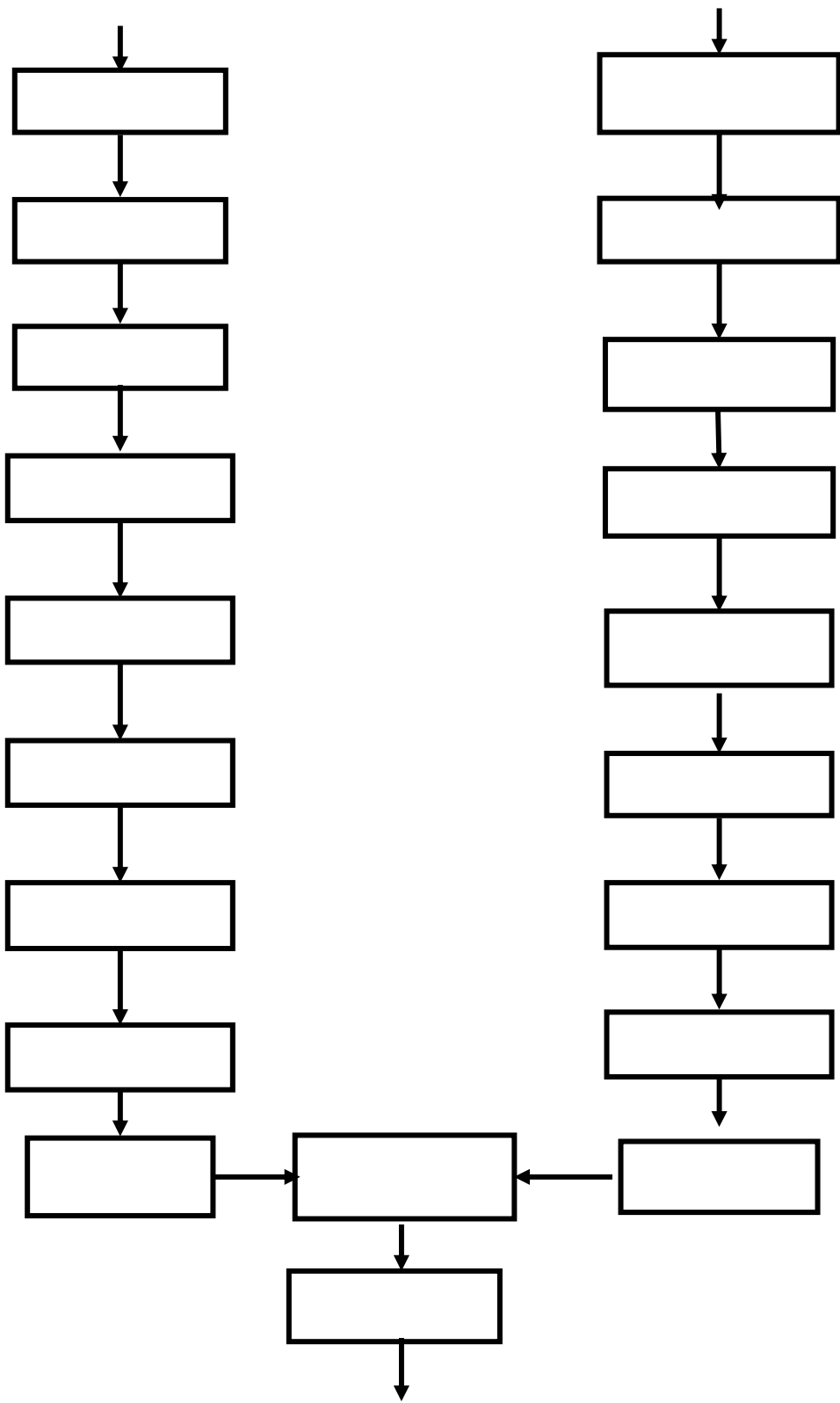

()

(-)

()

(warp beam)

(cloth beam)

()

()

()

()

		(BOD,COD)) (PVA			-	

()

		_____)	
		_____				(..	
	-	_____)	
						-	
						(..	

()

		_____				- -) (..	

		_____	_____				

()

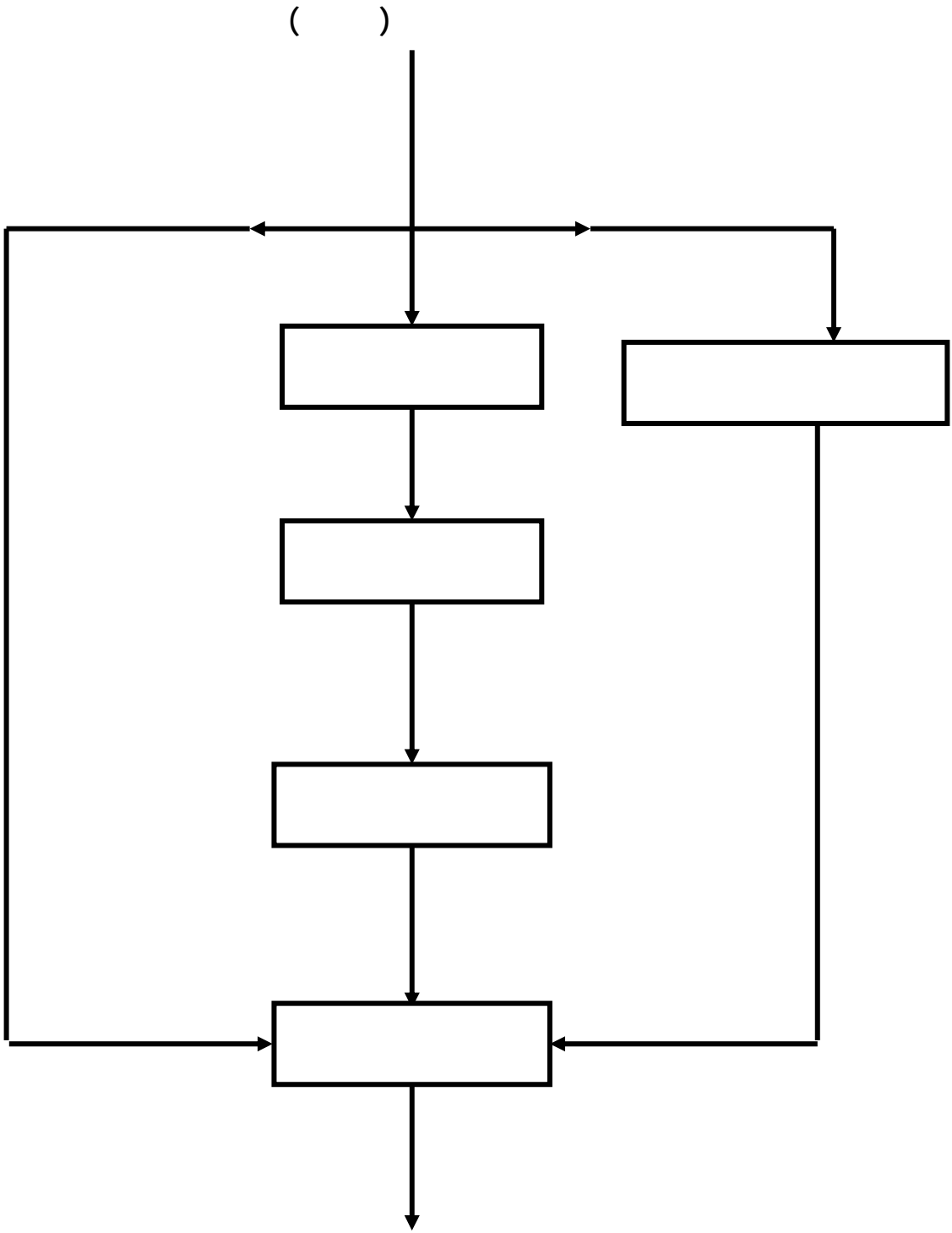

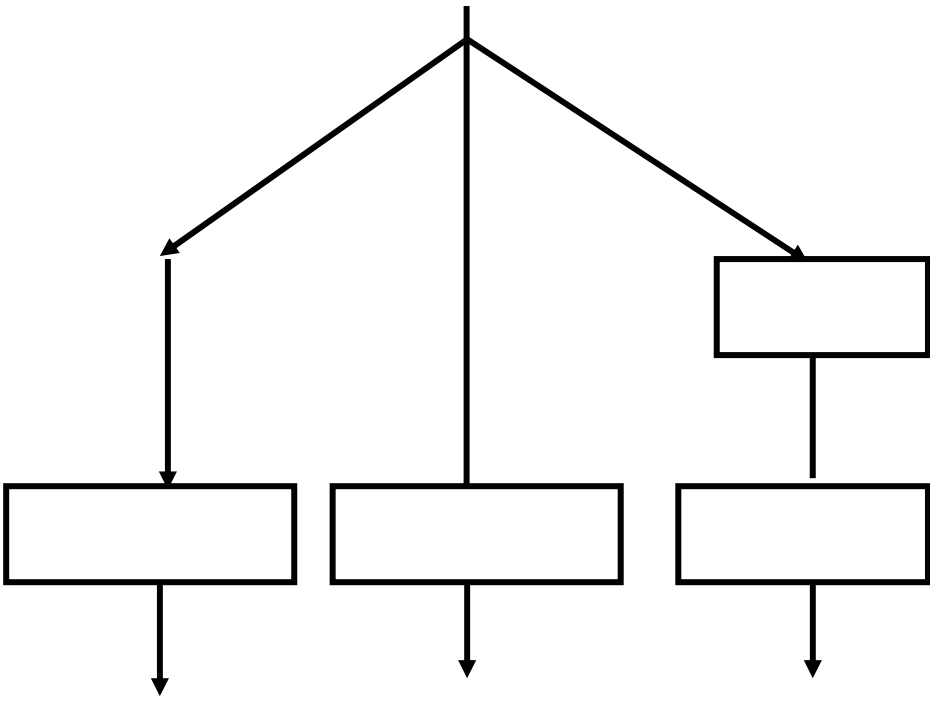

()

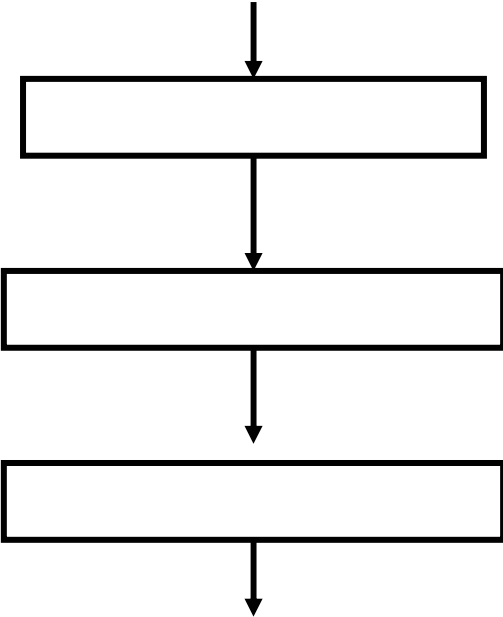

()

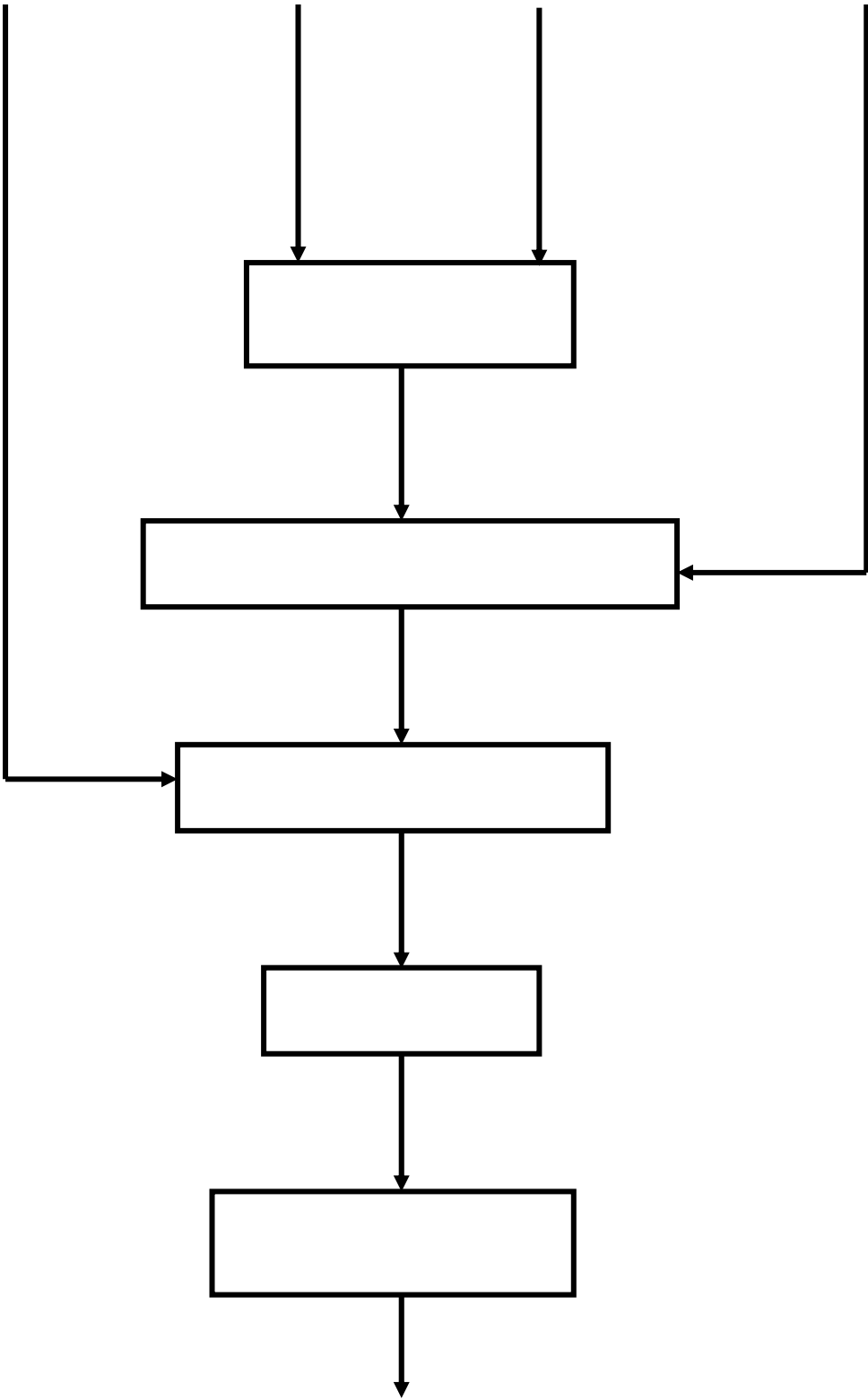

()

()

()

()

()

:

()

()

()

.....

.

.....

.

()

()

.

.

.

.

.

() ()

		_____					()
) (
	.	- - - -				- - - -	
		- - -) (

() -

		-					
		-				-	
)		-	- ()			-	
-		-	-)			-	
-		-	-)			-	
-		-	- (-	
		-				-	

() -

-()	-	- - -	- -			- .. -	-) - (

	_____	_____	_____				()
-							

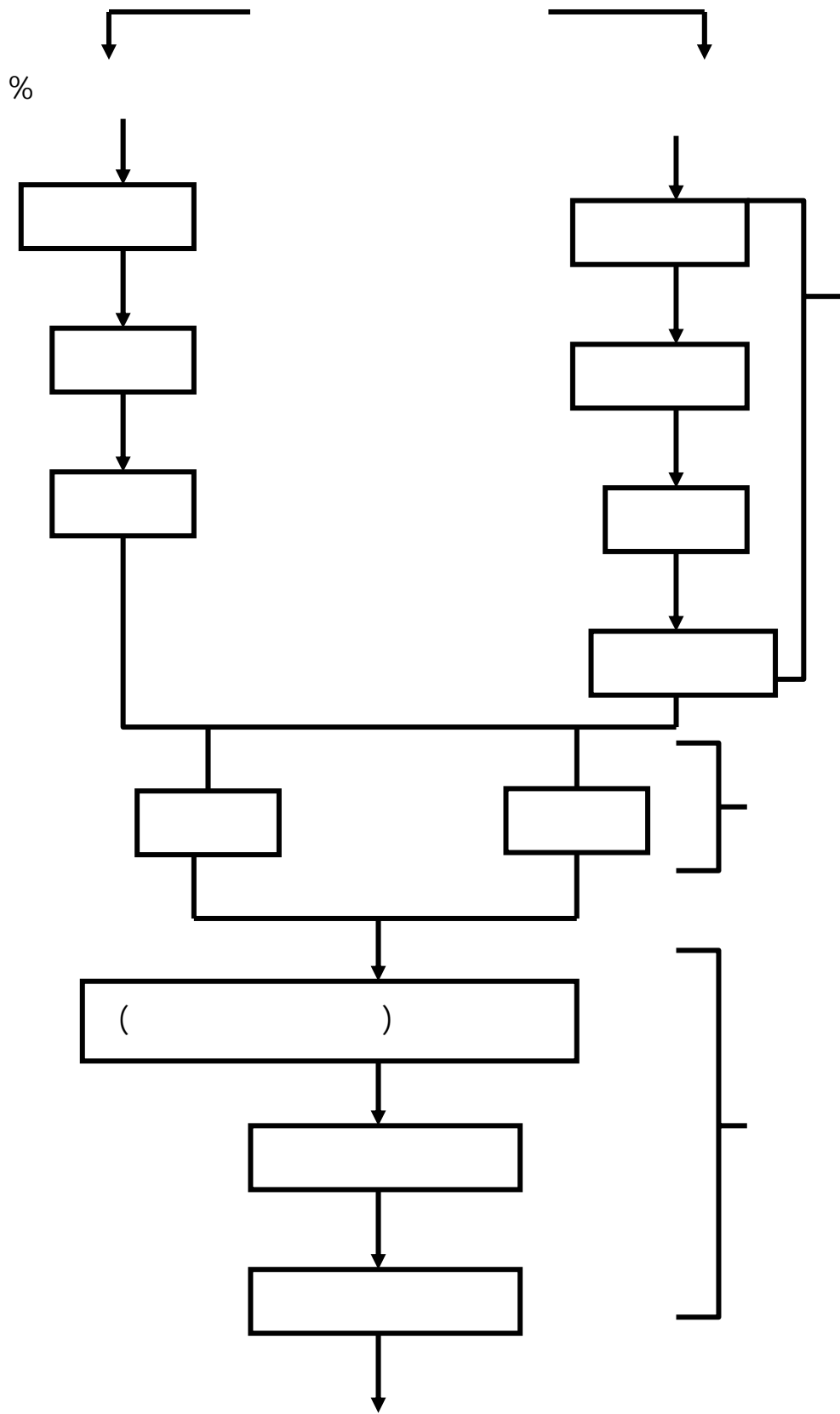

%

()

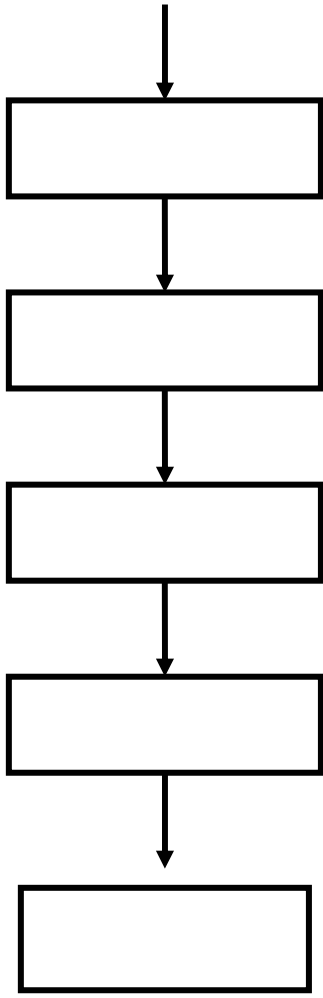

()

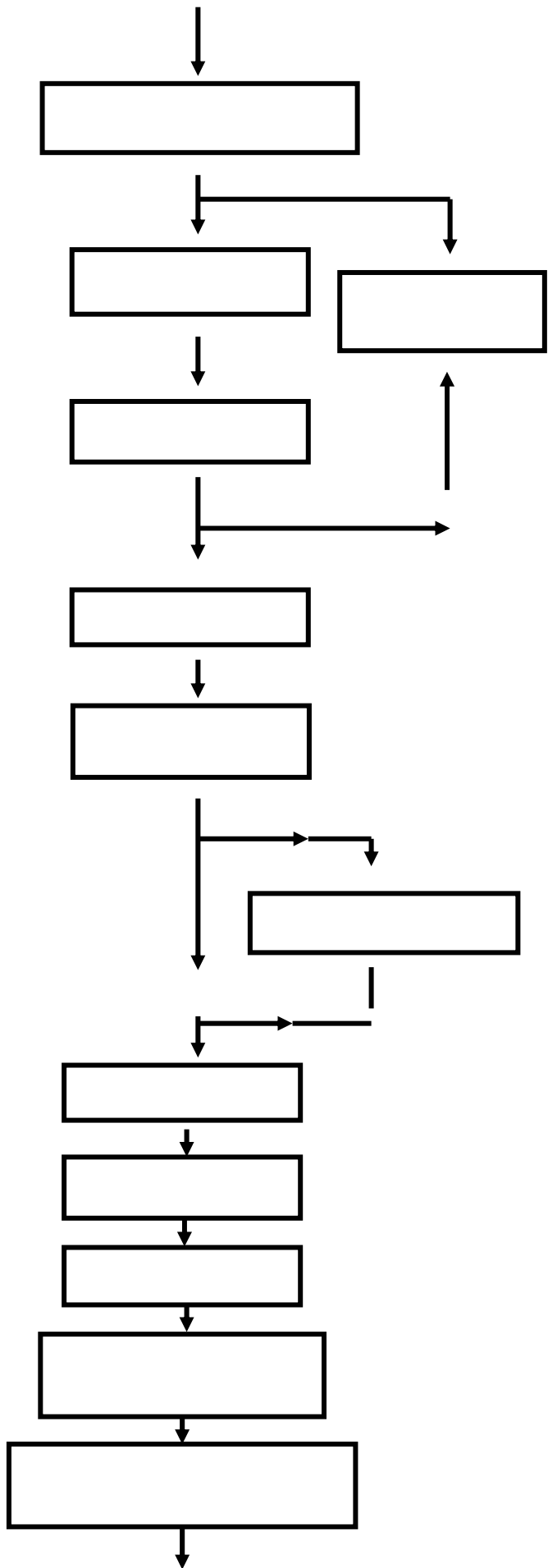

--

()

()

:

()

) (
	-						
						- -	
-							

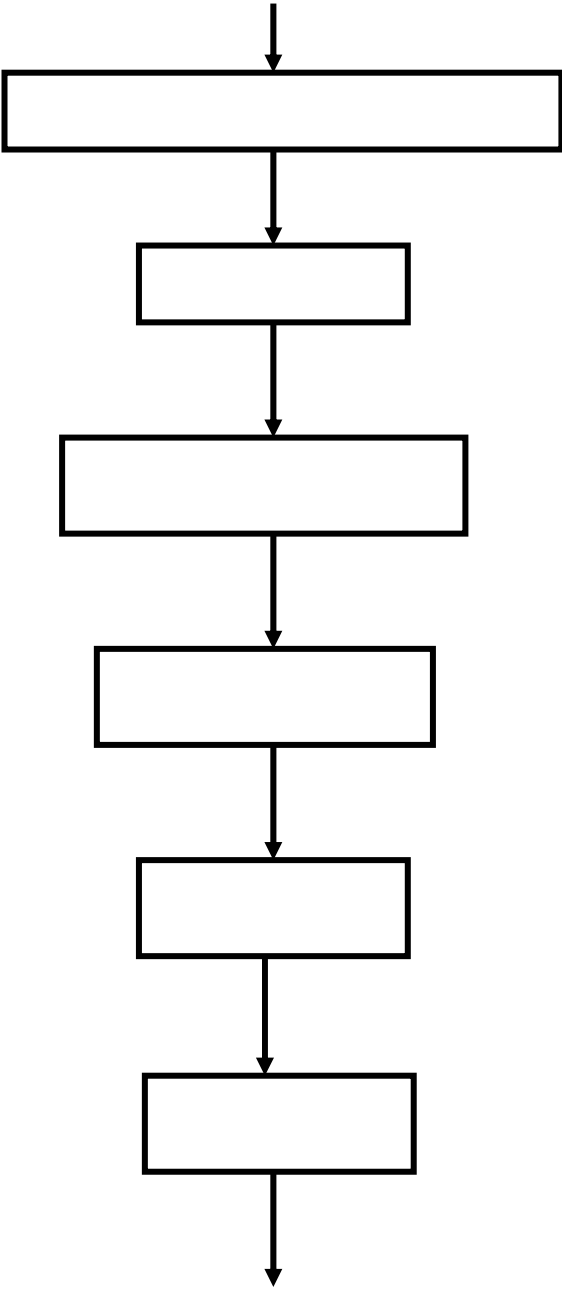

()

- -
-j

()

()

:

(xanthate)

()

		()					

() -

-							
						-	
		—					

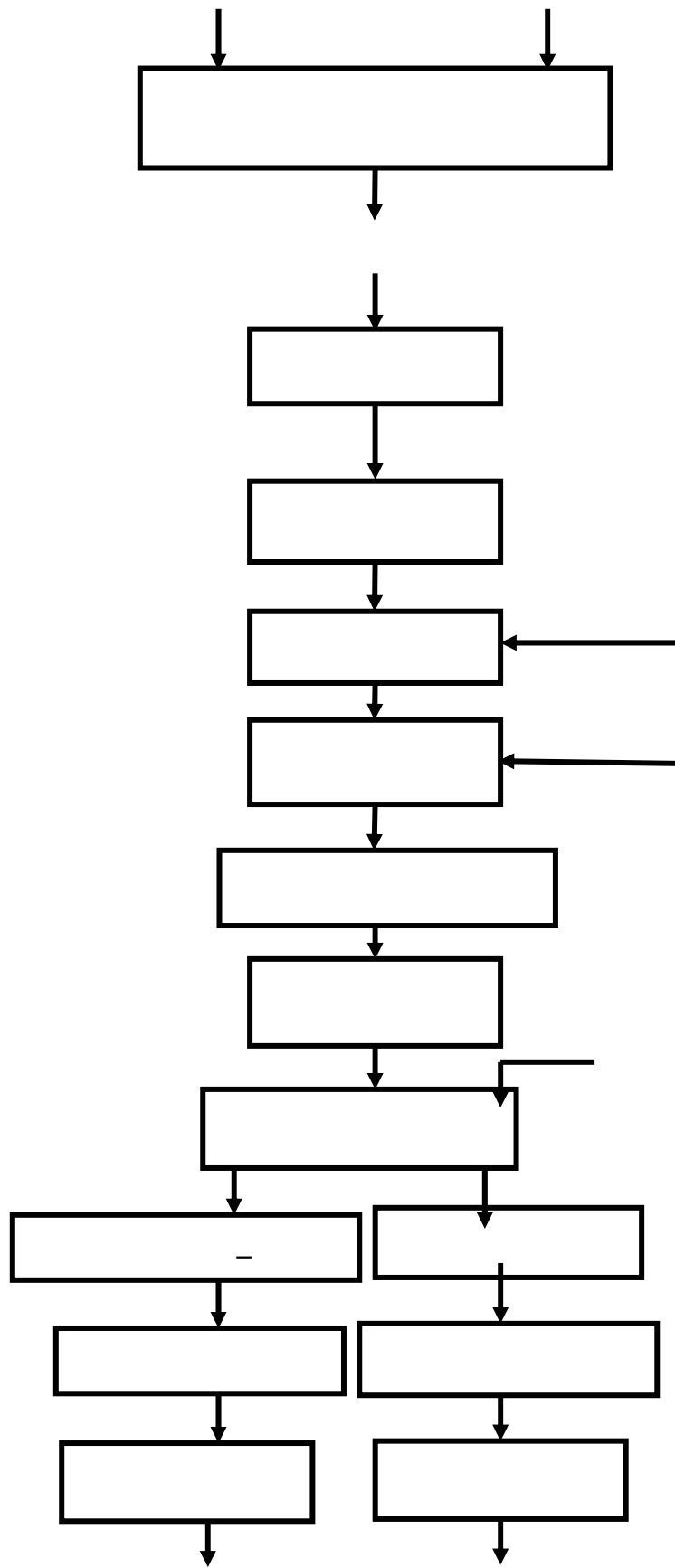

()

()

-

()

()

:

(caprolactum)

()

-							

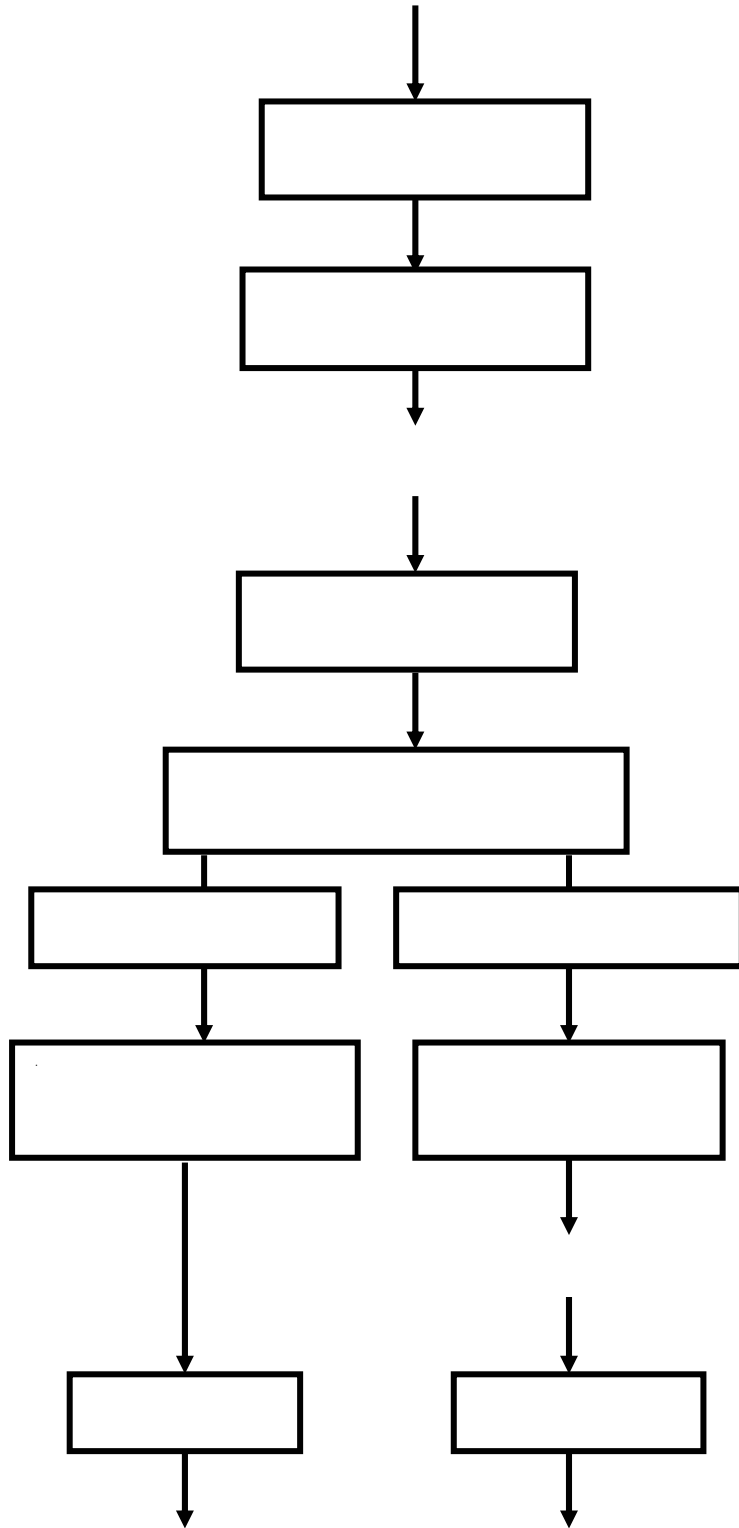

()

-

()

()

:

()

“POY”

()

	-)
	-						(
-							
					(POY)		
						(POY)	-
						(POY)	

(DMT)

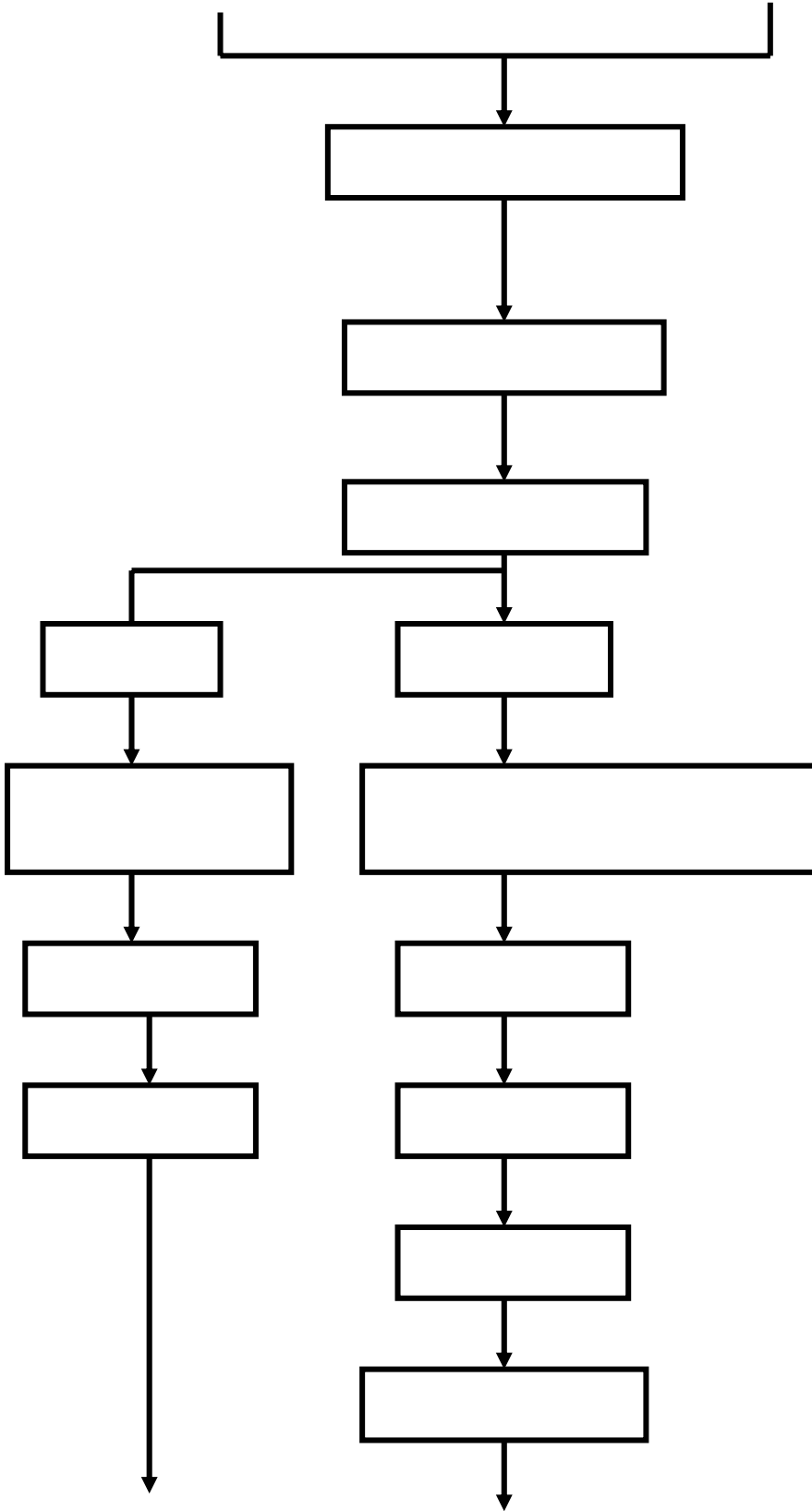

-

.
.
.

- -

:

)

□

(...

□

.
()

)

(

)

(

()

()

--

•

)

(

()

.(-)

•

"

"

•

--

--

:

(.....)

□

(.....)

□

□

--

:

.

.()

.

.

--

.

.

.

.

□

□

□

- -

.....

⋮

□

□

□

(scavenging system)

- -

· ···

·

(scavenging system)

·

· /

- -

()

-

(-)

- -

(···)

· ····

()

--

.

.

:

%

.

% -

.

.

.

% -

--

:

-

.(()

.

.

-

-

.

"

"

.

()

.

.



...

()

-

١-٤

/

.%

-

□

.

-

□

/

()

()

(/)		

()

/

(/)

()

	<hr/>					
	/		/			
	,		,			
					-	
	,		,			
	,		,			
+						
			,			
	,					

:

.

.

(residual chlorine)

()

.(

)

.

:()

:				:	/	:	/	(/)
				()			()	
					>					()
					>					
-	-	-	-	,	-	-				
					>					
					>					()
					>					
—	—		—		>	—				
					—					
—	—				>	—				

-

:

.

.

.

()

.

.

←-←

:

:

.()

:

()

.

:

()

:

() ()

.

□

□

□

5-4

)

(

6-4

Hyperlinkki http://es.epa.gov/oeca/sector/sectornote/pdf/textilsnp_.pdf

http://es.epa.gov/oeca/sector/sectornote/pdf/textilsnp_.pdf

Hyperlinkki http://es.epa.gov/oeca/sector/sectornote/pdf/textilsnp_.pdf

http://es.epa.gov/oeca/sector/sectornote/pdf/textilsnp_.pdf

Hyperlinkki http://es.epa.gov/oeca/sector/sectornote/pdf/textilsnp_.pdf

http://es.epa.gov/oeca/sector/sectornote/pdf/textilsnp_.pdf

Hyperlinkki http://www.u.se/IIIEE/publications/theses-/xir_abst.htm

http://www.u.se/IIIEE/publications/theses-/xir_abst.htm

)
(

(PVA)

.(CMC)

.%



-
--

□

□

--

--

()

--

•

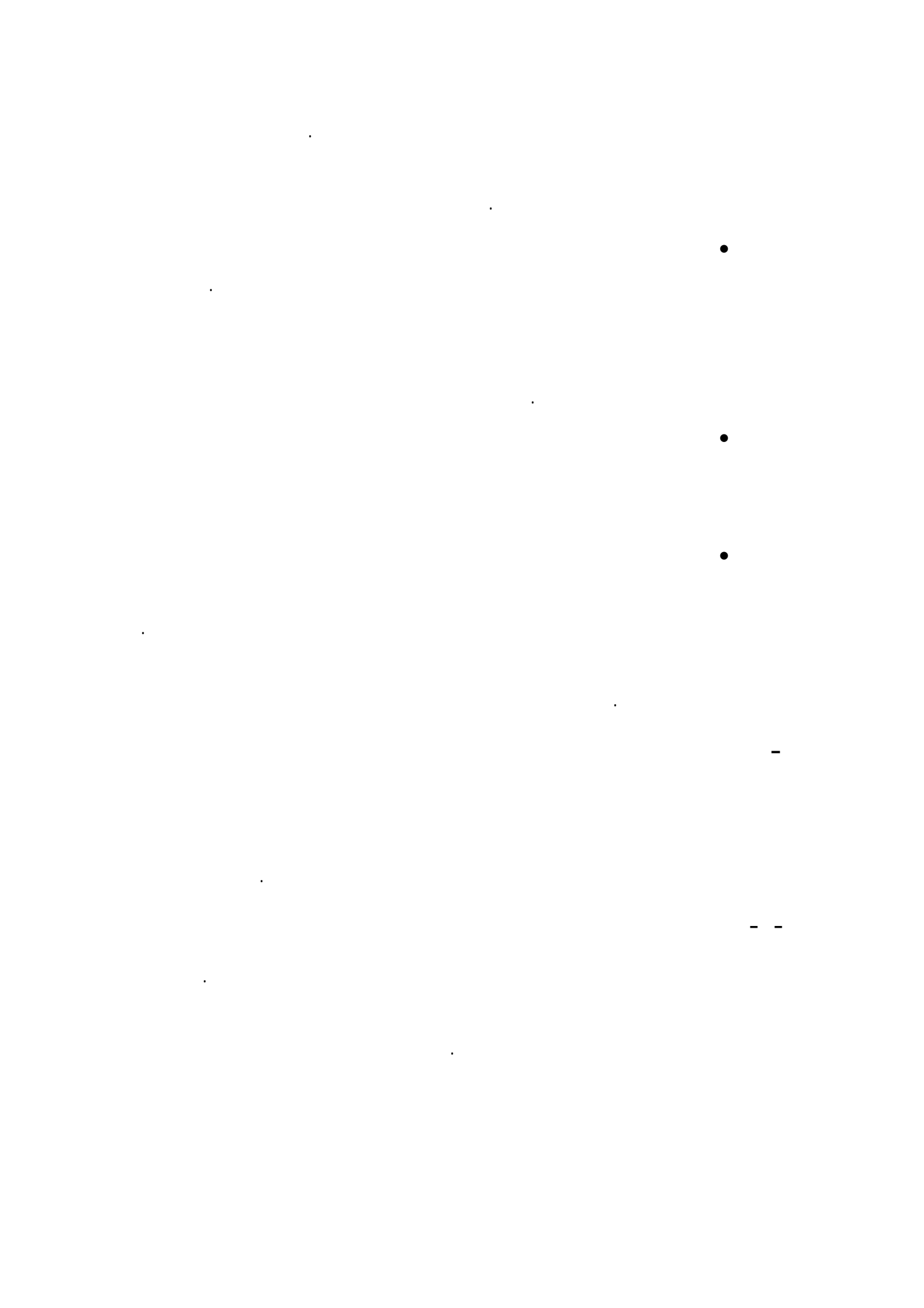

% -

.

)

.

(

.

(

)

%

.

.

.

.

.

--

•

•

•

•

•

•

)

(

•

•

•

•

•

:

- -

•

•

•

•

•

()

•

" "

" "

•

•

•

%

(%)

•

" "

•

•

- -

•

•

•

•

•

- -

)

(

) () (-

() () -

(VAT) -

()

)

(

()

(SIDA) (CPI)

(VAT)

(...

- -

:

□

.

□

.

/

.

:

.(FNT-)

-

-

-

-

-

-

-

-

-

-

-

-

-

-

-

- -

:

"

"

"

"

"

"

)

(

-

(MAC)

)

(

(

)

()



.

.

:

.

.

% -

. %

-

()

)

(

)

(

)

(

(DMT)



-

:

)

(

-

(SMS)

()

-

:

Trends

:

.

()

.

.

:

-

()

.

:

.

.

/

()

.

:()

.

:()

□

□

-

(EMS)

- -

:

ISO

()

:

-

aspects

-

/

:)

objective

target

.(

:)

.(

%

-

(internal auditing)

-

-

ISO

()

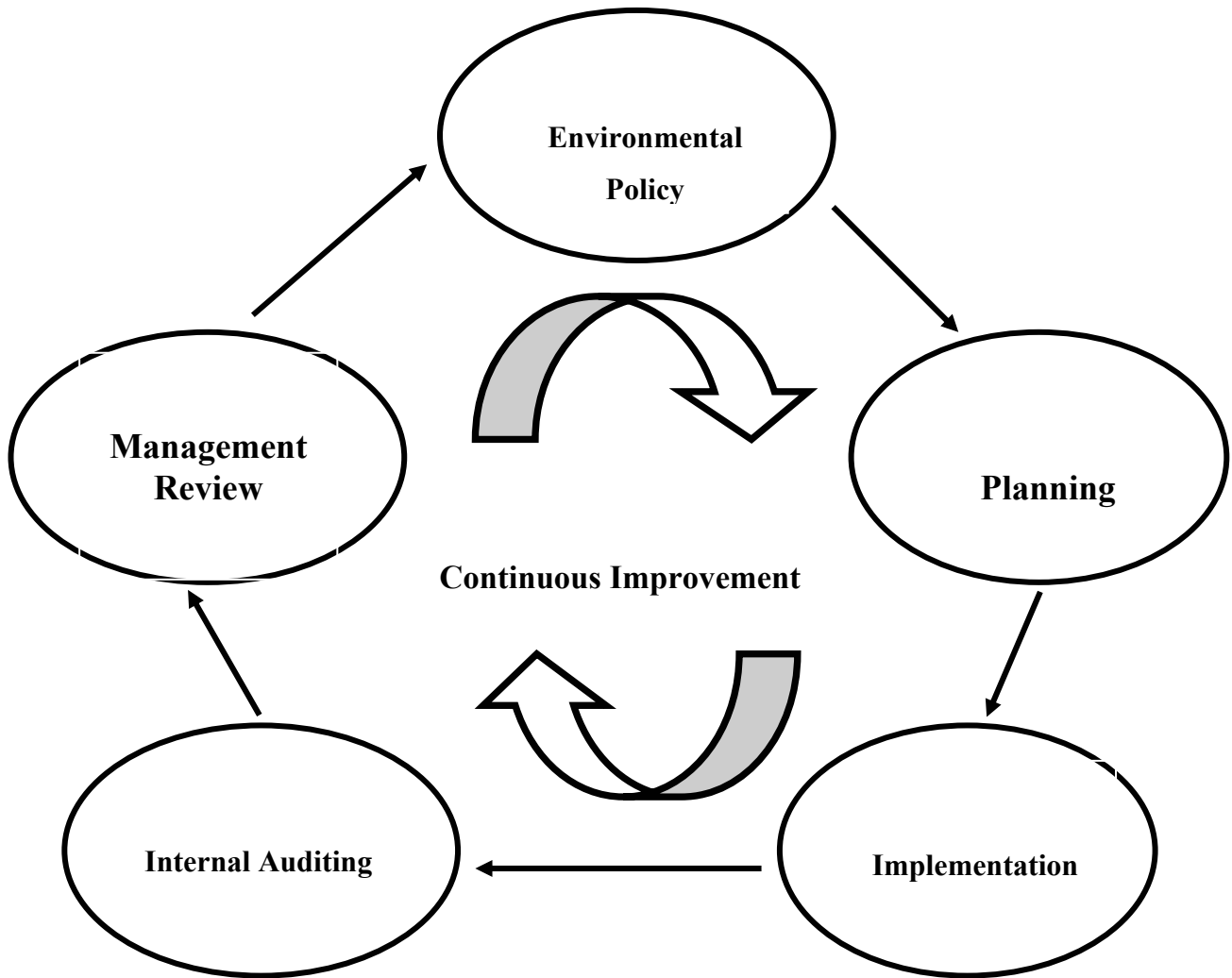

:(EMS)

(SM)

- -

:

ISO

(SMS)

"

"

:

:

(end-of-pipe)

)

(...

•

•

•

•

•

•

•

)

.(...

-
-
-
-
-

()

.SMS

EMS

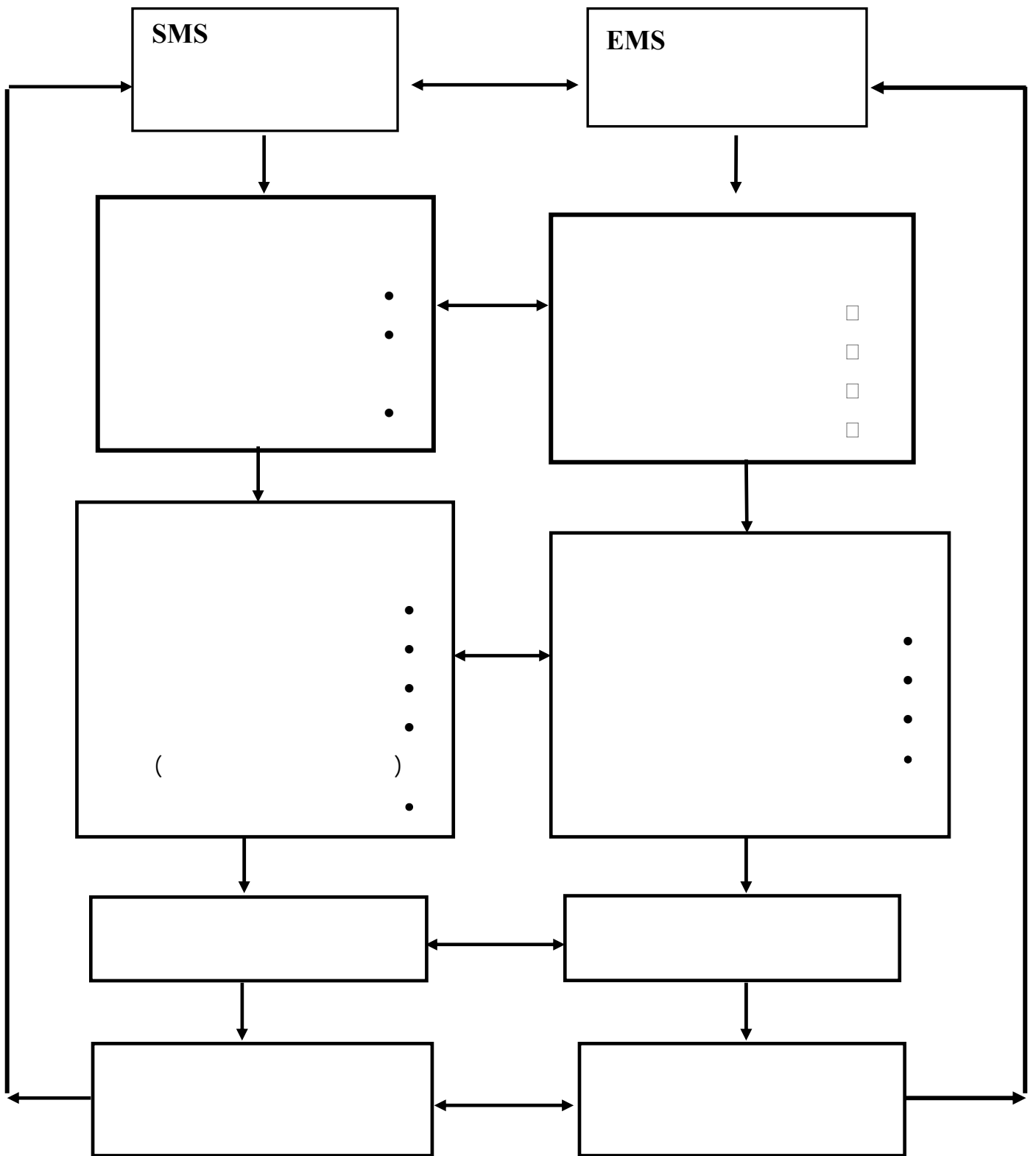

SMS

EMS

()

- -

.()

.(End-of-pipe)

(Cost -benefit analysis)

-

- -

()

:

--

(QA/QC)

:

()

:

-
-
-
-

()

-

()

:

-
-
-
-
-
-
-
-

.QC/QA

:

"

"

"

"

"

"

()

-

:

:

•

:

•

:

•

:

•

()

()

			(BOD) (COD)		

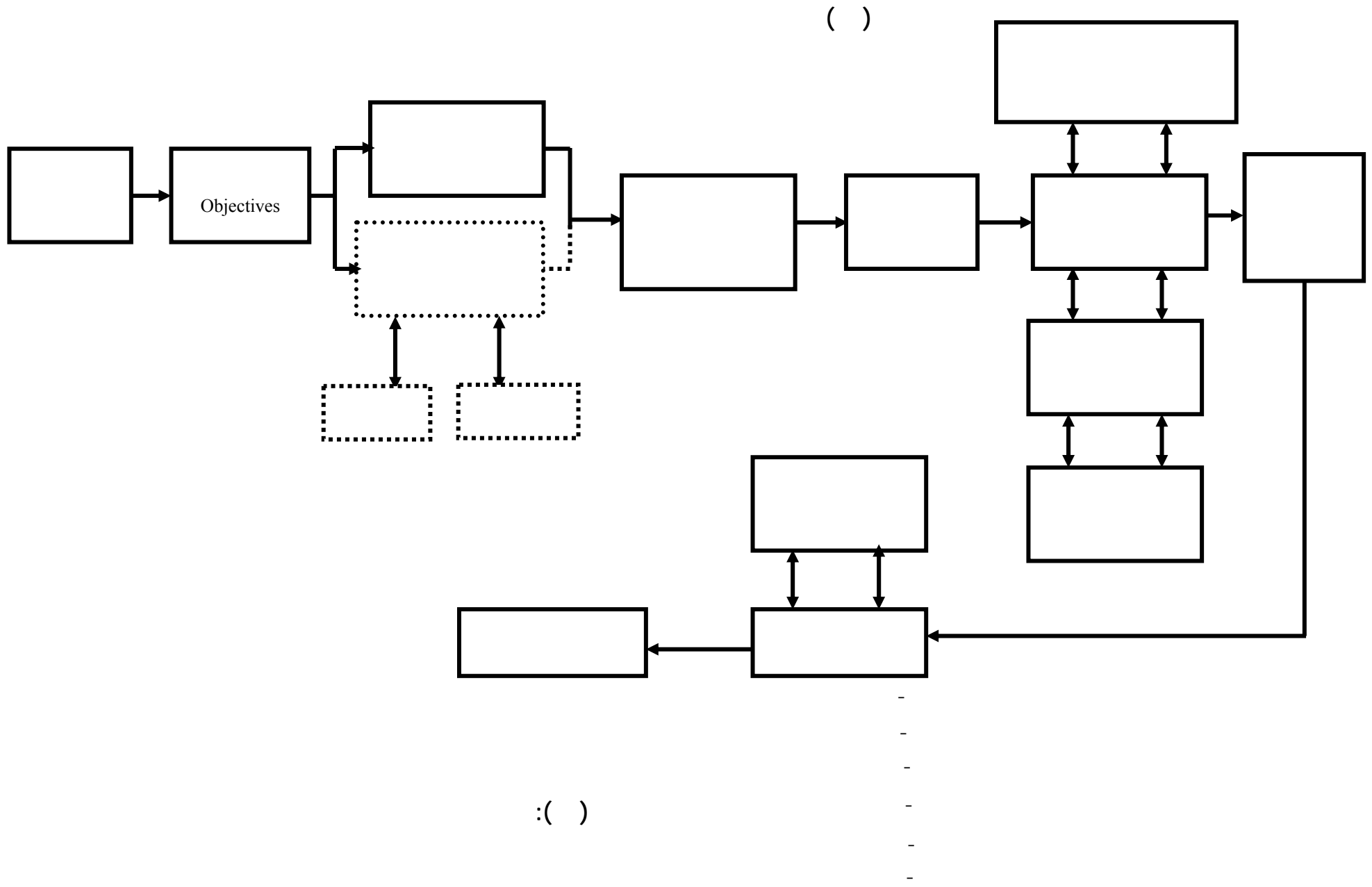

-

:(EPAP)

-
-
-

trends

-

:

:

-
-

:

()

:

-

:

-

:

:

•

•

•

•

-

:

trends

•

()

•

•

time-averaged means

.frequency distribution

daily mean value

/)

.(

:

-
-
-
-

-

:

/

:

/

:

-
- .Mass balance
- .Emission Factors
-

--

(

/

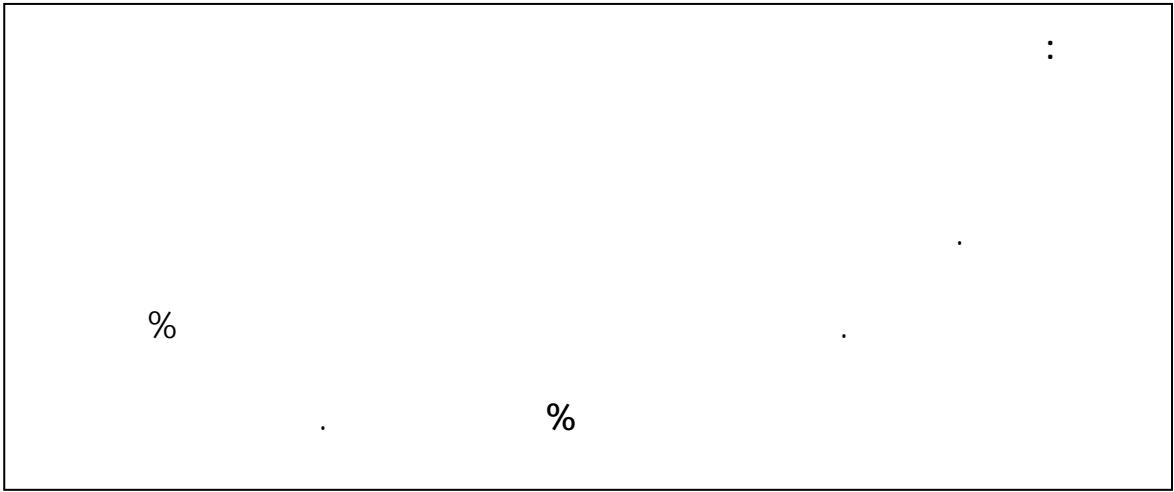

%

%

:

•

•

corrosive)

.(substances

(

)

•

:)

•

.(

	<p style="text-align: right;">•</p> <p style="text-align: right;">.(dioxin)</p> <p style="text-align: right;">•</p> <p style="text-align: right;">•</p>

Mass balance () - -

$$+ = +$$

: ()

.()

.()

:

Emission factors

- -

)

.(

.(

) DSS :

:

- -

/

(

:

)

-

-

COD () BOD)
() .(...)

()

Indication		
) ()
		()
- - ()		

-

()

:()

Indication		
	-	-
	-	-
.		:
		:
		:
		:

-

()

()

Indication		
		:(/)) -(
	()	:() () -

-

.

.

.

.

-

()

.

()

/						
			- /			
						()
	- -		VOCs - -	- : ,BOD,COD		Scouring
				:	PVA	(Sizing)

/						
				,BOD, COD		
				-	- -	
				BOD,) :		
				,COD (Carbonizing

() -

/						
				: ,BOD, pH: -		Scouring
		pH		: pH:		Bleaching
				pH:		Mercerising

/						
				VOCs : - : - COD		Dyeing
				VOCs : COD : 		Printing
				VOCs : COD : BOD		Finishing

/						
			.	-	, CO, CO2, NOx, SOx, BOD	
	-		VOCs	-	VOCs	
()						
	- -					

-

()

()

:

•

•

•

-

-

-

•

:()

:

-

-

-

∴
-
-
-
-
-
-
-

()

/		

-

()

Cl, CO , CO, SO , NO_x :

.CO

TRS, SO_x :

()

-

/ :

:

:

/ (Q)

•

/ (TSS)

•

(C)

•

. /O (COD_{Cr})

•

. /O (BOD)

•

/ (N)

•

•

mS/m

•

.()

Venturi

(grab sample)

TSS,COD

BOD



(BOD, COD)

(-)

/								
								-
								-
								-
								-
						(Elutriator) -		
								-
								-
								-
								-

(-) -

/							
						-	
						-	
						-	
						-	
						-	
						-	
						-	
						-	

(-) -

/							
						-	
						-	
						-	
						-	
						-	:

(-)

/								
								- (BOD COD) - - -
								- -
								% (BOD) - - - - -

/									
							(pH) (BOD)		
							-	-	
							-	-	

/								
							-	-
						-	-	-

-

.

.

.

.

.

.

•

•

•

•

.

.

.

QA/QC

.()

()

:

-
-
-
-

()

+

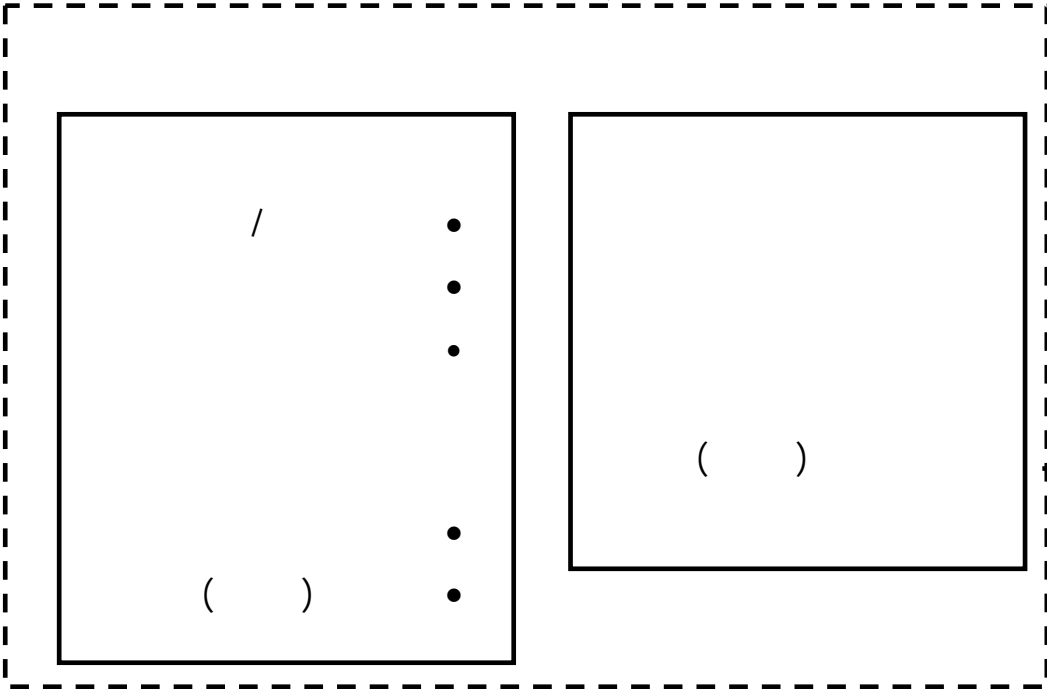

- -

: - -

:

-
-
-
-
-

/

:)

.(

- -

EPAP

/

.()

/

()

- -

:

•

•

--

--

--

()

:

Reliability

-

:

()

:

± /

%

/

:

. :
.)
. (

Comparability : -

Data Production Chain : -

. :
. /
. : /

/

:

:

pH

:

:

:

/

-
-
-
-

-
-
-

:

()

:

:

:(/)

:(/)

:(%O ppm /):

:(/)

:() Residence time

:(C)

:

Certification

.Certification and Accreditation

()

/

-1

-2

-3

-4

-5

-6

-7

(/ / /)

- /

- /

- /

- /

-8

()

- /

•

•

•

- /

•

•

•

.(/ /)

.(/ /)

-9

-10

/

. / (/) / / /

. /

:

*

-
*
-
*
-

-
*

-
:
-

:

: -

. : .

: - : *

()

-

-

-

-

(/)

-

(/)

-

...

)

.(

-

.()

-

. .

-

:

-

. ()

.

-

:

(/ /)

-
-
-
-

-

-

-

-

()

- -

-

()

•
•

--

()

•
•

)

--

.(

--

•
•
•
•

-

--

mg/l
m /d
kg/d

•
•
•

--

•
•

-
-
-
-

-
-

- -

)

(

-

- -

-
-
-

- -

-
-

-

- -

-
-

- -

-
-
-

-

- -

- -

()

-

-

-

-

-

-

-

()

- " - "

- .

- *“Monitoring and Control Practices of Emissions in Pulp and Paper Industry in Finland”*, , Saarinen K., Jouttijarvi T. and Forsius K., Saarinen K., Finnish Environment Institute

- *“Data Production Chain in Monitoring of Emissions”*, , Saarinen K, Finnish Environment Institute.