

mitsubishi

Mr.SLIM

Changes for the Better

Issued in 2003

Construction Manual for Power-Inverter Air Conditioner

For R410A

Mr.SLIM

Contents

1. Difference between Refrigerant R22 and Alternative Refrigerant R410A.....	4
2. Difference in Material of Refrigerant Pipe between R22 and R410A	5
3. Installation Procedures and Cautions on Construction	6
4. Airtight Test	7
5. Vacuuming (Vacuum Drying).....	8
6. Checking the Gas Leakage.....	10
7. Reusing the Existing Pipe	11
8. Tools for Installation	15
9. Tools for Refrigerant Charge	16
10. Checking the Operation Condition	17
11. Capacity correction	18
12. Field electrical wiring (Power wiring specification)	19
13. Check List for Existing Pipe Work	20

◆ Interpretations of model name

< Indoor unit >

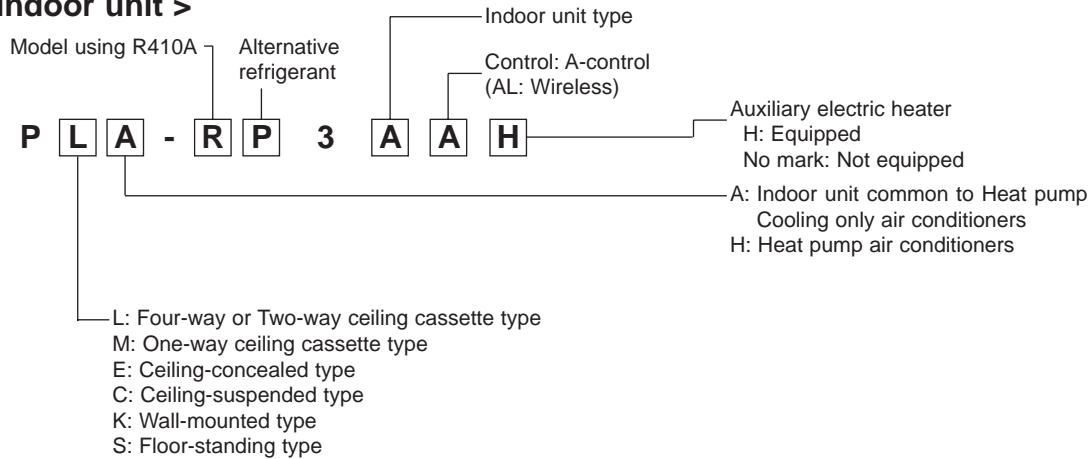

< Outdoor unit >

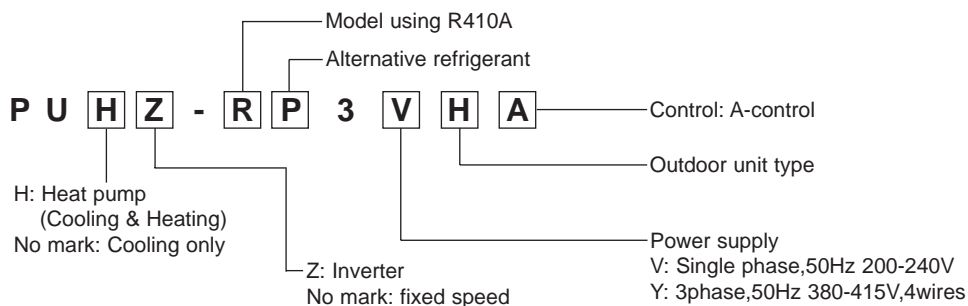

◆ Notes for construction of air conditioner using alternative refrigerant R410A

- (1) The judgment whether the existing pipe can be used or not should be made same as the models using R407C.
 - Basically, the existing pipe needs to be washed except for a certain condition mentioned in the separate catalog. (See "Conditions which make it possible to use the existing pipe without washing" mentioned in the notes on page 11.)
 - When removing the existing unit, be sure to perform pump down to recover refrigerant and refrigerant oil.
 - If the pipe is $\phi 12.7$ or less, make sure its wall thickness is 0.8mm.
 - If the inside of the pipe is extremely dirty, wash it in the same way as the pipe of the unit using R22 or replace the pipe with new one.
 - Since the refrigerant oil depends on the capacity class of units, be sure to perform construction appropriately according to the refrigerant oil used.
- (2) The existing flare tool can be used, however, see page 15 for the part of pipe protruded from the dice.
- (3) The torque wrench for tightening the flare nut is same as the one for our packaged air conditioner using R407C
- (4) The diameter of connecting mouth of service port corresponds to the use of R410A.
- (5) Three principles of refrigerant pipe
 - Basic piping work is same as the one for the unit using R22. However, attention needs to be paid since the refrigerant must be recovered and charged again if the refrigerant leaks or if any foreign material goes into the pipe and this results in a malfunction of unit.
 - ①Dryness No moisture must remain in the pipe.
 - ②Cleanliness No dust must remain in the pipe.
 - ③Tightness No refrigerant must leak.
- (6) Perform brazing work by replacing the air in the pipe with nitrogen (Blowing of nitrogen into the pipe).
 - If brazing is performed without blowing nitrogen into the pipe, a great deal of oxide skin will generate in the pipe. This oxide skin could result in a malfunction of unit since it would clog the solenoid valve, the capillary tube, the oilcollecting hole of power receiver, or the inlet of oil pump in the compressor.
- (7) Use the tools exclusive for R410A.

1. Difference between Refrigerant R22 and Alternative Refrigerant R410A

1.1 Chemical characteristics of refrigerant

Alternative refrigerant R410A, which has similar characteristics to R22, is less toxic, nonflammable and chemically stable. However, since the vapor density of alternative refrigerant is higher than the air density, if the refrigerant leaks in the closed room, it stays around the lower area of the room and could result in oxygen deficiency. Moreover, if the refrigerant comes into contact with fire directly, toxic gas will be generated. Therefore, it is very important to use the refrigerant under the environment that lets a lot of air pass through and that prevents the refrigerant from staying in the room.

Name	Refrigerant (HCFC)		Alternative refrigerant (HFC)	
	R22	R407C	R410A	
Component	HCFC22	HFC32/HFC125/HFC134a	HFC32/HFC125	
Composition (%)	100	23/25/52	50/50	
Type of refrigerant	Single refrigerant	Non-azeotropic refrigerant mixture	Near azeotropic refrigerant mixture	
Chlorine	Contained	Not contained	Not contained	
Safety class	A1	A1/A1	A1/A1	
Molecular weight	86.5	86.2	72.6	
Boiling point [°C]	-40.8	-43.6	-51.4	
Steam pressure (at 25°C) [MPa (gauge)]	0.94	0.9177	1.557	
Saturated vapor density (at 25°C) [kg/m³]	44.4	42.5	64.0	
Ozone depletion potential (ODP) *1	0.055	0	0	
Global warming potential (GWP) *2	1700	1530	1730	
Refrigerant charging method	Gas charge	Refrigerant is taken out from the liquid phase of gas cylinder.	Refrigerant is taken out from the liquid phase of gas cylinder.	
Additional charge due to refrigerant leakage	Possible	Possible temporarily	Possible	

*1 Based on CFC11 *2 Based on CO₂

1.2 Composition change and cautions on handling of refrigerant

It is possible to charge additional refrigerant if the refrigerant leaks.

Since R410A is a near azeotropic refrigerant mixture composed of HFC32 and HFC125, it can be handled almost like a single refrigerant R22. As for refrigerant charge, however, if the refrigerant is taken out from the gas phase, the composition inside the gas cylinder will slightly change. Therefore, take out the refrigerant from the liquid phase of gas cylinder.

Relation between the composition and the refrigerant amount left in the gas cylinder when the refrigerant is taken out from the liquid phase or the gas phase

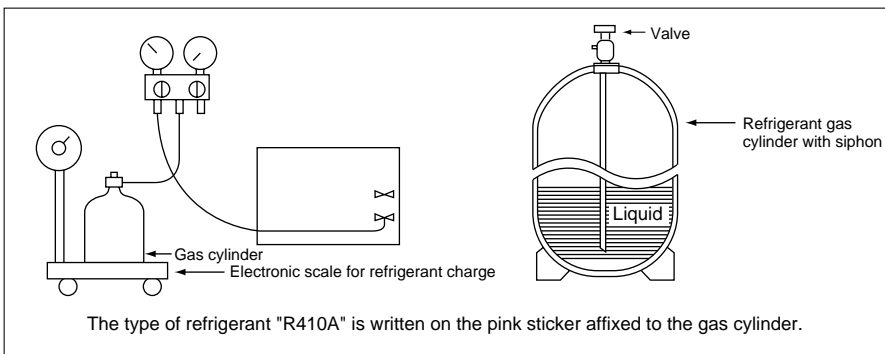
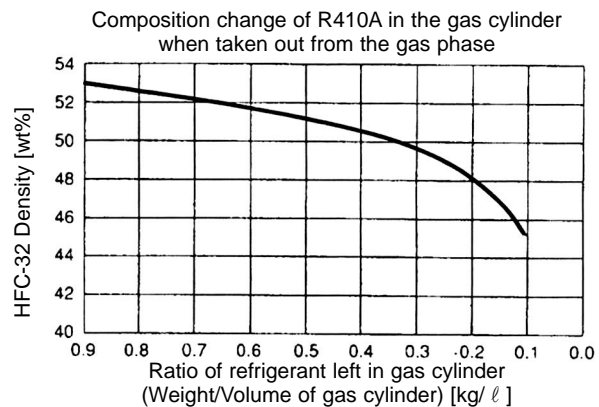
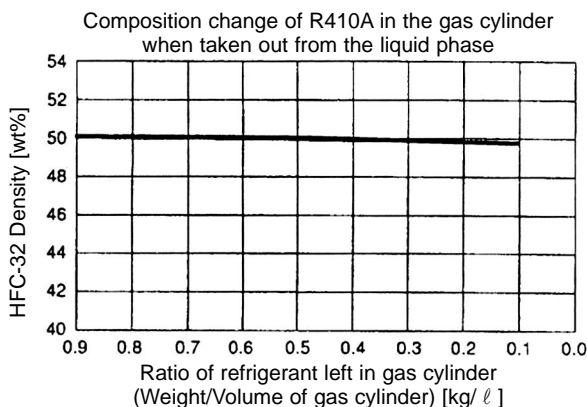

When the refrigerant is taken out from the gas phase, the composition change of refrigerant in the gas cylinder is greater than the case where the refrigerant is taken out from the liquid phase. Therefore, charge the refrigerant by taking it out from the liquid phase of gas cylinder. Since the gas cylinder for R410A is equipped with siphon, the refrigerant can be taken out from the liquid phase without turning the gas cylinder upside down.

2. Difference in Material of Refrigerant Pipe between R22 and R410A

New refrigerant R410A is adopted for power inverter series. Although the refrigerant piping work for R410A is same as for R22, exclusive tools are necessary so as not to mix with different kind of refrigerant. Furthermore as the working pressure of R410A is 1.6 time higher than that of R22, their sizes of flared section and flare nuts are different.

2.1 Required wall thickness of refrigerant pipe when using R410A

The outside diameter of pipe is same as the one for the unit using R22, however, the working pressure of R410A is higher. Therefore, check the wall thickness of pipe before use. (It is impossible to use the pipe, whose wall thickness is thin [$\phi 6.35 - t0.7$].)

Pipe diameter and Wall thickness

Nominal diameter	Outside diameter [mm]	Min Wall thickness [mm]	RP1.6,2	RP2.5,3,4,5,6
1/4"	6.35	0.8	Liquid pipe	
3/8"	9.52	0.8		Liquid pipe
1/2"	12.7	0.8	Gas pipe	
5/8"	15.88	1.0		Gas pipe

2.2 Dimensions of flare nut and flared part of copper pipe

Since the constituent element of HFC refrigerant is smaller than that of R22 and the pressure of R410A is higher than that of other refrigerants, R410A seems to leak at high risk.

Therefore, the standard for dimension of flared part of copper pipe for R410A is different from the one for other refrigerant as follows to increase air tightness and strength. The standard for dimension of opposite side of flare nut for R410A has also been revised partly to increase strength as follows.

When flaring the copper pipe, set the part of pipe protruded from the dice correctly and follow the tables below.

See "Flare tool for R410A" on page 15 for details. When the nominal diameter is 1/2" or 5/8", the dimension of opposite side (Dimension "B") is different between R22 and R410A and the torque wrench for R410A refrigerant is needed.

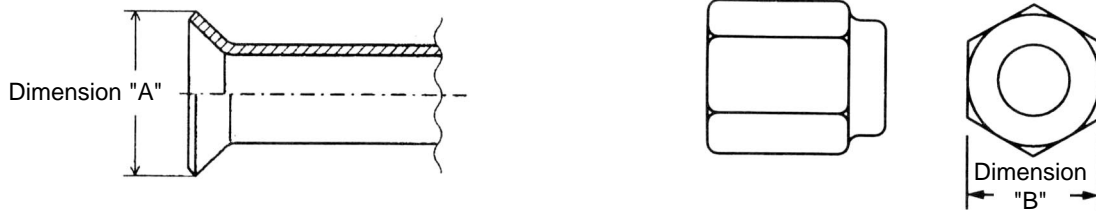

Nominal diameter	Outside diameter [mm]	Dimension "A" ($+0_{-0.4}$)	
		R22	R410A
1/4"	6.35	9.0	9.1
3/8"	9.52	13.0	13.2
1/2"	12.7	16.2	16.6
5/8"	15.88	19.4	19.7
3/4"	19.05	23.3	—

Nominal diameter	Outside diameter [mm]	Dimension "B"	
		R22	R410A
1/4"	6.35	17	17
3/8"	9.52	22	22
1/2"	12.7	24	26
5/8"	15.88	27	29*
3/4"	19.05	36	—

※:36.0mm for indoor unit of RP4,5 and 6.

3. Installation Procedures and Cautions on Construction

	Changes and cautions about construction procedures of unit using alternative refrigerant.	Reasons	Ref. page
Checking the refrigerant used	Check and grasp the characteristics of refrigerant used, and be sure to charge the specified refrigerant if the refrigerant needs to be charged.	※If the refrigerant other than the specified one is used, the unit could malfunction.	4
Making the construction drawing			
Checking the construction place			
Preparation before construction	<ol style="list-style-type: none"> Use the refrigerant pipe whose wall thickness is specified in the page 5. Prepare the following tools exclusive for R410A beforehand. (For installation) Gauge manifold ·Flare tool ·Charge hose ·Vacuum pump ·Backflow prevention device (for vacuum pump) (For refrigerant charge) ·Electronic scale for refrigerant charge ·Refrigerant gas cylinder ·Charge mouth for refrigerant gas cylinder 	※Required withstand pressure can be secured. ※The size of screw for service port is changed from 7/16 UNF to 1/2 UNF. ※The materials suitable for HFC refrigerant are used. ※Wrong use of R22 is avoided. ※If the oil in the vacuum pump flows backward into the unit, the unit could malfunction.	5 8 9 10 16 17
Inserting the sleeves			
Installing the indoor unit			
Refrigerant pipe work	Observe the followings to keep the inside of pipe clean and airtight. <ol style="list-style-type: none"> Use the pipe whose inside is clean. Do not let any foreign material go into the pipe when leaving the pipe unconnected. Flare the pipe closely. Apply the specified oil to the flared part of pipe. (Ester oil, ethereal oil and alkyl benzene oil, etc.) Check the dimension of opposite side and shape of flare nut. Use the torque wrench to tighten the pipe securely. Blow nitrogen into the pipe when brazing is performed. Before connecting the pipe to the unit, discharge the air in the pipe from the pipe connections. 	※If there is foreign material or moisture in the pipe, the cooling effect could be insufficient or the compressor could malfunction. ※If the refrigerant leaks, the unit could stop due to abnormality or the unit's capacity could be insufficient.	5 11 12 13 14
Drain pipe work			
Duct work			
Heat insulation work			
Electrical work			
Installing the outdoor unit			
Connecting the refrigerant pipe	<ol style="list-style-type: none"> Apply the specified oil to the flared part of pipe. (Ester oil, ethereal oil and alkyl benzene oil, etc.) Use the torque wrench to tighten the pipe securely. 	※If the refrigerant leaks, the unit could stop due to abnormality or the unit's capacity could be insufficient.	16
Airtight test	<ol style="list-style-type: none"> Use nitrogen gas to raise the pressure to the designed pressure of unit, and perform the airtight test for 24 hours. 	※If the refrigerant leaks, the unit could stop due to abnormality or the unit's capacity could be insufficient.	7
Vacuuming	<ol style="list-style-type: none"> Use the vacuum pump equipped with a backflow prevention function or use the conventional vacuum pump together with a backflow prevention device. Perform vacuuming fully (for about 1 hour or more after the low pressure has reached -0.1Mpa.). Do not use any refrigerant to purge air. 	※If the oil in the vacuum pump flows backward into the unit, the unit could malfunction. ※Removing moisture and air fully prevents oil deterioration.	8 9
Charging the additional refrigerant	<ol style="list-style-type: none"> Take out R410A from the liquid phase of gas cylinder. (If the gas cylinder with siphon is used, turning it upside down is not necessary.) Use the gauge manifold and charge hose exclusive for R410A. 	※If R410A is taken out from the gas phase, the composition of refrigerant charged changes, and the unit could stop easily due to abnormality or the unit's capacity could be insufficient easily. ※Wrong charge of refrigerant is avoided.	4 17
Checking the gas leakage	Use the refrigerant leak detector for alternative refrigerant.	※The conventional refrigerant leak detector cannot detect R410A.	10 17
Test run			
Explanation of completion of installation and operation method to customers	For units equipped with the replacement filter (RP4,RP5,RP6), perform pipe washing operation in the cooling mode for about 2 hours.	※The replacement filter recovers chemical compound containing chlorine remained in the pipe.	14

4. Airtight Test

After finishing the refrigerant pipe work, check if the gas leaks from the pipe connected in the field.

4.1 Purpose

Make sure no refrigerant leaks from the pipe between the indoor unit and the outdoor unit, connected in the field.

4.2 When the refrigerant leaks

The refrigerant oil could deteriorate, the unit's capacity could decrease, and the unit could malfunction.

4.3 Testing procedures

Airtight test method for refrigerant pipe.

·Apply pressure to either liquid pipe or gas pipe.

Photo 1



⚠ Caution

1. Perform the airtight test with the stop valve and ball valve of outdoor unit closed. <See Photo 1.>
2. Do not use chlorine refrigerant, oxygen or flammable gas as pressurized gas.
(The use of oxygen could result in an explosion.)

4.3 Connection

- Connect the testing tools, referring to the illustration on the right.
- Connect them to the service port of stop valve on either liquid pipe side or gas pipe side.

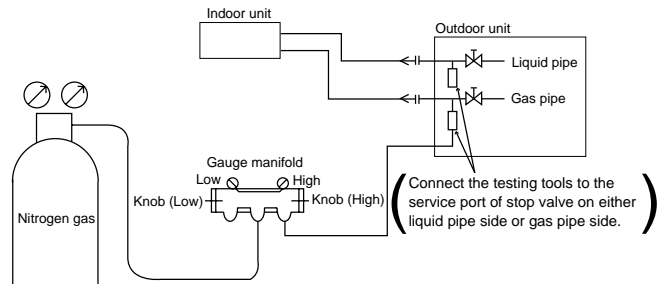

Apply pressure to the outdoor unit gradually. Do not raise it to the specified pressure at a stretch.

	Procedures	Pressurization and waiting time
①	Apply pressure of 0.5MPa (5kgf/cm ²) to the outdoor unit and wait for 5 minutes. After that, make sure the pressure does not decrease.	①0.5MPa
②	Raise the pressure from 0.5MPa to 1.5MPa (15kgf/cm ²) to apply it to the outdoor unit and wait for 5 minutes. After that, make sure the pressure does not decrease.	5 min. ②1.5MPa
③	Raise the pressure from 1.5MPa to 4.15MPa (42.3kgf/cm ²) to apply it to the outdoor unit and record the ambient temperature and the pressure.	5 min. ③4.15MPa
		24 hours

- Remove the nitrogen gas cylinder and wait for 1 day (24 hours). After that, make sure the pressure does not decrease.
- After removing the gas cylinder, be sure to put a stopper on the part where the cylinder was connected to prevent refrigerant leakage.

Example when the nitrogen gas cylinder is removed

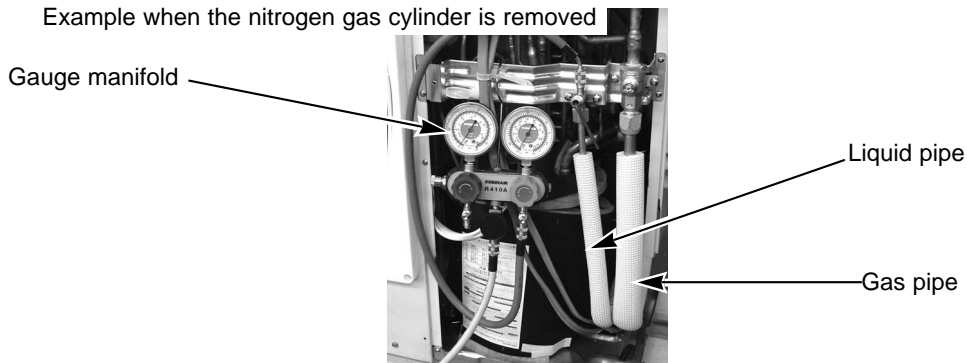

- If the specified pressure holds for about 1 day and does not decrease, the refrigerant pipe have passed the airtight test.
- If the ambient temperature changes by 1 , the pressure changes by about 0.03MPa (0.3kgf/cm²).

Therefore, correction is needed.

$$\text{Correction value} = (\text{Temperature in 24 hours} - \text{Temperature when the pressure is raised to 4.15MPa}) \times 0.03$$

There is refrigerant leakage if the pressure decreases on the steps ① to ③. Repair the part where the refrigerant leaks.

5. Vacuuming (Vacuum Drying)

5.1 Purpose

- Discharge the air in the pipe or nitrogen when the airtight test is performed.
- Perform vacuum drying for the inside of pipe.

5.2 When vacuuming is not performed fully

- ① If air goes into the pipe, the high pressure rises abnormally and the compressor could malfunction.
 - ② If a slight amount of moisture (moisture in the air) goes into the refrigerant cycle, the unit could malfunction.
 - ③ If moisture remains in the refrigerant, the expansion valve could freeze and the unit could malfunction.
- When the atmospheric pressure in the pipe is brought close to a vacuum by the vacuum pump, the boiling point of water in the pipe lowers.

Lowering the boiling point of water than the outside temperature evaporates water and discharges it outside.

Relation between water evaporation temperature and vacuum degree

Evaporation temperature	100°C	90°C	80°C	70°C	60°C	50°C	40°C	30°C	20°C	10°C	0°C	-17°C	-68°C
Vacuum degree torr (mmHg)	760	525	355	234	149	90	55	36	17	9	4.6	1	0.003
Absolute pressure MPa (abs) (Atmospheric pressure)	0.1013	0.070	0.047	0.031	0.022	0.012	0.0073	0.0048	0.0027	0.0012	0.0006	0.00013	3.9×10^{-7}

⚠ Caution

1. If the oil in the vacuum pump flows backward into the refrigerant cycle, this could be a major cause of damage to the unit. Therefore, use the vacuum pump together with a backflow prevention device to prevent the oil in the vacuum pump from flowing backward.
2. Since the refrigerant oil used in the HFC refrigerant cycle is highly hygroscopic to moisture, it will generate acidic material even if a slight amount of moisture gets mixed into it. Therefore, remove moisture fully by the vacuum pump (0.5 Torr or less) that provides a high vacuum.

5.3 When there is no need to charge additional refrigerant

Perform vacuuming for the extension pipe and the pipes of the indoor unit.

5.4 Connection

- Connect the apparatus, referring to the illustration below (initial state).
(Close the stop valve and ball valve of outdoor unit.)

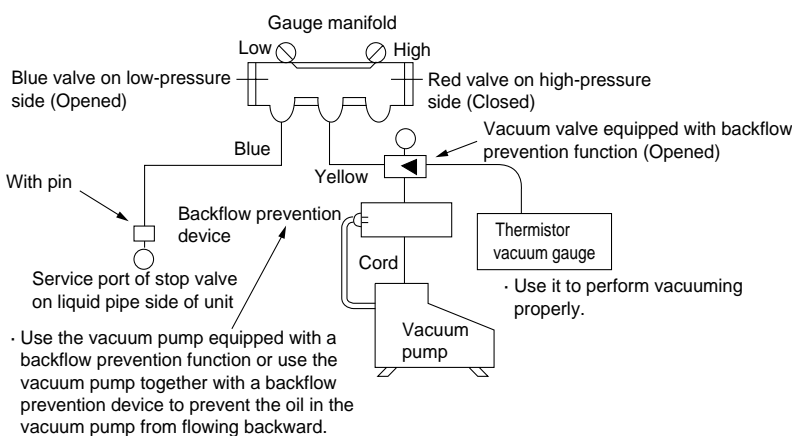

· If the oil flows backward from the unit or the vacuum pump, the thermistor vacuum gauge could be damaged. Therefore, use the vacuum valve to prevent the oil from flowing backward.

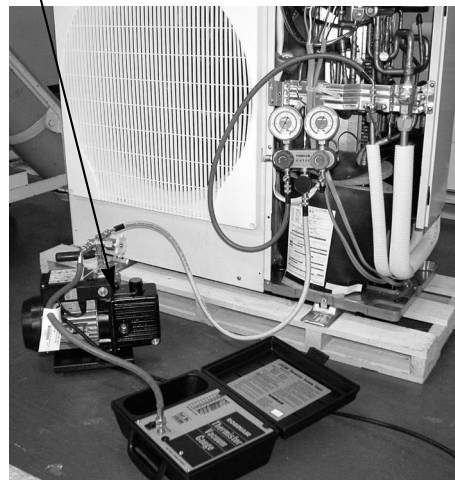

Note 1) A vacuum gauge can be used as an alternative for thermistor vacuum gauge.

If the vacuum gauge is used, be sure to use the vacuum valve to prevent the pressure of refrigerant from being applied to the vacuum gauge and to prevent the oil from flowing backward. After completion of vacuuming, close the valves at the inlet/outlet of vacuum gauge.

5.5 Procedures

Gauge manifold valve structure and operating procedures

Valve (Low) on low-pressure side Valve (High) on high-pressure side
(Opened) (Closed)

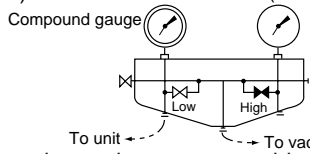

(Initial state)

- Open the blue valve on low-pressure side and close the red valve on high-pressure side of gauge manifold valve.
- Open the vacuum valve.
- Connect the power supply for vacuum pump to the backflow prevention device. (The current of vacuum pump must not be over the allowable current of backflow prevention device.)



1. Set the switches of vacuum pump and backflow prevention device to ON and start vacuuming.
- Set the switch of thermistor vacuum gauge to ON.



2. Measure the low pressure by the compound gauge and when it has reached -0.1MPa , perform vacuuming for about 1 hour. (Measure the vacuum degree by the compound gauge in 1 hour and make sure it is 1000 micron [1 Torr] or less.)

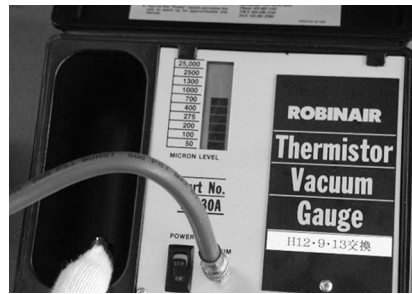

3. After completion of vacuuming, close the vacuum valve and set the switches of vacuum pump and backflow prevention device to OFF. Wait for 1 or 2 minutes and make sure the pressure does not increase by observing the scales of gauge manifold and thermistor vacuum gauge. (If the pressure increases, this shows that there is refrigerant leakage. Check the part where the refrigerant leaks by the airtight test and carry out repairs. Then, perform vacuuming again.) After that, set the switch of thermistor vacuum gauge to OFF.



4. After completion of vacuuming, make sure there is no refrigerant leakage, close the blue valve on low-pressure side of gauge manifold and slightly open the ball valve on gas pipe side. When the pressure gauge (compound gauge) of blue valve on low-pressure side of gauge manifold reads $0.1\text{-}0.2\text{MPa}$ or more, remove the blue charge hose immediately. (This prevents air from going into the refrigerant pipe.)

5. Fully open the ball valve on gas pipe side and the stop valve on liquid pipe side.



©Now, the vacuum drying has been finished when there is no need to charge additional refrigerant.

6. Checking the Gas Leakage

6.1 Purpose

It is important to pay attention to gas leakage since R410A has smaller constituent element and higher pressure compared to the conventional refrigerant.

6.2 Tools

Alternative refrigerant needs 25-40 times the detection capability of the conventional refrigerant leak detector for R22. Even if the detection sensitivity of the conventional refrigerant leak detector is raised, the refrigerant leak detector could operate wrongly since it detects the substances other than halogen gas.

Therefore, use the refrigerant leak detector for HFC refrigerant to check if there is gas leakage. Such a refrigerant leak detector is supersensitive.

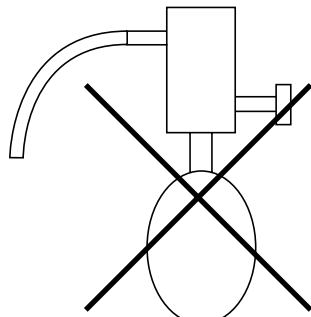

Halide torch

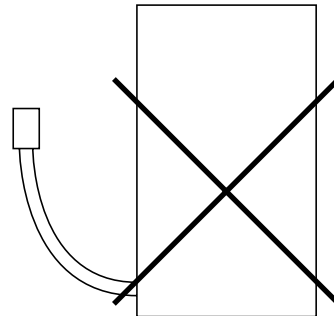

Refrigerant leak detector for R22



Caution

Use the refrigerant leak detector for HFC refrigerant.

6.3 Procedures

Be sure to check if the refrigerant leaks from the processed part of pipe (connected part of flare nut or brazed part). (Applying soapy water to the part where the refrigerant leak detector detects gas leakage makes it easy to find the exact part where the gas leaks.)

Note: Wipe soapy water well after checking.

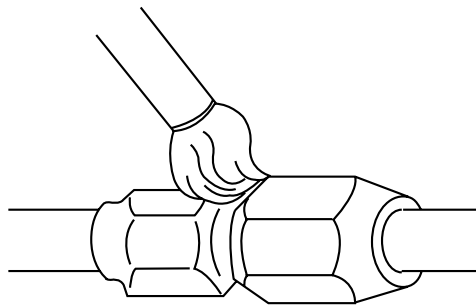

7. Reusing the Existing Pipe

7.1 Checking procedures when reusing the existing pipe For power-inverter air conditioner (1) Checking procedures

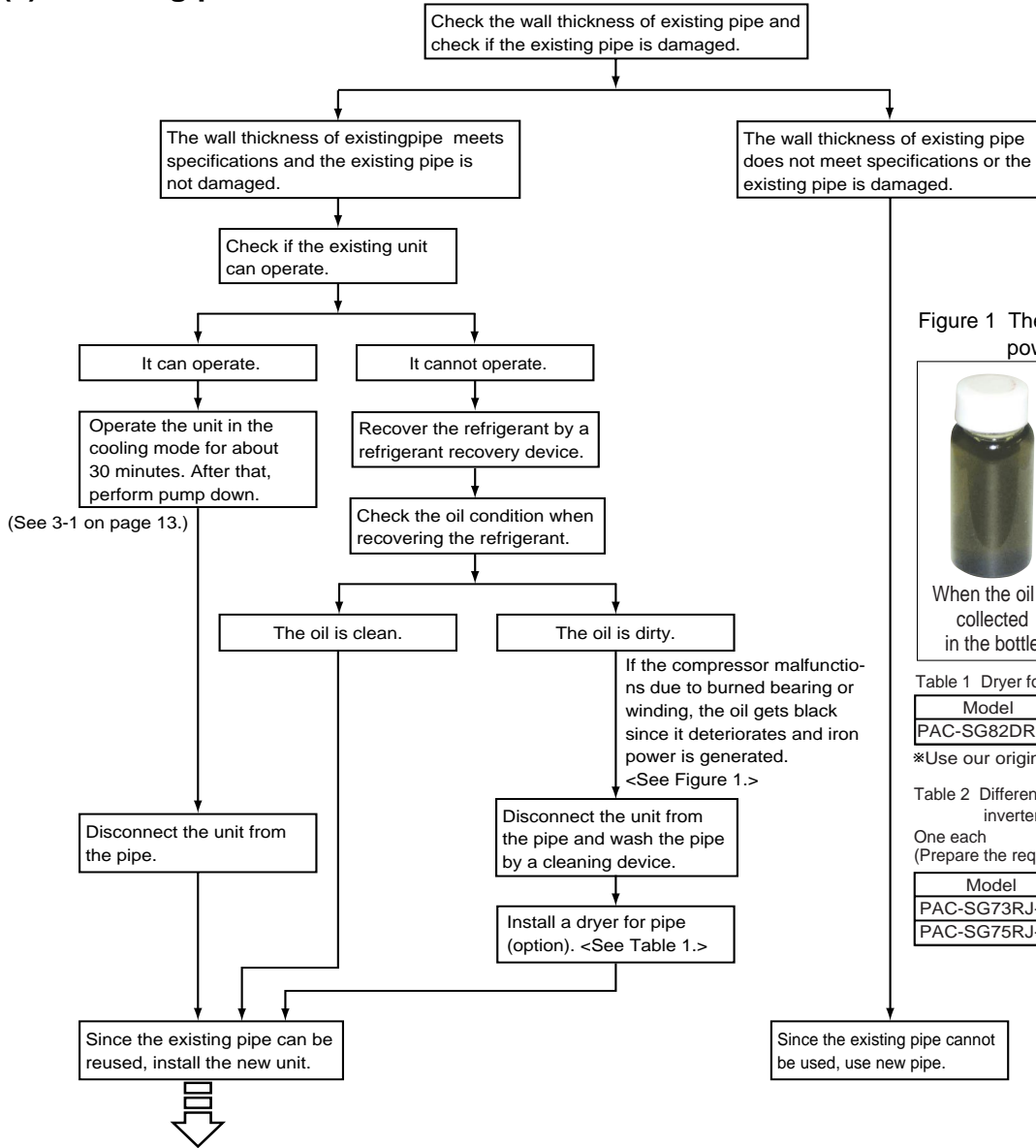

Figure 1 The oil gets black with iron powder remained.



Table 1 Dryer for pipe (option)

Model	Specification
PAC-SG82DR-E	For liquid pipe $\phi 9.52$

*Use our original dryer.

Table 2 Different-diameter joint for power-inverter air conditioner (option)

One each
(Prepare the required number of joints.)

Model	Unit side \rightarrow Pipe side
PAC-SG73RJ-E	$\phi 9.52 \rightarrow \phi 12.7$
PAC-SG75RJ-E	$\phi 15.88 \rightarrow \phi 19.05$

- When installing new unit**
- ① Reprocess the flared part of pipe to make it suitable for R410A.
Use the flare nut attached to the indoor/outdoor units.
 - ② If the gas pipe ($\phi 19.05$) is used for RP4, RP5, RP6
Set DIP SW8-1 on the outdoor control P.C. board to ON. (See Photo 1.)
*This is to restrict the pressure applied to the pipe within the allowable one.
.Use the different-diameter joint (option) (See Table 2.) or perform brazing to change the size of gas pipe.
 - ③ If the gas pipe is used for RP3 by making its diameter bigger
Set DIP SW8-1 on the outdoor control P.C. board to ON. (See Photo 1.)
*This is to prevent the capability of collecting the oil in the power receiver from decreasing with the decrease in refrigerant flow rate.
.Use the different-diameter joint (option) (See Table 2.) or perform brazing to change the size of gas pipe.
 - ④ If the size of existing pipe is different from the standard size
The existing pipe can be used as shown on the next page.
.Use the different-diameter joint (option) (See Table 2.) or perform brazing to change the size of existing pipe.
- ☆If the existing pipe is used for RP4, RP5, RP6
Set DIP SW8-2 on the outdoor control P.C. board to ON. (See Photo 1.) Then the unit starts pipe washing operation.
*The replacement filter recovers chemical compound containing chlorine remained in the existing pipe. (Photo 1)
.The unit equipped with the replacement filter operates automatically in the cooling mode for about 2 hours.

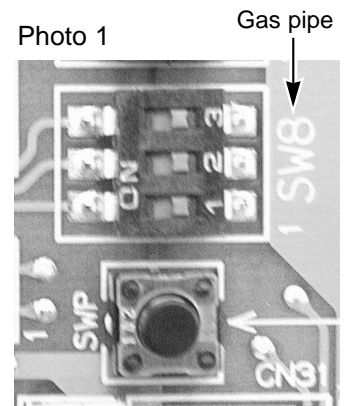

(2) Applicable extension pipe for each model

● 1:1 system

(a) Pipe length

<Table 1> Pipe length for 1:1 system

Liquid pipe (mm)	OD	φ6.35			φ9.52			φ12.7	
	Thick-ness	t0.8			t0.8			t0.8	
Gas pipe (mm)	OD	φ9.52	φ12.7	φ15.88	φ12.7	φ15.88	φ19.05	φ15.88	φ19.05
	Thick-ness	t0.8	t0.8	t1.0	t0.8	t1.0	t1.0	t1.0	t1.0
RP3	×	□10m	○10m	□30m	◎50m	×	△30m	×	
RP4	×	×	×	×	◎75m (*2)	○50m (*1)	△50m	△50m (*1)	
RP5	×	×	×	×	◎75m (*2)	○50m (*1)	△50m	△50m (*1)	
RP6	×	×	×	×	◎75m (*2)	○50m (*1)	△50m	△50m (*1)	

*1: Set DIP SW8-1 on outdoor unit controller board to ON.

*2: The maximum length is 50 m in case of using existing pipes.

*3: The height difference between indoor and outdoor unit should be kept within 30 m for all models.

[Marks in the table above]

◎ : Normal piping

△ : It can be used, however, additional refrigerant charge is required when the pipe length exceeds 20m. ➡ Refer to table 4.

× : It cannot be used.

○ : It can be used.

□ : It can be used, however, the capacity is lowered. ➡ Refer to 11 Capacity correction.

(b) Adjusting the amount of refrigerant

Additional refrigerant charge is not necessary for the pipe length up to 30 m. When the pipe length exceeds 30 m or service (refrigerant replacement) is performed, charge proper amount of refrigerant for each pipe length referring to table below.

Use refrigerant R410A. Use charge hose exclusive for R410A.

- When charging additional refrigerant, charge the refrigerant from low-pressure side of the port valve using a safety charger.
- Make sure that air purge for this unit at refrigerant replacement is performed from both high-pressure check valve and service port. (If air purge is performed only from one of them, air in not purged enough.)
- When replacing refrigerant, charge the refrigerant from service port. When charged refrigerant is less than specified amount, charge the refrigerant again from low pressure side of the port valve using a safety charger.
- Tighten the service port cap (nut) of stop valve firmly.

The tightening torque is 12 to 16 N·m. (For the prevention of slow-leak)

- Check additional refrigerant charging amount referring to table 4 when liquid pipe is one size larger than standard diameter, and table 2 when the pipe is standard diameter.

<Table 2> Additional refrigerant charging amount for pipe of standard diameter

Outdoor unit	Permitted pipe length	Additional refrigerant charging amount for pipe length exceeding 30 m (kg)				Number of bends	Height difference
		31 — 40m	41 — 50m	51 — 60m	61 — 75m		
PUHZ-RP3	50m or below	0.6Kg	1.2Kg	—	—	15	30m or above
PUHZ-RP4 — RP6	75m or below	0.6kg	1.2kg	1.8kg	2.4kg		

<Table 3>

Outdoor unit	Permitted pipe length	Additional refrigerant charging amount for recharging (above) and pipe length exceeding 30m (below) (kg)						
		10m or below	11 — 20m	21 — 30m	31 — 40m	41 — 50m	51 — 60m	61 — 75m
PUHZ-RP3	50m or below	3.1	3.3	3.5	4.1	4.7	—	—
					0.6	1.2	—	—
PUHZ-RP4 — RP6	75m or below	5.1	5.3	5.5	6.1	6.7	7.3	7.9
					0.6	1.2	1.8	2.4

<Table 4> Additional refrigerant charging amount for liquid pipe which is one size larger than standard diameter

	Liquid pipe dia	Chargeless	Max. pipe length	Additional refrigerant charging amount
RP3	φ12.7	20m	30m	100 g addition per 1 m when pipe length exceeds 20 m
RP4 — RP6	φ12.7	20m	50m	100 g addition per 1 m when pipe length exceeds 20 m

(3) Refrigerant recovery (pump down): For power-inverter air conditioner

Follow the procedures to recover refrigerant when the indoor unit or the outdoor unit is moved or newly installed.

① Before performing refrigerant recovery operation, make sure all the "SW5 for function changes" on the outdoor control P.C. board are set to OFF. If they are not, record the settings first, then return all the SW5 to OFF and start refrigerant recovery operation.

After moving the unit to a new location and finishing the test run, set SW5 to the previously recorded settings.

② Turn on the power supply (breaker).

*Make sure the display "Centrally controlled" does not appear on the screen of the remote controller.

If pump down is performed with the display "Centrally controlled" appeared, it cannot be finished properly.

③ Close the stop valve on liquid pipe side first, then set the pump down switch SWP on the outdoor control P.C. board to ON. The compressor and the fan (indoor/outdoor units) start refrigerant recovery operation.

(LED 1 and 2 on the outdoor control P.C. board light.)

*Be sure to set the pump down switch to ON (Press the switch.) while the unit stops.

Even if the unit is stopping, the refrigerant recovery operation is not performed within about 3 minutes after the compressor stops. In this case, wait for about 3 minutes after the compressor stops, and set the pump down switch SWP to ON again.

④ After the refrigerant recovery operation is performed for 2-3 minutes, the unit stops automatically (LED 1 does not light and LED 2 lights.) Then, close the stop valve on gas pipe side immediately.

*If LED 1 lights and LED 2 does not light when the unit stops, fully open the stop valve on liquid pipe side and do over again from step 3 in 3 minutes or more.

*If the recovery refrigerant operation has been finished properly (LED 1 does not light and LED 2 lights.), the unit remains stopped until the power supply is turned off.

⑤ Turn off the power supply (breaker).

3-1) Pump down procedures: For units using R22 or R407C

Operate the unit in the cooling mode for 30 minutes and then recover the oil coming out of the compressor into the compressor. After that, close the valve of liquid pipe and perform pump down.

When closing the valve of liquid pipe and performing pump down just after the compressor starts operating, a great deal of oil coming out of the compressor could remain in the pipe, and this may result in the decrease in the unit's capacity or a malfunction of compressor, etc.

3-2) Why does oil get dirty?

If the compressor malfunctions due to the burning of bearing or winding, the oil gets black since it deteriorates and iron powder is generated, and a great deal of iron powder or deteriorated oil could remain in the pipe. If the pipe is used as it is, the unit could malfunction easily. Therefore, replace the pipe with new one, or wash the pipe using R22.

7.2 Reprocessing of pipe end and Operation when reusing the existing pipe

When reusing the existing pipe, reprocess the flared part of pipe to make it suitable for R410A. Moreover, replace the flare nut with one attached to the unit.

(1) Power-inverter operation

·As for RP4,RP5,RP6, be sure to perform power-inverter operation before test run when using the existing pipe for R22.

- ①There is no need for this operation if new pipe is used.
- ②As for RP3, there is no need for this operation even if the existing pipe for R22 is used.
(The power-inverter operation cannot be performed.)

·Procedures for power-inverter operation

- ①Turn on the power supply.
- ②Set SW8-3 on the outdoor control P.C. board to ON to start power-inverter operation.
 - Since the power-inverter operation is performed in the cooling mode, the indoor unit blows out cool air during this operation.
 - During the power-inverter operation, LED 1 and 2 on the outdoor control P.C. board blink at the same time with the display "Test run" appeared on the screen of the remote controller.
- ③Be sure to perform the power-inverter operation for 2 hours or more.
 - The unit stops power-inverter operation automatically 2hours after setting SW8-2 to ON.
 - Since the power-inverter operation can be repeated by changing the setting of SW8-2 from OFF to ON, be sure to perform the operation for 2 hours or more. (If the operation time is less than 2 hours, the unit could be damaged since the existing pipe is not washed fully.)
- ④Set SW8-2 to OFF. (Now, the power-inverter operation has been finished.)
 - ※The compressor may operate continuously at the room temperature less than 15°, however, this is not a function of unit.

(2) Test run

·Operation from outdoor unit...Use the dip switch SW4 on the outdoor control P.C. board to start/stop the test run and to set the operation mode (Cooling or Heating).

- ①Use SW4-2 to set the operation mode (Cooling or Heating).
- ②Set SW4-1 to ON. Then, the test run starts according to the operation mode set by SW4-2.
- ③Set SW4-1 to OFF to stop the test run.

·After turning on the power supply, a small clicking noise may be heard from the machine chamber, this is because the electronic expansion valve works to adjust the opening.

Therefore, this sound does not show a malfunction of unit.

·A clanging noise may be heard from the machine chamber for a few seconds after the compressor starts operating.

This sound generates from the valve element located the inside of the restrictor valve

since the differential pressure in the pipe is small. Therefore, this sound does not show a malfunction of unit.

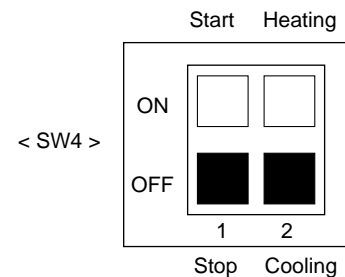

※The operation mode cannot be changed by SW4-2 during the test run.

(To change the operation mode of test run, stop the test run by SW4-1 first. Then change the operation mode and resume the test run by SW4-1.)

8. Tools for Installation

8.1 Necessary tools

(1) For R410A

-Gauge manifold valve exclusive for R410A

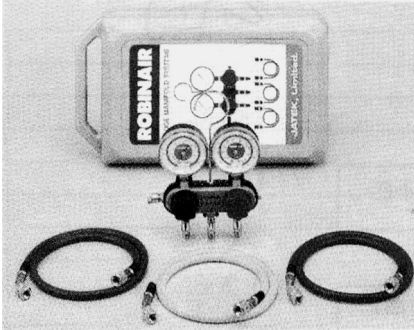

To avoid charging R22, the diameters of screws for each part are changed. Moreover, the pink sticker is affixed on this gauge manifold so that the installer can distinguish between this one and the gauge manifold for R22.

-Flare tool for R410A

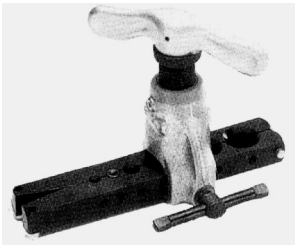

-Flare gauge

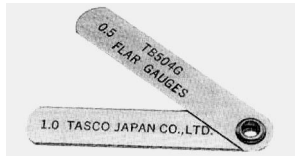

Flare tool

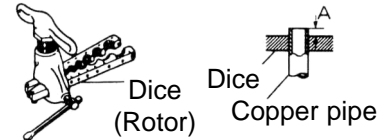

Pipe diameter [mm]	A[mm]		
	When the tool for R410A is used	When the tool for R22 is used	
	Clutch type	Clutch type	Wing nut type
6.35	0 - 0.5	1.0 - 1.5	1.5 - 2.0
9.52	0 - 0.5	1.0 - 1.5	1.5 - 2.0
12.7	0 - 0.5	1.0 - 1.5	2.0 - 2.5
15.88	0 - 0.5	1.0 - 1.5	2.0 - 2.5
19.05	0 - 0.5	1.0 - 1.5	2.0 - 2.5

If the tool for R22 is used to flare the copper pipe for R410A, make the dimension "A" bigger than the case where the copper pipe for R22 is to be flared so that the flared part of pipe can meet the specified dimension. The dimension "A" can be secured by using the flare gauge for adjusting the part of pipe protruded from the dice.

(2) For environmental protection

-Vacuum pump equipped with backflow prevention function

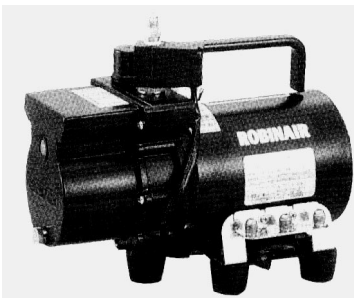

-Backflow prevention device



Equipping the vacuum pump with the backflow prevention function prevents the oil in the vacuum pump from going into the refrigerant cycle when the vacuum pump stops for some reason. Using the backflow prevention device makes it possible to use the conventional vacuum pump for R22.

& Vacuum pump for R22

(3) For securing quality

-Torque wrench

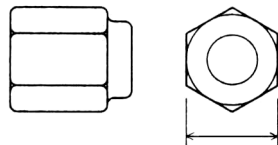
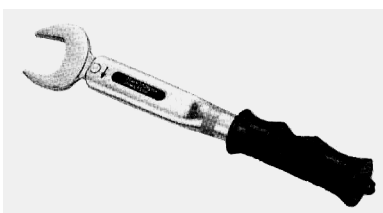

Dimension "B"

Use the torque wrench to tighten the flare nut with appropriate torque to prevent refrigerant from leaking due to insufficient tightening of flare nut and to prevent the flared part of copper pipe being damaged due to excessive tightening of flare nut.

Nominal diameter	Outside diameter [mm]	Dimension "B"		Torque
		R22	R410A	
1/4"	6.35	17	17	18N · m(180kgf · cm)
3/8"	9.52	22	22	42N · m(420kgf · cm)
1/2"	12.7	24	26	55N · m(550kgf · cm)
5/8"	15.88	27	29	75N · m(750kgf · cm)
5/8"	15.88	—	36	100N · m(1000kgf · cm)
3/4"	19.05	36	36	100N · m(1000kgf · cm)

※

※for indoor unit of RP4,5,6 models.

8.2 Convenient tools

(1) For securing quality

-Refrigerant leak detector



Since the refrigerant leak detector for R22 has low accuracy for detecting HFC refrigerant (R410A and R407C), the refrigerant leak detector exclusive for HFC refrigerant is needed.

-Thermistor vacuum gauge

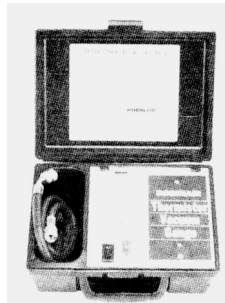

It can be used to check ultimate vacuum and refrigerant leakage exactly. Therefore, this gauge makes it possible to carry out proper operation and to find out when the vacuum drying will be finished.

A vacuum gauge can be used as an alternative for thermistor vacuum gauge. If the vacuum gauge is used, be sure to use the vacuum valve to prevent the pressure of refrigerant from being applied to the vacuum

gauge and to prevent the oil from flowing backward.

-Vacuum valve

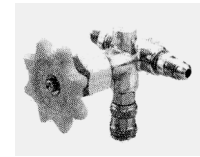

It is used to connect the vacuum pump to the vacuum gauge.

9. Tools for Refrigerant Charge

9.1 Necessary tools

(1) For R410A

-Electronic scale for refrigerant charge



When the outside temperature is high, refrigerant is easy to foam in the charging cylinder for R410A and this makes it difficult to calculate the amount of refrigerant. Therefore, the scale is recommended for refrigerant charge.

-R410A gas cylinder for refrigerant charge



If the gas cylinder is equipped with the siphon, the refrigerant can be taken out without turning the gas cylinder upside down.

-Charge mouth for R410A gas cylinder

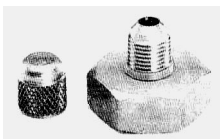

Though the diameter of mouth connected to the gas cylinder side is W26-14, same as heretofore, the diameter of mouth connected to the charge hose side is changed to UNF 1/2-20 (Flare size: 5/16).

9.2 Convenient tools

(1) For environmental protection

-Charge valve



It prevents the gas from coming out of the charge hose and the unit when the hose is removed.

This makes it possible to open/close the valve at the hose end.

(2) For securing quality

-Safety charger



Since it turns refrigerant into mist, there will be no extra pressure to the compressor and the refrigerant can be charged more easily.

10. Checking the Operation Condition

10.1 Positions and items to be measured

- The followings are the positions and items to be measured and the pressure and temperature close to the standard operation conditions specified by Japan Industrial Standards (JIS).
- Measure the pressure and the temperature, referring to the measurement method in the table below.
- Carry out measurement after the refrigerant circuit gets to be stable. (It takes 30 minutes to 1 hour until the circuit becomes stable.)

	Items to be measured	Pressure and temperature close to standard operation conditions specified by JIS	Measurement method and Remarks
A	High pressure (MPa)	Cooling: 2.3 - 3.0 Heating: 2.0 - 3.2	Connect the pressure gauge to the check valve on high-pressure side.
B	Low pressure (MPa)	0.55 - 1.0	Connect the pressure gauge to the check valve on low-pressure side.
C	Discharge pipe temperature (°C)	50 - 100	Measure it by the thermometer on the pipe surface.
D	Suction pipe temperature (°C)	-2 - +18	Measure it by the thermometer on the pipe surface.
E	Indoor suction temperature (°C)	Cooling: 27 Heating: 20	It can be displayed on the screen of the remote controller.
F	Indoor discharge temperature (°C)	Cooling: 8 - 20 Heating: 30 - 50	
G	Outdoor suction temperature (°C)	Cooling: 35 Heating: 7	Measure it by the thermometer on the pipe surface.
H	Outdoor discharge temperature (°C)	Cooling: 40 - 50 Heating: 0 - 5	Measure it by the thermometer on the pipe surface.

Note: For inverter air conditioner, the operation condition changes according to the operating frequency of compressor.

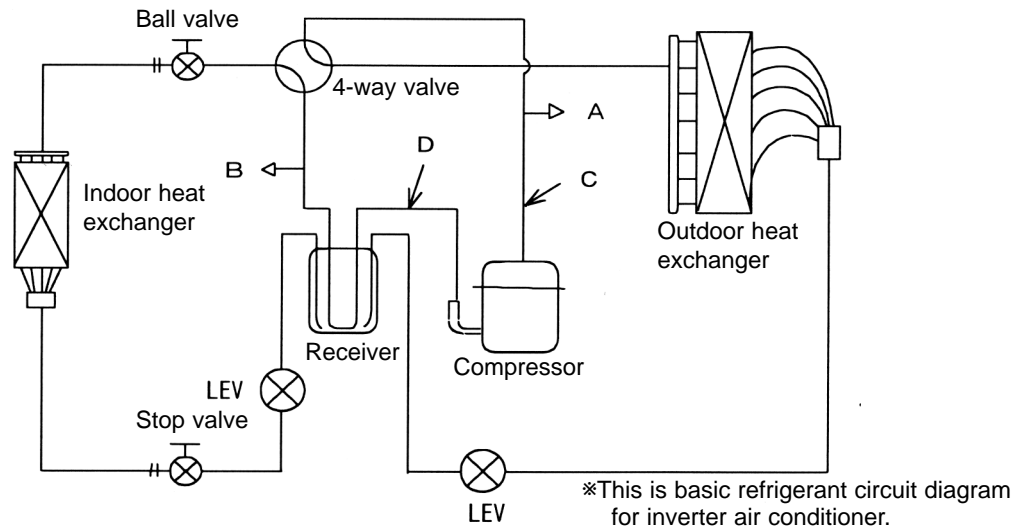

10.2 Operating pressure range

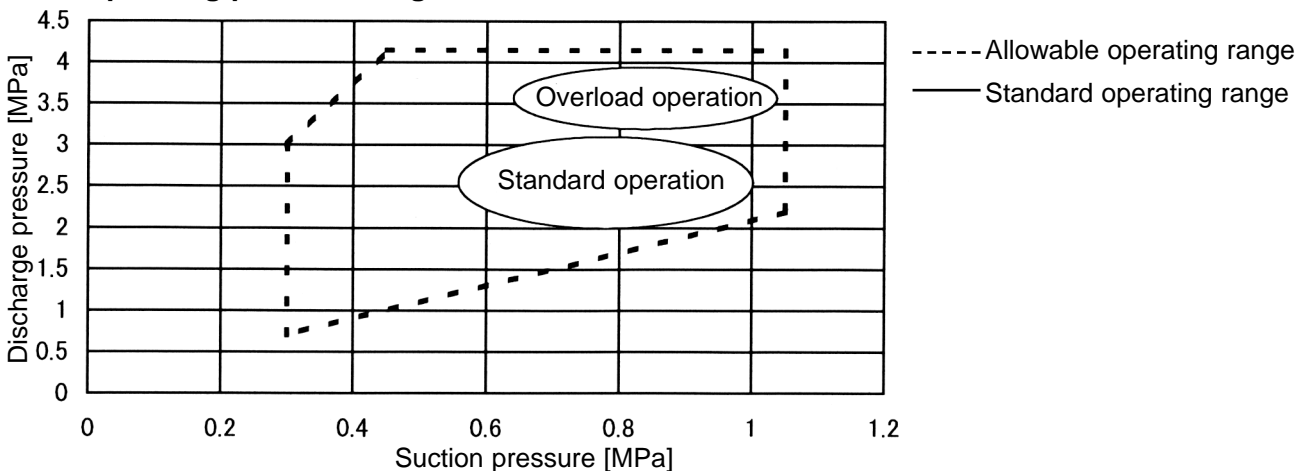

11. Capacity correction

Cooling and heating capacity is lowered according to pipe length. Capacity can be obtained by referring to the capacity curves below. When the diameter of gas pipe is one size smaller than standard diameter, cooling capacity is lowered comparing to the standard diameter. The lowered capacity can be obtained by referring to capacity curves for gas pipe which is one size smaller than standard size.

Corrected pipe length (m) = actual pipe length (m) + number of bends x 0.3 (m) becomes stable.)

① Capacity curves for PUHZ-RP • HA model <Standard size>

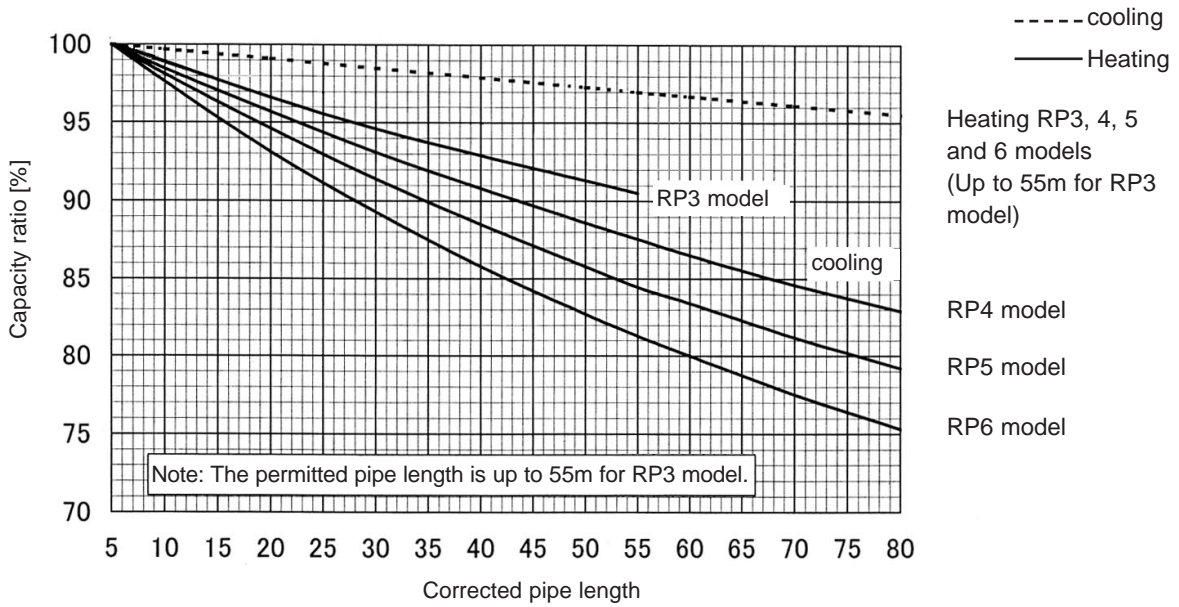

② Capacity curve for PUHZ-RP3 model

<When gas pipe is one size smaller than standard size>

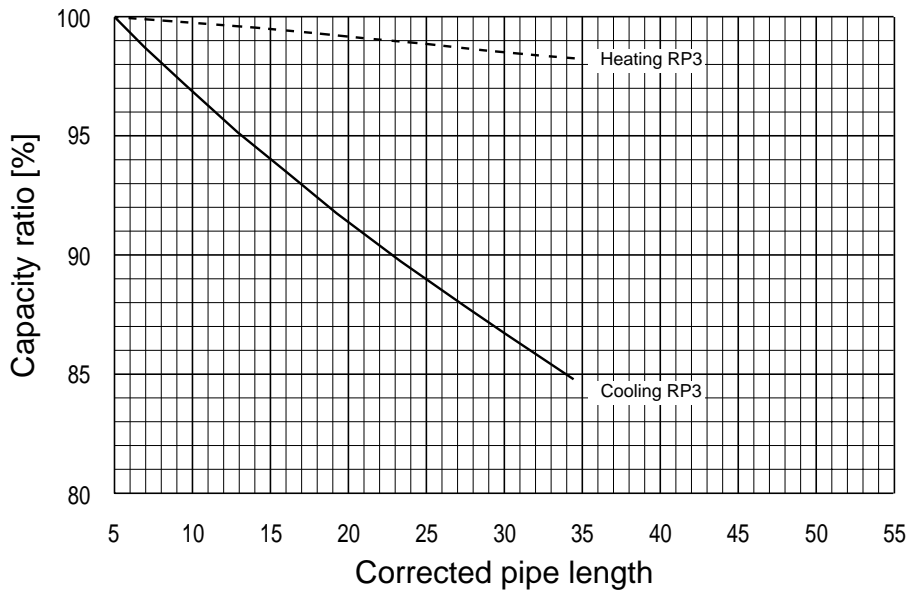

③ When gas pipe is one size larger than standard size for PUHZ-RP4, 5 and 6.

① Capacity can be obtained by referring to capacity curves of standard size.

12. Field electrical wiring (Power wiring specification)

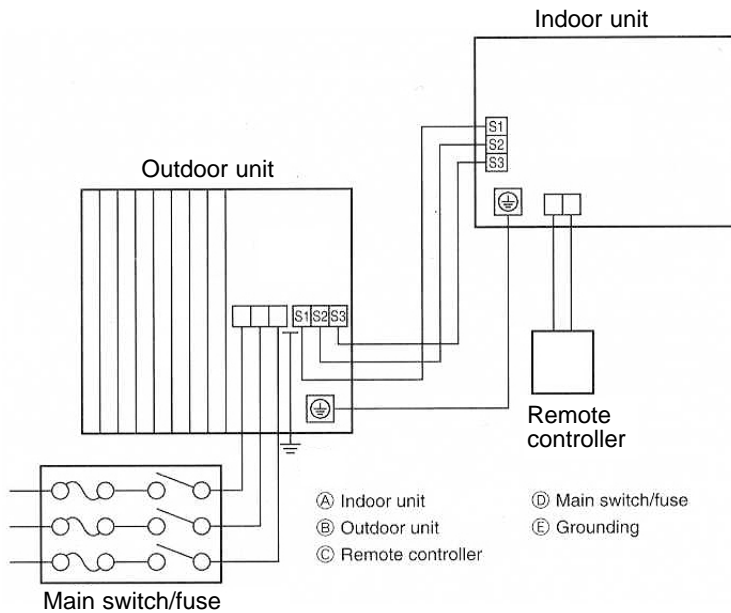

Models (Outdoor unit)		RP2,5,3	RP4,5	RP6
Indoor unit power supply		~/N (Single),50Hz,220 - 230 -240V		
Outdoor unit Power supply	Phase	~/N (Single)		
	Frequency & Voltage	50 Hz,220 - 230 -240V		
Input capacity	Indoor unit (A)	-	-	-
Main switch/Fuse	Outdoor unit (A)	25 / 25	32 / 32	40 / 40
Wiring	Outdoor unit Power supply	Wire No.	3	3
	Indoor unit/Outdoor unit connecting		3 x 2.5 Cable (polar)	
	Remote controller-Indoor unit		Cable 2C x 0.69	
		*This wire accessory of remote controller (Wire length: 10m, Non-polar)		
Control circuit rating		Indoor unit-Outdoor unit: S1-S2 AC 220 - 230 - 240V,S2-S3 DC24V, Remote controller-Indoor unit: DC14V		

Notes:

- 1.Wiring size must comply with the applicable local and national code.
- 2.Be careful about choosing the installation location for the earth leakage breaker and how it is installed as the initial electric current may cause it to malfunction.
- 3.Power supply cords and Indoor/Outdoor unit connection cords shall not be lighter than polychloroprene sheathed flexible cord.(design 245 IEC 57)

The earth leakage breaker used for power-inverter air conditioner needs to be the one exclusive for inverter (the one taken measures against higher harmonic and surge). There are two kinds of earth leakage breakers. One is for general use and another is the one taken measures against higher harmonic and surge.

When the unit is newly installed, using the existing earth leakage breaker for general use (the one that is not designed for inverter) could cause shutoff unnecessarily by higher harmonic current generated from the inverter air conditioner.

What is the earth leakage breaker exclusive for inverter?

The inverter air conditioner rectifies AC to DC and then changes DC to AC at any frequency since the high-speed switching element turns on and off automatically. Therefore, higher harmonic current generates more frequently in the inverter air conditioner than in the non-inverter air conditioner, and the inverter air conditioner could cause shutoff unnecessarily due to the capacitive coupling with the earth.

As a result, the earth leakage breaker exclusive for inverter (the one taken measures against higher harmonic and surge) is the one designed to be less subject to higher harmonic to prevent such unnecessary shutoff.

13. Check List for Existing Pipe Work

Check the followings when the existing pipe is used.

Installation procedures		Check points		Check mark	
Before installation	①	Make sure the existing pipe is not the one used in the air conditioner of gas/oil heat pump type.			
	②	When two or three indoor units are connected to one outdoor unit, check if our original distribution pipe is used. (If it is not used, change the distribution pipe to our original one.)			
	③	Prepare the tools that can be used for R410A or the ones exclusive for R410A.			
	④	If the different-diameter pipe is used, make sure the pipe length is within the specified maximum one.(See page 12.)			
	⑤	Make sure the outside and inside of existing pipe are clean and that there is no sulfur, oxide, dust or warf that is harmful for use.			
	⑥	Use the existing pipe whose wall thickness is t0.8mm or more (t1.0mm or more for the pipe of $\phi 15.88$ and $\phi 19.05$). (See page 5.)			
	⑦	Make sure the existing pipe is not damaged.			
Installation	①	Check if the existing unit can operate.	Possible	· Operate the unit in the cooling mode for 30 minutes and then perform pump down.	
			Impossible	· Recover refrigerant by the refrigerant recovery device.	
		· Check if the oil is dirty. (See page 11.)			
		· If the oil is dirty, wash the pipe by the cleaning device.			
	· If the oil is dirty, install a dryer for pipe after washing the pipe (recommended).				
	②	Replace the flare nut with one attached to the unit.			
③	Reprocess the flared part of pipe to make it suitable for R410A. (See page 5.)				
④	When processing the flared part of pipe, make sure no burr or foreign material goes into the pipe.				
⑤	Apply a small amount of ester oil, ethereal oil or alkyl benzene oil as refrigerant oil to the flared part of pipe.				
Connecting the refrigerant pipe	①	Use the torque wrench to tighten the flare nut.			
	②	RP3	· When making the size of gas pipe bigger, set DIP SW8-1 on the outdoor control P.C. board to ON. (See page 11 and 12.)		
RP4,RP5,RP6		· When the gas pipe ($\phi 19.05$) is used, set DIP SW8-1 on the outdoor control P.C. board to ON. (See page 11 and 12.)			
Airtight test	①	Be sure to close the stop valve and ball valve of outdoor unit.			
	②	Do not use chlorine refrigerant, oxygen or flammable gas as pressurized gas. (The use of oxygen could result in an explosion.)			
Vacuum drying	①	Use the vacuum pump equipped with a backflow prevention function or use the vacuum pump for R22 together with a backflow prevention device.			
	②	Use the tools exclusive for R410A. (Gauge manifold, charge hose, and thermistor vacuum gauge, etc.)			
Additional refrigerant charge	①	Use the refrigerant gas cylinder with siphon. (Turn the gas cylinder upside down if it is not equipped with siphon.)			
	②	Take out R410A from the liquid phase of gas cylinder and charge R410A of gas phase into the unit.			
	③	Use the tools exclusive for R410A. (Electronic scale for refrigerant charge, gauge manifold, charge hose,safety charger, and charge valve, etc.)			
Checking the gas leakage	①	Use the refrigerant leak detector for alternative refrigerant and soapy water for checking.			
Power-inverter operation (only for RP4 - RP6)	①	Set DIP SW8-2 on the outdoor control P.C. board to ON and perform power-inverter operation.			
	②	Perform power-inverter operation for 2 hours or more.			
	③	Set DIP SW8-2 on the outdoor control P.C. board to OFF after finishing the power-inverter operation.			
Others	①	Make sure the heat insulation is sufficient to prevent water from dropping due to insufficient heat insulation.			

Construction Manual for Power-Inverter Air Conditioner

Issued in 2003 For R410A