

Light Metals 2013

**ALUMINUM ALLOYS:
FABRICATION,
CHARACTERIZATION AND
APPLICATIONS**

General Poster Session

APPLICATIONS OF THE HORIZONTAL SQUEEZE CASTING PROCESS FOR AUTOMOTIVE PARTS MANUFACTURING

P. Dulyapraphant^c, E. Kittikhewtraweeserd,
P. Kritboonyarit, N. Denmud

National Metal and Materials Technology Center, Thailand Science Park, Thailand,

Keywords: Horizontal squeeze casting / HPDC / ADC12 / Filling pattern / Age Hardening / Mechanical properties

Abstract

In recent years, the Horizontal Vertical Squeeze Casting (HVSC) process has been used with different aluminium alloys to fabricate high integrity automotive parts. In this study, the Horizontal Squeeze Casting (HSC) process is adopted to cast automotive parts using ADC12 aluminium alloy. To minimize amount of gas porosity inside the squeeze casts, concepts of minimization of ingate velocity and maximization of flow rate along with bottom filling pattern are applied during the cavity filling. The maximum intensification pressure is also applied during solidification in order to ensure the higher cooling rate and minimization of porosities. Based on the experiment, castings can pass a blister test at 490 degree Celsius for 2.5 hours. Then, castings are heat treated by solution treatment at 484 °C for 20 minutes and artificial age at 190 °C for 2.5 hours, respectively. This improves UTS of the heat treated squeeze cast to 254.14 MPa with 1.84% of elongation.

Introduction

Compressed Gas porosities inside a casting are the main disadvantage of a High Pressure Die Casting (HPDC) process. Not only directly affect the mechanical properties of a casting by acting as an initial point of parts' failure, they also inhibit the casting to be heat treated in order to improve castings' mechanical properties. A squeeze casting process is developed to alleviate those problems by minimizing amount of gas inside castings.

According to M.R. Ghomashchi and A. Vikhrov [1], two types of squeeze casting process; direct and indirect process, have been developed based on metal's movement during die filling. For the direct squeeze casting process, molten metal is poured into an open die, then hydraulic ram is moved down to apply the pressure on the solidifying liquid metal. This results in uncontrollable flow pattern and speed of liquid metal. Turbulent flow, the entrapment of air and brittle surface oxide films inside casting can be expected [1].

On the other hand, the indirect squeeze casting process controls flow pattern and speed of liquid metal by the injection speed of a plunger during the die filling. As the cavity is fully filled, an intensification pressure is applied to the solidifying liquid metal.

Chattopadhyay, H. and Morton, J.R. [2,3] have been reported that mechanical properties of squeeze casts can be as good as wrought products of similar composition. Wei-ping, [4] studies squeeze casts of Al-Cu alloy and reports that castings from a squeeze casting process have finer microstructure, higher density, toughness, and hardness than those from a gravity die casting process. It is believed that the higher mechanical properties of the squeeze castings resulted from the non-turbulent filling of liquid metal and the better cooling rate during solidification under the intensification pressure.

To achieve the laminar flow filling pattern in squeeze casting processes, many literatures [4,6,7,8] have reported that ideal velocity of liquid metal passing through the ingate should be between 0.1 – 0.5 m/sec. Campbell [5] also reported that melt front's speed should be less than 0.4 m/sec in order to achieve the laminar flow. However, most of literatures are confined to the use of the HVSC process.

In this study, the indirect Horizontal Squeeze Casting (HSC) process is adopted to cast automotive components originally produced by a high pressure die casting process. Depending upon shape and dimensions of the castings, melt's speed might be higher than the level reported by the literatures. As a result, a full laminar flow may not be achieved. This results from the fact that gating system is confined by the shape and dimension of part. In this study, the concept of maximum flow rate with minimum speed of liquid metal passing through the ingates are applied by maximizing ingate area of the gating system based on the casting's shape and dimension.

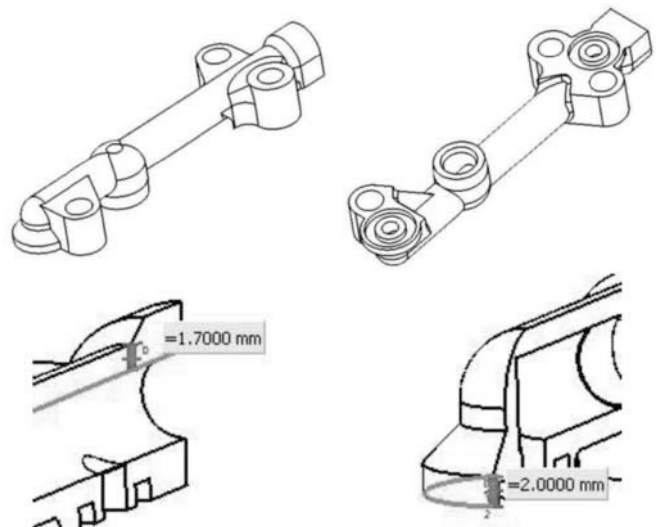

Fig.1 Shape Configuration of the case study part.

Experiment

The goal of this experiment is to apply the concept of the indirect squeeze casting process to cast a part with minimum gas porosities in which castings can be heat treated. An ADC12 motorcycle's part shown in Figure 1 is used as case study. This part is casted on a typical cold chamber die casting machine with horizontal clamping and injection system. Commercial casting process simulation software is used for die design and process setup.

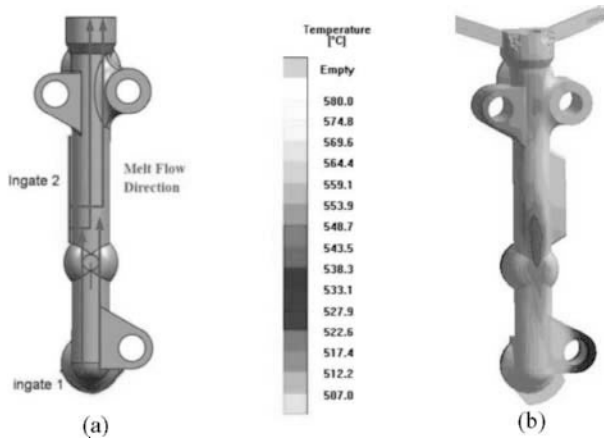

Figure 2. (a) Designed ingates' locations and expected flow direction of liquid metal during the die filling, (b) temperature distribution of liquid metal during the die filling from simulation program.

Three criteria: (1) bottom filling pattern, (2) maximum flow rate and intensification pressure, and (3) minimum melt's speed at ingate are used to design tooling and process condition in order to minimize gas porosities inside castings. To achieve the bottom filling pattern and maximize the flow rate, ingates are placed at two positions; (1) at the bottom of the casting, named ingate1 and, (2) at the middle of the casting, named ingate2 as shown in Figure 2.

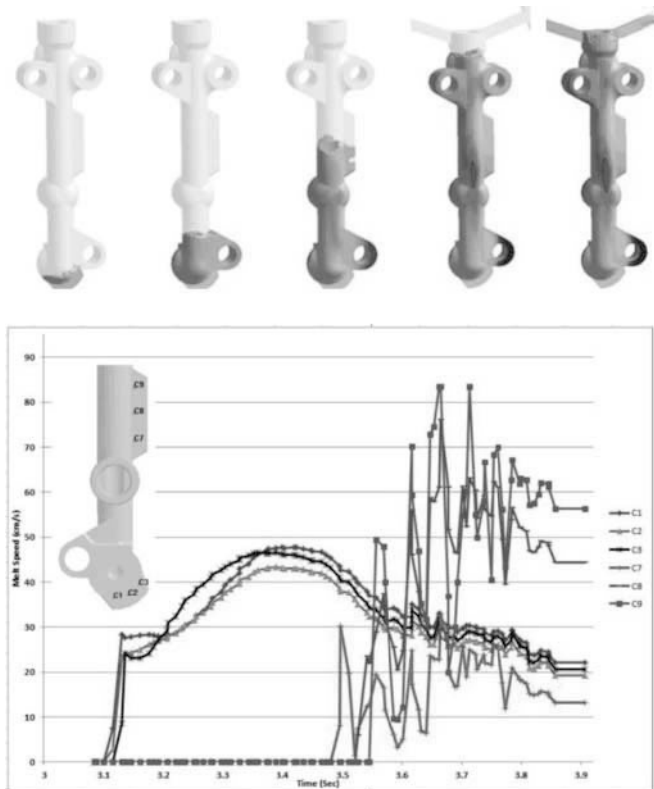

Figure 3. Ideal filling pattern, temperature distribution, and melt's speed at ingate with plunger speed at 0.02 m/sec

Bottom filling pattern is achieved, by controlling the liquid metal to enter the cavity at ingate1 first, and later when liquid metal from ingate1 reach the ingate2 melt stream from ingate2 is combined with that from ingate1 to fill upward to the top of cavity. Vents are located at the top of the part to achieve the most effective air ventilation during the cavity's filling.

To obtain maximum casting pressure for intensification, plunger is selected at diameter of 50 mm in order to gain pressure of 156 MPa during the intensification. Once plunger size is selected, the flow rate of the system is controlled by the speed of plunger. This flow rate must be high enough to fully fill the cavity within certain period of time based on the temperature distribution on the surface of the die. Otherwise, a bigger size of plunger must be selected. However a bigger diameter of plunger results in lower intensification pressure. Based on the conservation of mass flow principle, flow rate at plunger is equal those combined from all ingates. Therefore, plunger speed and ingate area are two main factors affecting the speed of liquid metal entering the cavity.

To minimize melt's speed at ingate, area of ingate must be maximized at any flow rate. Area of ingate can be maximized by increasing either ingates' length and/or thickness depending upon parts' shapes and dimensions. The thickness of castings wall at ingate 1 and 2 are 2 and 1.7 mm, respectively. As a result, the thickness of ingate1 and 2 are 1.8 and 1.5mm respectively. Speed of plunger is confined by capability of the die casting machine.

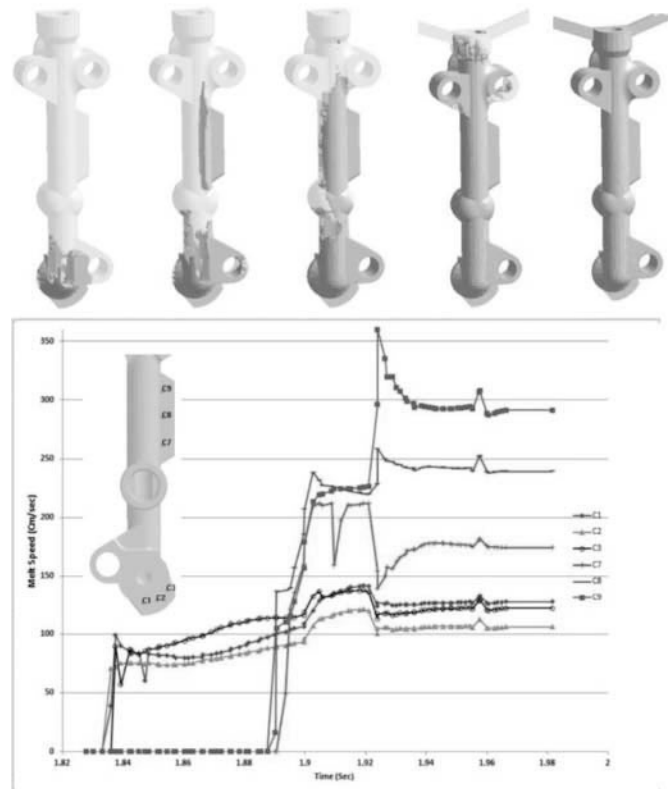

Figure 4. Filling pattern, temperature distribution, and melt's speed at ingate of the real casting condition with plunger speed at 0.1m/sec.

To achieve those criteria, simulation software is used to define the optimal profile of plunger's speed for the ideal

condition. With this profile, the filling pattern and speed of melt at the ingate can be found in Figure 3.

Next die is brought to cast on the 350 ton closing force machine. Also during the casting experiment, simulation result is validated by observing the flow line found on the casting compared with the simulation result as shown in Figure 5.

Results and Discussion

Based on machine capability, a plunger can travel in the range of 0.05 -6.5 m/s for the dry shot speed. When casted with liquid metal, plunger's speed of 0.1 m/sec must be used in order to avoid the surface defects on castings. Melt and die temperature used during the casting experiment are 670, and 200 °C, respectively. Figure 4 shows filling pattern and speed of liquid metal at ingate in the real casting condition. From the simulation results, when using plunger's speed of 0.1m/sec, casting's volume of 9425.13 mm³ can be fully filled within 130 mill-second without any surface defects.



Figure 5. Validation of simulation result with the real casting. From simulation liquid metal from ingate2 (yellow) merge with that of ingate1 (blue) at the middle of the part.

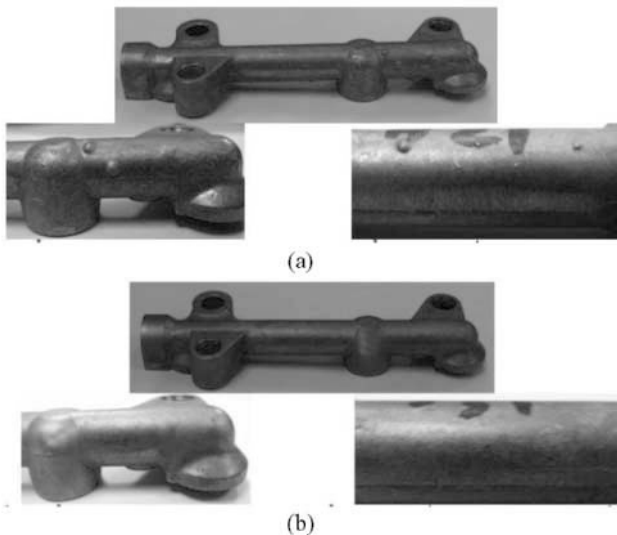

Figure 6. Blister test on castings at 490°C for 2.5 hours (a) HPDC and (b)squeeze casts

Blister test is then performed to check the level of gas porosity inside the castings. From the experiment, castings can with stand up to 490 °C for 2.5 hours of the blister test. This test

condition will be used later to optimize the heat treatment condition in order to improve the mechanical properties of the squeeze casts. The castings from the conventional HPDC process are used as a reference to compare the level of the gas porosity inside.

After the blister test, castings are cut in half as shown in Figure 7 to observe position and size of the porosity inside both HPDC casts and squeeze casts. Furthermore, density test is also performed for both squeeze casts and HPDC casts to indirectly estimate the volume of porosity inside the casting. However, the test does not show significant different results between two processes.

To heat treat the squeeze casts, Lumley [10,11] suggests condition for solution treatment at 480 °C for 15 minutes, and artificial age at 190 °C for 2.5 hours respectively.

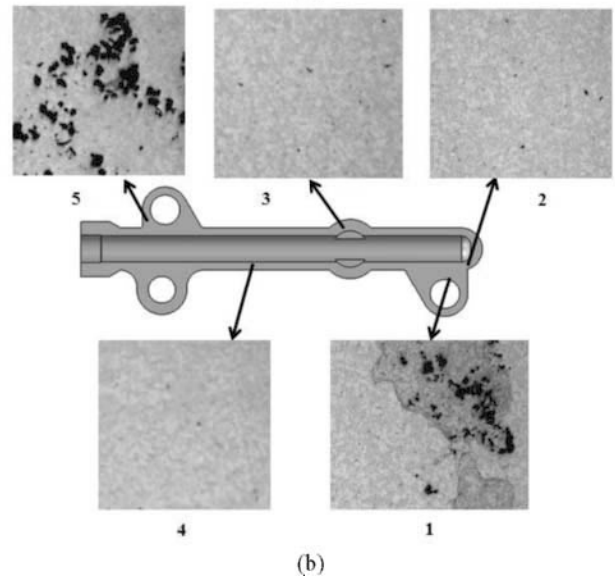
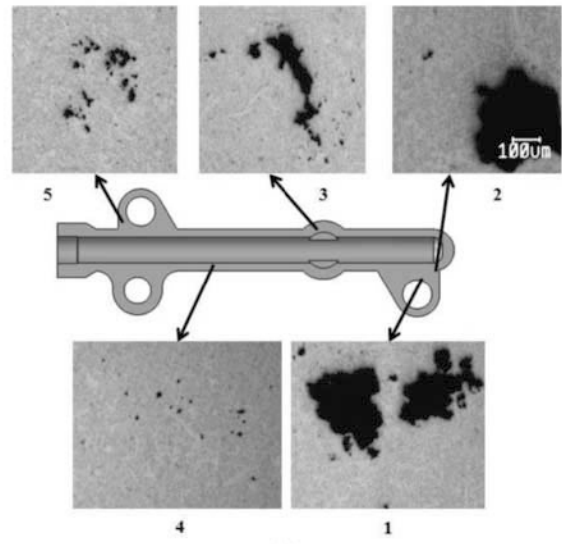

Figure 7. Porosities found inside casts from (a) HPDC, and (b) squeeze, (c) comparison of porosity at location 2 between HPDC and squeeze casts.

By considering the blister test's results and heat treatments condition suggest from literature, heat treatment process for squeeze casts are performed as following condition: solution treatment is done at temperature of 480 °C for 20 minutes while artificial aging is done at 190 °C for 2.5 hours. Variations of temperature of solution treatment are observed as shown in Table 1, while the artificial aging condition remains the same.

Mechanical properties of 6 groups of castings are tested as shown in Table 1 and Figure 9. Sample size of 3 is used for each group of casting. The ultimate tensile strength is calculated from the maximum load used in the test at the time of part failure and divided by the cross section area of the part at the fail location as shown in Figure 8. Elongation and hardness are measured by using the advance video extensometer, and a Macro-Vickers, respectively.

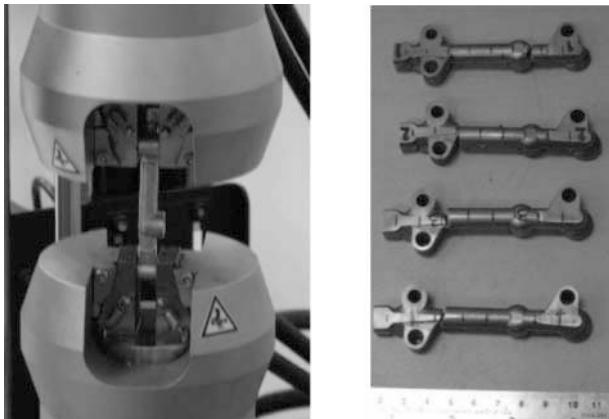

Figure 8. Location of failure on the casting after tensile test.

Table 1. Results of mechanical properties test

	Tensile Strength (MPa)	Elongation (%)	Hardness (HVN)
H1 As Cast	174.71±30.42	0.52±0.18	104.40±4.05
S1 As Cast	198.22±8.31	0.55±0.05	111.00±3.94
S1T6,473	249.74±4.14	1.28±0.25	132.36±4.31
S1T6,484	254.17±2.30	1.84±0.27	134.18±3.94
S1T6,496	257.59±13.41	1.44±0.20	134.81±4.19
S1T6,550	204.18±19.21	0.91±0.10	113.53±3.84

H1 stands for the HPDC cast, S1 stands for the squeeze cast, S1T6 stands for the squeeze cast artificial age at 190 °C for 2.5 hours, 473- 550 stand for temperature used for solution treatment.

From the test results, tensile strength of squeeze casts, both as-cast and heat treated one for solution treatment temperature in the range of 473-496 increases around 14, and 41%, respectively compared with that of the HPDC cast. However, at solution treatment temperature of 550°C, blisters are found on the surface of the casting and tensile strength drop dramatically compared with the others. Elongation and hardness also have the same trend as the tensile strength. In addition, the fluctuation of temperature during the solution treatment in the rank of 30°C seems not to have significant effect on the mechanical properties of the heat treated squeeze casts.

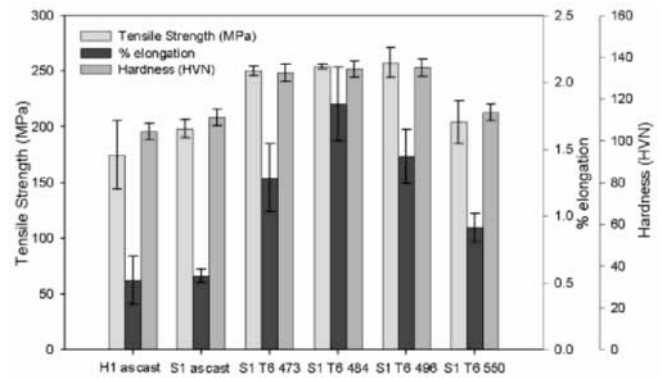

Figure 9. Comparison of Mechanical properties of as-cast and heat treated squeeze casts by using the HPDC cast as a base line.

Summary

1. Squeeze casts with less gas porosities can be successfully casted. With lower gas content inside the casting, parts can be heat treated to increase their mechanical properties.
2. With the use of casting process simulation software, tooling design and process condition setup can be easily achieved. Bottom filling pattern is achieved by using the software to evaluate the location, and dimension of the ingate while speed of melt front can be controlled with in the rank of 1-3 m/sec by varying plunger's speed and ingates' area. This results in the minimization of turbulence and heat loss of the melt during the die filling.
3. Blister test is adopted to indirectly test the amount of gas porosity inside the casting. It is found that squeeze casts can withstand the blister test at 490°C for 2.5 hours. This level of the blister test condition is used as a guideline to plan for the heat treatment condition.
4. From the experiment, the best condition to heat treated the squeeze casts is as follows: solution treatment at 484°C for 20 minutes and artificial age at 190°C for 2.5 hours. With this condition, it results in the ultimate tensile strength of 254.14 ± 2.30 MPa and elongation of $1.84 \pm 0.27\%$.

References

1. M.R. Ghomashchi and A. Vikhrov: Squeeze casting: an overview, Journal of Materials Processing Technology, 2000, pp. 1-9.
2. Chattopadhyay, H., Simulaiton of transport processes in squeeze casting, Journal of Materials Processing Technology (2007), pp. 174-178
3. Morton, J.R. and Barlow, J., Squeeze casting: from a theory to profit and future, J. Inst. Brit. Foundryman (1989)
4. Wei-ping, C., Yuan-yuan, L., Guo-wen, G., Da-tong, Z., Yan, L. and Leo, N.T., Squeeze casting of Al-Cu alloy, J.CENT. SOUTH UNIV. TECHNOL. (2002), pp.159-164
5. John Campbell: Castings, 2nd edition, Butterworth - Heinemann, 2003.
6. Gupta, R.D. and Xia, Y., Squeeze casting: Principles and Applications, DIE CASTING ENGINEER (2004), pp. 54-58.
7. Z. Brown, C. Barnes, J. Bigelow, and P. Dodd: Squeeze Cast Automotive Application and Design considerations, Alluminio e leghe, March 2009, pp. 1-4.
8. J.R. Morton and J.Barlow, Squeeze casting: from a theory to profit and future, J. Inst. Brit. Foundryman, 1989.

9. Wallace, J.F., Chang, Q. and Schwam, D., Process Control in Squeeze Casting (2000), pp.42-48
10. R.N. Lumley, R.G. O' Donnell, M. Givordg, and D.R. Gunasegaram: Heat Treatment of High Pressure Die Castings, Metallurgical and Materials Transactions A, Vol. 38A, October 2007.
11. R.N. Lumley, I.J. Polmear, and P.R. Curtis: Rapid Heat Treatment of Aluminum High-Pressure Die-castings, Metallurgical And Materials Transactions A, Vol. 40A, July 2009.