

PRACTICAL USE OF THE METALVISION ULTRASONIC INCLUSION ANALYZER

Dawid D. Smith¹, Brett Hixson¹
Hugh Mountford², Iain Sommerville².

JW Aluminum¹, 528 Old Mt Holly Road, Goose Creek, South Carolina, 29445, USA
MetalVision Manufacturing (Canada)², 124 Skyway Avenue, Toronto, Ontario, M9W 4Y9, Canada

Keywords: Ultrasonic, Inclusion, Detection, Aluminum.

Abstract

JW Aluminum identified the need to quantify inclusion loads in its molten metal in an effort to deliver higher quality products to its customers. The inclusion detection system had to be able to identify and quantify potential sources of inclusion related defects as well as the benefits from process improvements. This paper describes the validation of principle and measurements made before the final decision to purchase a MetalVision MV20/20 ultrasonic inclusion analyzer. The initial practical experience after purchasing the system obtained is also discussed.

Introduction

The MV20/20 Ultrasonic Inclusion Detection System for molten aluminum is the result of more than 50 years of research and development. The concept of using ultrasonics to detect particles in liquid metals originated during the early years of radar and sonar around World War II. N. Mountford established pioneering work in the U.K. in the late 1940's with British Aluminum. For various reasons, this work was not followed up until the late 1980's, when attempts were made to develop a system for use in liquid steel.

Over the past 20 years, advances in electronics enabled continuous improvements and the commercial availability of the MetalVision MV20/20 system. Fundamental research and development was conducted by N. Mountford and colleagues at the University of Toronto, Canada. Several research papers have been published as a result of this work^{1,2}. MetalVision's MV20/20 equipment has been purchased by several North American and European facilities. Since 2008, the final stages of commercial development include the optimization of hardware performance and the development of more user friendly software. The system provides continuous, in-line, large sample-size metal quality assessment.

Theoretical Investigation

The scientific community is aware that light is electromagnetic waves. Those familiar with the particle vs. wave theory of light also understand that the "resolution" of light is limited by the frequency (wave length) of the visible spectrum. Therefore we have to use the wave properties of an electron (particle) beam to resolve aspects of inclusions in the typical range of 20 to 150 microns.

Electromagnetic waves are an interplay of magnetic and electric fields generated at 180 degree planes that are perpendicular to the direction of propagation. Electromagnetic waves travel at the speed of light. In a vacuum this speed is 299.8×10^6 m/s, but whenever traveling through translucent media, this speed is decelerated, depending on media properties, scattered and eventually eliminated. In contrast to light, pressure (acoustic) waves require a medium and propagation is in the same direction as the movement of the particles that the media consists of. Similar to electromagnetic waves, we can characterize acoustic waves by Hertz or pulses per second and have divided the acoustic wave spectrum into infrasound, (below human detection), audible and ultrasound (above human detection) as given in Figure 1.

Unlike light waves, sound waves generally travel faster through denser media and are totally eliminated in a vacuum. Another characteristic of sound waves is that a single pulse or pressure wave can be delivered (technically therefore close to z). In its most severe case a single pulse can be delivered by a split-second lightning bolt snap, the echoes thereof lasting as the rumble. It is this pulse principle that has been used in sonar to detect objects under water.

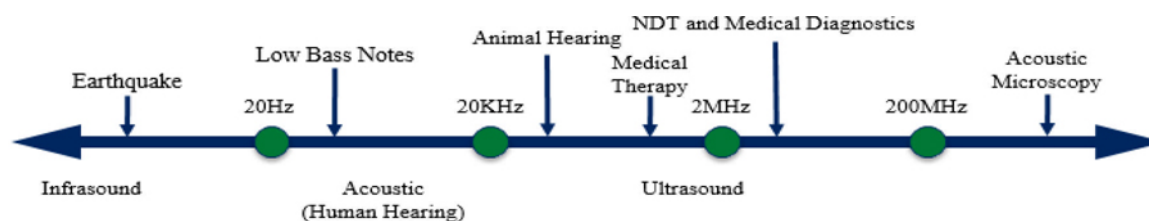

Figure 1: Infrasound, Audible and Ultrasound⁴.

MetalVision Basics

Figure 2 shows the basic components of the MetalVision MV20/20 ultrasonic inclusion analyzer.

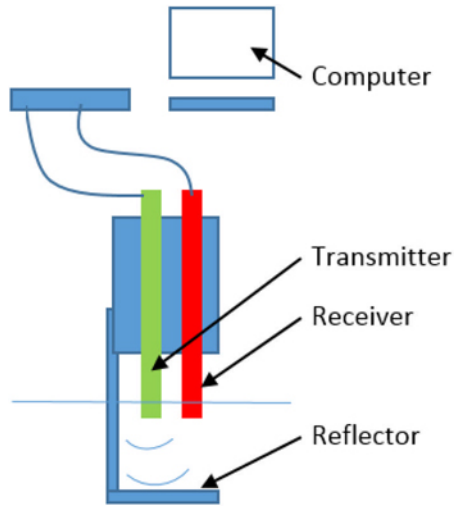

Figure 2: The Main Components of the MetalVision MV20/20 Ultrasonic Inclusion Analyzer.

MetalVision: Imaging or Sonar?

There are various ways to determine if the MetalVision system is an ultrasound imaging or sonar device.

Wavelength Requirements

First, is the wavelength short enough (Hertz high enough) to resolve an inclusion image? The answer was obvious. For inclusion imaging ultrahigh frequency electron beam particles are used and the acoustic waves used in the MetalVision system falls short of the 250 MHz needed for focused inclusion imaging. Therefore, it has to work on sonar principles regardless of the “Vision” in its name. To confirm this statement let us also look at some basic science involved with the MetalVision system:

Pulse frequency: short of 250 MHz (Ultrasonic)
 Sample rate: 100 pulses per second
 Sound velocity in molten Aluminum: 5.89 mm/μs
 Distance between probes and reflector: 4 inches (101.6 mm)

Some basic calculations indicate that each sample pulse travels to the reflector and back in 34.5 μs, considerably less than the next sample pulse delivered at the transmitter (10,000 μs). Therefore, the system works on the principle of sonar, where the reflection (traveling a total of 8 inches) is delivered back to the receiver before the next sample pulse is delivered.

Particle Reflection Mechanism.

The second question is if there is an adequate response (echo) from particles for the transmitter to detect. According to Sprawls³, ultrasound is both reflected and passed through surfaces of sound conducting media. The velocity of the sound wave in a particular media is given by:

$$v = \sqrt{\frac{E}{\rho}} \quad \text{----- (1)}$$

Where: v = Velocity of sound
 E = Young’s modulus or compressibility modulus for the media.
 ρ = Density of the media.

In liquid aluminum this velocity is 5.89 mm/μs and for a typical aluminum oxide particle, it is 9.9 mm/μs.

Reflection from any surface depends on the physical characteristics of the material, in particular its density and Young’s modulus. In acoustics these properties are encapsulated in the impedance, Z , of the material. The impedance equation can be written in terms of the velocity of sound (see equation 1):

$$Z = \rho v \quad \text{----- (2)}$$

Where: ρ = Density of the material
 v = Velocity of sound in the material

The tendency for any surface to reflect some of the acoustic wave is then given by the following equation:

$$\text{Reflection Amplitude (dB)} = 20 \log_{10} \frac{(Z_2 - Z_1)}{(Z_2 + Z_1)} \quad \text{----- (3)}$$

Where: Z_1 = Impedance of material 1 (example liquid Al)
 Z_2 = Impedance of material 2 (example Al₂O₃)

Decibels (dB) are a unit of comparison that give relative amplitudes of acoustic waves according to the following equation:

$$\text{Relative amplitude (dB)} = 20 \log_{10} \frac{A_2}{A_1} \quad \text{----- (4)}$$

A drop in amplitude of 1 dB, therefore, represents a drop of 11% in actual acoustic wave amplitude. Using equation 3, the reflectivity of aluminum oxide can be calculated as -5.49 dB, which means that approximately 47% of the amplitude is reflected and 53% continues through the alumina. By increasing the amplitude, the reflection of particles would therefore become visible. (See the mechanism explained in Figure 3.)

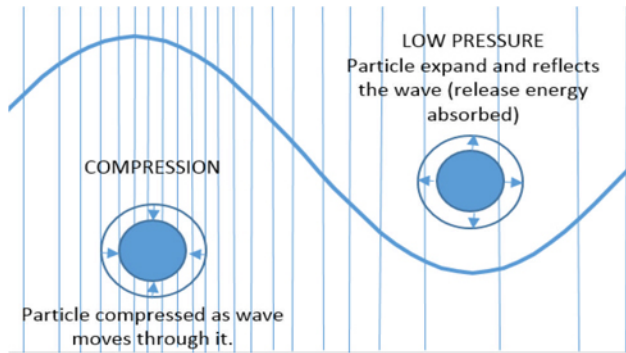

Figure 3: Acoustic Wave and Particle Interaction.

From the analysis in Figure 3 it follows that the “spring back” after a pressure wave is related to the Young’s modulus and the source of the amplitude reflection.

MetalVision: Attenuation

The conclusion from the discussion of the theory behind the MetalVision MV 20/20 is therefore that the system works as a sonar device and does not generate an image of inclusions but instead measures size based on the intensity or amplitude of reflections received back from different sized particles.

Another feature of the MetalVision system is the ability to measure total attenuation of the signal reflected from the mirror. According to Sprawles³, attenuation of sound waves are given by:

$$\text{Attenuation (dB)} = afx \quad \text{----- (5)}$$

Where: a = attenuation coefficient (dB per cm at 1 MHz)
 f = Frequency (Hz)
 x = Distance traveled

In the MetalVision system, x can be adjusted in the software according to the system assembly. As the frequency is fixed in the MHz range, the only unknown is “ a ”. The MV20/20 system was calibrated against five nines (99.999%) purity aluminum and therefore, the attenuation measured by the system calculates a dB loss relative to the pure aluminum and is expressed as a percentage. Higher purity, therefore, has a higher ratio relative to pure aluminum and is expressed as a percentage. This percentage is a valuable feature of the system, as it represents the overall cleanliness or clarity of the metal, inclusive of reflection and scattering by all particles sizes even below the size detection limit of 20 μm .

LiMCA®: Basics

Running a constant current through a small orifice while moving the molten metal to be sampled through the hole enables the detection of changes in voltage across the hole. These voltage spikes can then be analyzed to determine the quantity and size of inclusions (Figure 4).

Electrical Inclusion Detection

The equation for electrical particle detection (as in the LiMCA®) using voltage spikes would be:

$$V = Kr \quad \text{----- (6)}$$

Where: K is a constant current
 r = Resistance across the orifice due to an inclusion passing through.
 V = Voltage spike

The limitations of such a system is immediately evident as the conductivity of the inclusion(s) to be measured now plays a role. The response of a liquid salt with ionic conductivity would be diminished. Furthermore, a small orifice would lead to liquid and gas bubble distortion as it moves through the hole. Solid particles of non-spherical proportions could also present a small or large cross-section, affecting the intensity of the spike (This limitation is also inherent with the MetalVision system).

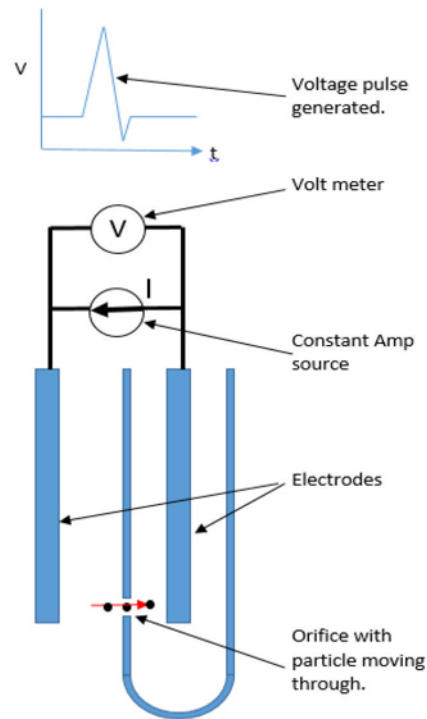

Figure 4. LiMCA® operation principle.

There is also the limitation of a single orifice at a constant depth during the measurement not being a representative sample of the inclusion distribution throughout the metal depth. Sample size is also small (only about 3 grams every minute). Finally, there is the limitation of the complex electronic circuits required to detect and analyze the voltage spikes and also the limitation in measuring particles smaller than 15 microns due to the orifice to inclusion size ratio. Reducing orifice size exposes the orifice to the risk of being blocked by larger particles. The complex electronics also makes the system expensive and often a bit sensitive to production environment conditions.

Table 1: Comparison of Inclusion Detection Systems.

	Method	Real Time	Sample Size	Particle Size Range	All Inclusions?	Alloy Relativity?	Export to Excel?	Portability	Robustness	Cost
Metal-Vision®	Sonar	Yes	Large	20 - 160	Yes (attenuation)	Marginal	Yes	High	High	Medium
LiMCA®	Electric	Semi	Small	15 - 150	No	No	Yes	Low	Low	High
PreFil®	Filtration Rate	Partial	Medium	None	Yes	Yes	Yes	High	Medium	Medium
PoDFA®	Filter Cake	No	Medium	None	Yes	No	No	High	High	Low

Other Non-Continuous Measurements

Beside the continuous MetalVision and semi-continuous LiMCA® systems, PreFil® delivers a filtration rate on a per sample basis, while both PreFil® and PoDFA® produce filter frits with inclusion concentrations that can be analyzed off-line by metallurgical quantography.

Practical Validation of the MetalVision System

Step 1: Offline Crucible Testing and Comparison with PoDFA® Data

The first step in validating the MV20/20 inclusion analyzer was to take PoDFA® samples at various positions within the JW Aluminum molten metal production and casting system, presenting various levels of cleanliness. At the same time as taking the PoDFA® samples, metal was sampled into bread sows and sent to MetalVision for analysis with the MV20/20. The bread sows were re-melted in a crucible and the MV20/20 was inserted into the melt and stabilized. The metal was then stirred while making measurements. Table 2 lists the results.

The MV20/20 software has a programmable feature called the “MV Grade” (red line) that combines the other 4 measurements:

- 1.) Clarity (blue line), as a % of the 99.999% purity aluminum reference.
- 2.) Largest particle (orange line)
- 3.) Mean particle size (brown line) and
- 4.) Particle count

The color coding for the particle size in the screen shots are given in Figure 5 below:

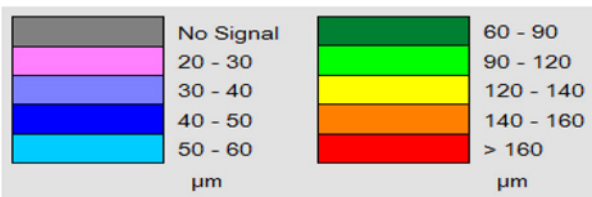

Figure 5: Color Coding for the Samples

Table 2: PoDFA® and MV20/20 comparison

Sample #	1	2	3	4	5
PoDFA® (mm2/kg)	0.062	0.113	0.383	0.461	1.063
Clarity	63%	62%	51%	49%	55%
MV Largest Particle	96	156	155	141	160
Particle Count	76	78	78	68	95
Samples					

From the screen shots, the settling after stirring is evident. Also evident is a broad correlation of the MV20/20 measurements with the PoDFA® data. The MV20/20 result breaks the inclusion measurement down into different parameters that gives a better description of the nature of the inclusions. For example, sample 5 had better clarity than sample 4, which indicated sample 5 had fewer fine particles, but more larger particles than sample 4, even though sample 4 had the lower PoDFA® number.

Step 2: On-Site Testing of the MV 20/20 Inclusion Analyzer

After the initial PoDFA[®] comparison, an on-site demonstration of the MV20/20 capabilities was performed. During the week-long trial, multiple opportunities presented itself for the validation of the MV20/20 analyses (Figure 6).

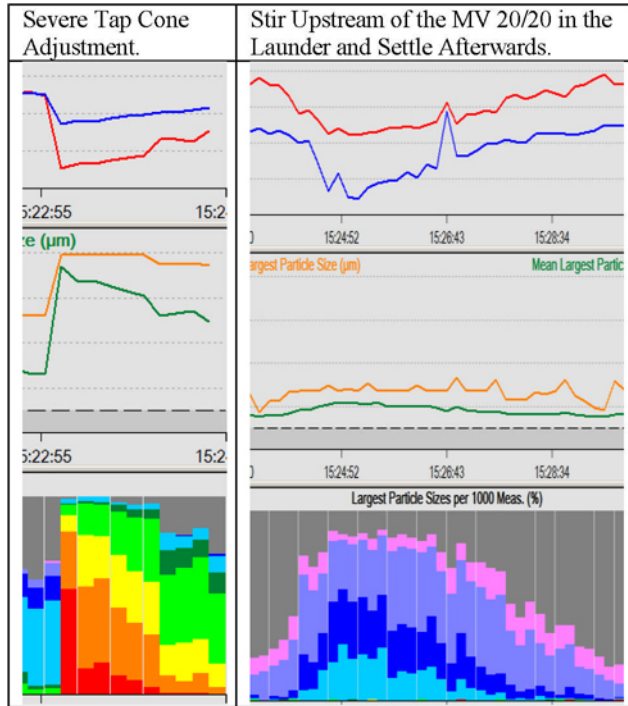

Figure 6: Sample of Opportunities to Validate the MV20/20 Performance.

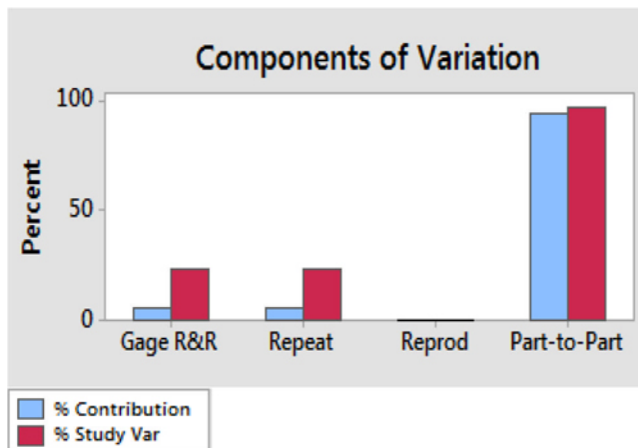

Figure 7: Gage R&R Results Using the Clarity Measurement to Determine the Variability in Measurements from Operator to Operator

Step 3: Reproducibility Testing

Three operators were trained to run the MV 20/20. These three were then used in a destructive sample, nested Gage R&R to determine the reproducibility and variation between operators of the equipment. Figure 7 shows the results. Since the test was run at a launder and therefore the operators were not sampling the same material, a destructive, nested gage R&R was used.

The results from the gage R&R indicate that:

- 1.) Part-to-part variation was high as samples were taken at the Melter, Holder and after filters.
- 2.) The repeatability of an individual operator measuring at the same position was acceptable.
- 3.) The error between different operators measuring in the same position was low (good).
- 4.) The overall gage R&R study variation came in at 23% which is acceptable (below 30%).

Therefore, the MV 20/20 passed the gage R&R and can be used for process improvement.

Further Experience with the MV20/20 System

From experience with the system, the best analogy that can be made as to the functioning of the MV20/20 inclusion analyzer is that it operates like a WWII sonar system. Particle identification is like seeing unfocused dots of light on a screen, the intensity being representative of the size of the inclusions. Because of the system not working as an ultrasound imaging device, the largest unfocused dots completely blot out the smaller dots hidden within their halos. Consequently the system identifies the largest inclusions accurately, but then omits smaller inclusions.

Nevertheless, the clarity number (blue line) makes up for this lack of identification of smaller inclusions. Attenuation or clarity measures all inclusions, down to the smallest, and gathers them all into one number relative to 99.999% purity aluminum.

The system is best described as a comparator that classifies metal quality relative to each other. As such, the system in the delivered condition, lacks the ability to analyze very clean metal, as only the clarity is left to compare. But, it was found that manipulation of the constants in the setup menu enables the system to better compare very clean metal.

The system turned out to be remarkably robust and easy to use, compared to the writer's prior experience with a LiMCA II system. During one trial, the MV20/20 was used continuously for 13 hours under very hot conditions without any failures. The ability to download data into a text file and convert into Excel[®] has proven to be very handy as the data can easily be subjected to statistical analysis and editing. Furthermore, making notes in the software during measuring is a useful feature to remind the operator of events that took place during the trial.

Conclusions

The MetalVision MV20/20 inclusion analyzer is a robust, easy to use, real time inclusion analyzer that delivers consistent and repeatable comparative analyses of inclusions in molten aluminum. The ratio of performance to price made it an obvious choice for JW Aluminum. The unit has been used successfully to improve the metal quality delivered to casting, and therefore has ensured that higher quality products are delivered to JW Aluminum customers.

Acknowledgements

The authors would like to express their gratitude to the management of JW Aluminum for providing the opportunity to test the MetalVision system and showing commitment to inclusion data collection and product quality by purchasing a unit. Also to the casting group at Mount Holly, under leadership of Randy Gibson and Kent Britt for their support during the trials.

References:

1. I.D. Sommerville, M. Kurban, N.D.G. Mountford and P.H. Mountford "An Ultrasonic Sensor for the Continuous Online Monitoring of the Cleanliness of Liquid Aluminum" TMS San Francisco February 2005
2. R. Gallo, P.H. Mountford and I.D. Sommerville "Ultrasound for On-Line Inclusion Detection in Molten Aluminum Alloys: Technology Assessment" Proc. 1st International Conference on Structural Aluminum Castings, Nov 2003, 1-16.
3. N.D.G. Mountford, P.H. Mountford, I.D. Sommerville and B. DeWalle, "An Ultrasonic Sensor for On-Line Monitoring of Liquid Metal Cleanliness" Proc. Gerald Heffernan International Symposium on Innovative Technologies for Steel and Other Materials, Met. Soc. C.I.M., 2001, 227- 240.
4. Olympus Online Tutorial: "What is Ultrasound?" accessed at <http://www.olympus-ims.com/en/ndt-tutorials/flaw-detection/ultrasound/>
5. P. Sprawls, "Ultrasound Production and Interactions," Online Tutorial Accessed at <http://www.sprawls.org/ppmi2/USPRO/>