

Research on Mechanically Activated Digestion Performance of Diasporic Bauxite and Kinetics

LV Guo-zhi¹, ZHANG Ting-an¹, KE Xian-yao¹, ZHAO Ai-chun¹, NI Pei-yuan¹, MU Wang-zhong¹, BAO-Li¹

(Key Laboratory of Ecological Utilization of Multi-metal Intergrown Ores of Ministry of Education, School of Materials and Metallurgy, Northeastern University, Shenyang, Liaoning 110004, China)

(LV Guo-zhi, Lecture, E-mail: lvgz@smm.neu.edu.cn; ZHANG Ting-an, Professor, E-mail: zta2000@163.net)

Keyword: mechanical activation; diasporic bauxite; digestion performance; kinetics

Abstract

This paper proposes a “mechanical activation-homogeneous digestion” technology as a strengthening method for diasporic bauxite digestion process of alumina production. Effects of digestion temperature, digestion time and mechanical activation speed on digestion performance of diasporic bauxite were investigated by using “homogeneous digestion” equipment, and the digestion kinetics of diasporic bauxite was studied as well. The results indicate that the mechanical activation can greatly improve the digestion performance of diasporic bauxite, digest mine with larger particle size. The optimal mechanically activated digestion temperature is 20°C lower than that of direct digestion. The relative digestion rate of alumina goes up to above 97% when digested at 245°C for 60 minutes with a mechanical activation speed of 80rpm. The apparent activation energy of mechanically activated digestion is 57.30kJ/mol, 21.09kJ/mol lower than the direct digestion. The kinetic equation of mechanically activated digestion is $(1-\eta)^{-1/3}-1=1.5532 \times 10^{-4} \exp(4.764 \times 10^5/T)t$.

Introduction

By the end of 2009, the annual output of Chinese alumina product has reached 25.00 million tons, which takes the first place in the world. However, the reserve of high quality bauxite in China is not high although the bauxite resources are abundant. The dominant bauxite in china is diaspore with a high content of aluminum and silica but low content of iron, which is NOT cost effective for alumina refinery. Diaspore requires high digestion temperature and high concentration of caustic alkali, and the

high level of reactive silica causes expensive losses of caustic soda during Bayer processing.

With the growth of aluminum industry in China and the improvement of processing technology, the digestion-strengthening technology of diasporic bauxite is widely concerned by industry and academy. At present there are many intensive leaching methods for diasporic bauxite, such as roasting pretreatment – low temperature leaching technology, mining added sweetening technology, activated digestion technology and so on^[1-6].

This paper focused on the effects of mechanical activation parameters on digestion performance of diasporic bauxite. The digestion kinetics is also studied in this paper to provide theoretical information on this technology for the alumina production.

Experiment

The diasporic bauxite used in this investigation is from Henan Province of China. Its chemical composition is given in Table 1 and Table2. The X-ray diffraction patterns is shown in Fig.1, which was tested by PW3040/60 X-ray diffraction, $2\theta=5^\circ\sim 90^\circ$.

The dominant mineral in the bauxite is diaspore. Some other minor minerals, such as hematite, kaolinite and anatase are also observed in the sample.

The solution used in the experiment is sodium aluminate liquor. The concentrations of total alkali, caustic alkali and Al_2O_3 in the solution are about 239g/L, 221g/L and 125g/L respectively.

Tab.1 Chemical compositions of diaspore samples

Chemical composition	Al ₂ O ₃	SiO ₂	Fe ₂ O ₃	TiO ₂	CaO	MgO	L.O.I
Content/%	60.82	11.07	9.10	2.91	0.55	0.86	8.63

Tab.2 Mineralogical composition of the diaspore samples

Phase composition	diaspore	Kaolinite	hematite	anatase	others
Content/%	>60	18.58	9.10	2.91	2.17

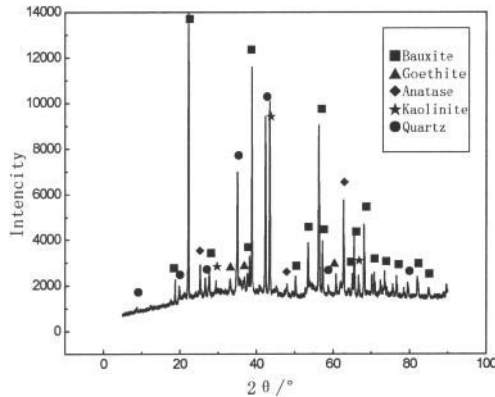

Fig. 1 XRD patterns of bauxite

Mechanically activated digestion experiment

Experiment equipment

The mechanically activated digestion experiments were carried out in the homogeneous autoclave, and the structure diagram of this autoclave was shown in Fig.2.

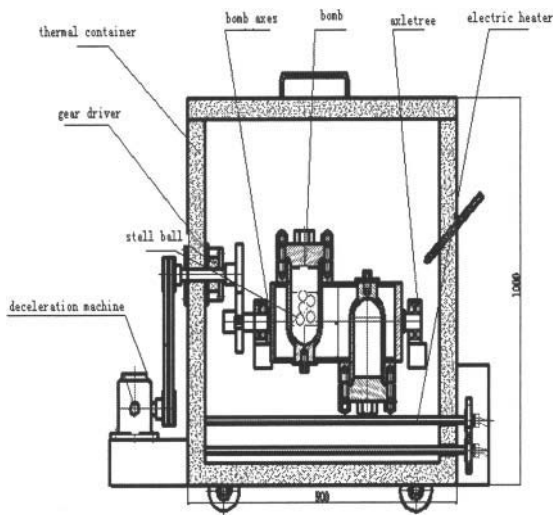

Fig.2 Balanced ball milling reaction kettle

The heating medium is air. The rotation rate is controlled by an electric machine which is adjustable so that we can find the optimal process conditions. The bomb radius is 0.15m.

Bayer process is applied in our experiments. The ore, raw liquid and steel balls (only ore and raw liquid in contrast experiments) were put into the bomb, and then the cover was screwed back to make it airtight. The bomb was put on the axes, and kept in a thermal container with setting digestion temperature. The milling digestion was started by rotating the bomb at a certain rotation speed when it reaches the setting temperature, and hold for a certain time. The bomb was taken out after digestion and cooled in the cold water. The digested

slurry was then filtrated. The concentrations of Al_2O_3 and Na_2O in solution were analyzed and the solid were prepared for XRD analysis. The digestion rate of alumina can be calculated by equation (1).

(1)

$$\eta = \frac{(C_d - C_m)V}{W \times A} \times 100\% \quad \text{where, } \eta\text{-absolute digestion rate of alumina, \%}$$

C_d - Al_2O_3 concentration in digested liquid, g/L; C_m - Al_2O_3 concentration in original liquid, g/L; V - volume of mother liquid, L; W - weight of ore, g; A - the percentage of Al_2O_3 in raw ore, %.

The caustic ratio of digested liquid was calculated by equation (2).

(2)

$$\alpha_K = 1.645 \times \frac{Na_2O}{Al_2O_3}$$

Results and discussions

Effects of the rotation speed of mechanical activation on the digestion efficiency

To obtain the optimal rotation speed, the digestion efficiency of diasporic bauxite and the caustic ratio at different rotate speed were studied, and the digestion conditions are set as follows: digestion temperature of 245°C, ratio of ball to bauxite of 30%, lime addition of 5%, digestion time of 45mins, liquid solid ratio of 5 and the maximum diameter of the balls is 20cm. The digestion result is shown in Table 3.

Table 3 shows that the rotating speed affects the alumina digestion efficiency significantly. The alumina leaching efficiency is improved obviously with the increasing of rotating speed when it is lower than 80rpm. But the leaching efficiency decreases as the rotate speed is above 100rpm. This can be explained by the ball mill grinding principle: The effect of ball mill grinding depends on the motion state of the ball and materials, and the motion state depends on the rotate speed.

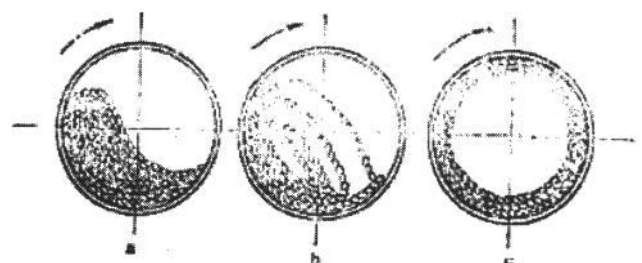

Fig.3 Different moving stats of balls in the mill

Rotary speed/rpm	60	80	100	120	140
$N_k/g \cdot L^{-1}$	173.24	191.56	203.44	207.40	214.83
Composition of digested liquid					
$Al_2O_3/g/L$	154.94	244.15	195.18	196.69	161.81
α_k	1.8394	1.2907	1.7146	1.7346	2.1839
Digestion rate of $Al_2O_3/\%$	47.57	77.16	73.51	63.32	48.70

The balls in the mill have three different moving states:

(1) When the mill is at a low rotating speed, steel balls and slurry go up and form a slope, then slide down along the slope. So crushing function mainly relies on friction between balls and mill;

(2) When the mill rotates at higher speed, balls are moving in a centrifugal way. They can go up to a higher position, and then fall down due to the gravity, which is called parabola drop(Fig.3-b), so crushing function mainly rely on impulsion produced by balls when they drop. At this circumstance, milling effects are the best.

(3) When the mill rotates at a very high speed, the centrifugal forces of most balls exceed the gravity and the balls move with the bomb at the same pace. As a result, the ball could not mill the ore at all. This speed was defined as critical speed. (Fig.3-c).

Theoretical critical speed of ball mill can be calculated by equation (3) (Proposed by Phischer, 1904):

$$n_c = \frac{42.4}{\sqrt{D}} \quad (3)$$

The bomb radius used in this experiment is about 0.15m, so the critical speed of ball mill is about 100rpm. According to an experiential equation, the ball speed and critical speed has the following relation: $n_w = (0.75\sim 0.95) n_p$. At this speed a large number of balls move in the way of parabola type, resulting in the best broken and mixing results^[7-13].

Effects of the particle size of mine mechanically activated on the digestion efficiency

The efficiency of direct digestion and mechanically activated digestion with different mine size were also studied in this paper. The digestion conditions utilized are: digestion temperature of 245°C, ratio of ball to bauxite of 30%, rotating speed of 80rpm, lime addition of 5% and digestion time of 30mins. The digestion result is shown in table 4.

Table 4 shows that the alumina digestion efficiency is improved with the decrease of particle size of mine. The absolute digestion rate of alumina is about 25% for direct digestion of mine with an average particle size of -0.25mm. While the rate for mechanical activated mine with same particle size is increased significantly to ~57%, and the rate for mine with particle size of -0.71mm is already higher than 30%.

Particle sizes of raw ore/mm	Direct digestion	Mechanically activated digestion				
	-0.25	-1.00	-0.71	-0.50	-0.42	-0.25
Composition of digested liquid						
$N_k/g \cdot L^{-1}$	214.83	197.01	203.44	205.42	204.43	201.46
$Al_2O_3/g/L$	136.15	147.56	156.44	162.98	168.85	179.08
α_k	2.396	2.196	2.139	2.073	1.992	1.851
Digestion rate of $Al_2O_3/\%$	25.49	29.90	33.78	38.90	44.74	57.07

Effects of the digestion temperature and time on the digestion efficiency

The effect of digestion temperature and time on the digestion performance for direct digestion and mechanically activated digestion were also investigated in this paper. The ratio of ball

to bauxite, the lime loading and the rotating speed were kept the same as before, but the digestion temperature and digestion time were varied between 215°C-245°C and 0-120min, respectively. The digestion results are shown in Fig.4.

Figure 4 showed that mechanical activation could significantly improve the digestion performance of diaporic

bauxite. The absolute digestion rate of alumina is 69.71% (relative digestion rate of 85.22%) for direct digestion after digesting at 245°C for 75min, while the mechanically activated digestion can get the same rate only need digest at 230°C for 60min. The optimum absolute digestion rate is above 79%

(relative digestion rate is 96.9% when digested at 245°C for 60min with a mechanical activation rotating speed of 80rpm. In addition, at the same digestion time of 50min, the optimal mechanically activated digestion temperature is 20°C lower than that of direct digestion.

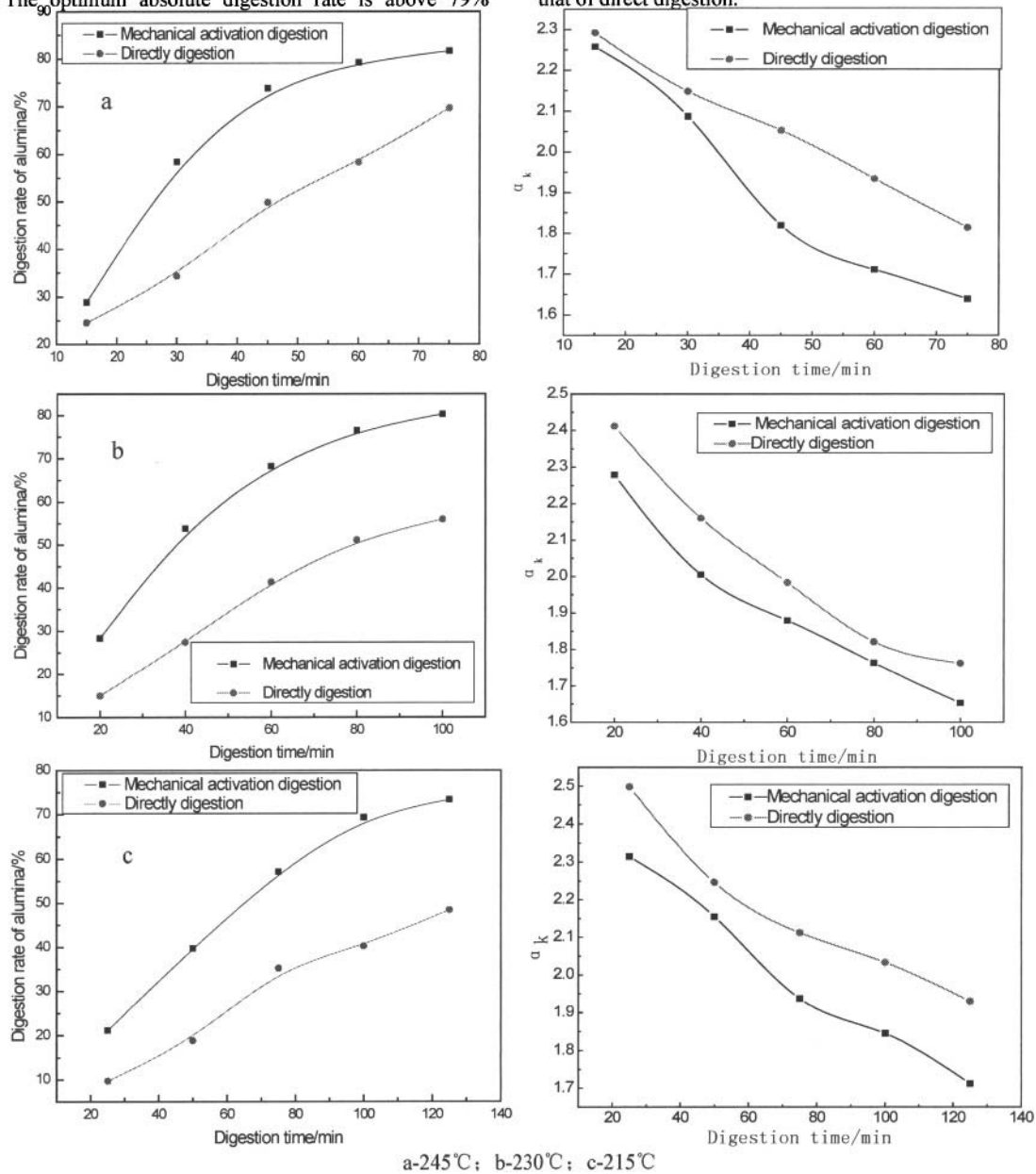

Fig.4 Effects of digestion temperatures and digestion time on digestion efficiency

Research on the kinetics of digestion

This paper derives the kinetics model of diaspor digestion process based on the following assumption:

- (1) The digestion reaction mainly occurred on the surface and around the porous area of the mine particles, without the formation of solid product layer during digestion process.

Particle radius gradually shrinks with the reaction, and bauxite surface area S is a first-degree function of particle radius r , which is $S = \varphi r$, where φ is a constant. The digestion process is a first-order reaction;

(2) $[OH^-]$ in solution can be expressed as: $C=C_0(1-\beta\eta)$,

where β is the coefficient related with the solution, and η is the

digestion rate of alumina. Only free [OH⁻] affects the digestion process.

The kinetics model of digestion process is described as [14-16]:

$$-\frac{dGa}{dt} = KSC = K\varphi C_0(1 - \beta\eta) \quad (3)$$

Ga-amount of substance of AlOOH, mol; C₀ - concentration of free [OH⁻] in digestion liquid before reaction, g/L; C - concentration of free [OH⁻] in digestion liquid after reaction, g/L; K-reaction rate constant; t-reaction time, min. $\eta=1-r^3/r_0^3$; so:

$$\frac{d\eta}{dt} = -\left(\frac{3r^2}{3r_0^2}\right) \cdot \left(\frac{dr}{dt}\right) \quad (4)$$

After integration, under the condition of t=0, $\eta=0$, we get:

$$(1-\eta)^{-1/3}-1=K't \quad (5)$$

$$K' = \left(\frac{9K\varphi M_a C_0}{4\pi\rho_a r_0^2}\right) \quad (6)$$

The calculated data from the model described above are fit to the digestion experimental data, and the results are shown in Figure 5. It can be seen from the figure that in the range of 215°C -245°C, for bauxite direct digestion and mechanical activation digestion, the relationships between $(1-\eta)^{-1/3}-1$ and time are all linear throughout the range, and the correlation coefficient is more than 99%, indicating that the dynamic equations are consistent with the kinetics of the digestion process. The slope of the straight line for digestion process is the apparent rate constant K' as shown in equation 5. From which, the apparent activation energy values can be calculated by Arrhenius equation ($\ln K' = -E/RT + C$). The calculated results are shown in figure 6, and the results of K' and E were shown in Table 5.

In the temperature range of 215°C -245°C, the kinetic equation of digestion process of diasporite by mechanically activated treatment is:

$$(1-\eta)^{-1/3}-1 = 1.5532 \times 10^{-4} \exp\left(\frac{4.764 \times 10^5}{T}\right)t \quad (7)$$

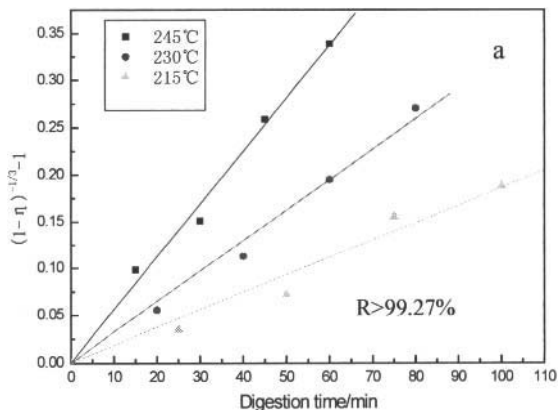

a) direct digestion

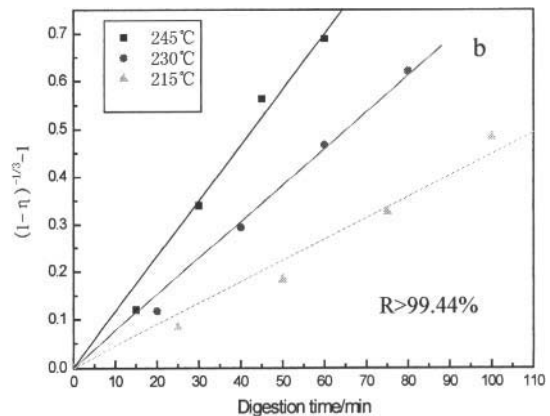

b) mechanically activated digestion

Fig.5 Liners fitting of $(1-\eta)^{-1/3}-1$ on time t

Table 5 K' at different temperature and kinetic energy E				
	K' / min ⁻¹			E /kJ·mol ⁻¹
	245 °C	230 °C	215 °C	
Direct digestion	0.006510	0.003239	0.002127	78.39
Mechanically activated digestion	0.01069	0.007526	0.004719	57.30

Conclusion

(1) The mechanical activation can significantly improve the digestion performance of diasporite bauxite, and also broaden the particle size range of mine digested. The optimal mechanically activated digestion temperature is 20°C lower than that of direct digestion when both digested for 50min.

(2) The ball-milling mechanically broke the diasporite bauxite particles during the digestion, which created new reactive interfaces and improved the digestion kinetics continually. The mixing effect of ball-milling made the Al(OH)₄⁻ diffuse away from the reaction interface, reducing the concentration of aluminate anions in the reaction area, thus further improving the digestion process.

(3) The optimum absolute digestion rate of alumina goes up to above 79% (relative digestion rate is 96.90%), when digested at 245°C for 60min with a mechanical activation speed of 80rpm.

(4) The apparent activation energy of mechanically activated digestion is 57.30kJ/mol (215°C -245°C), 21.09kJ/mol lower than the direct digestion. The kinetic equation of mechanically activated digestion is

$$(1-\eta)^{-1/3}-1=1.5532 \times 10^{-4} \exp(4.764 \times 10^5/T)t.$$

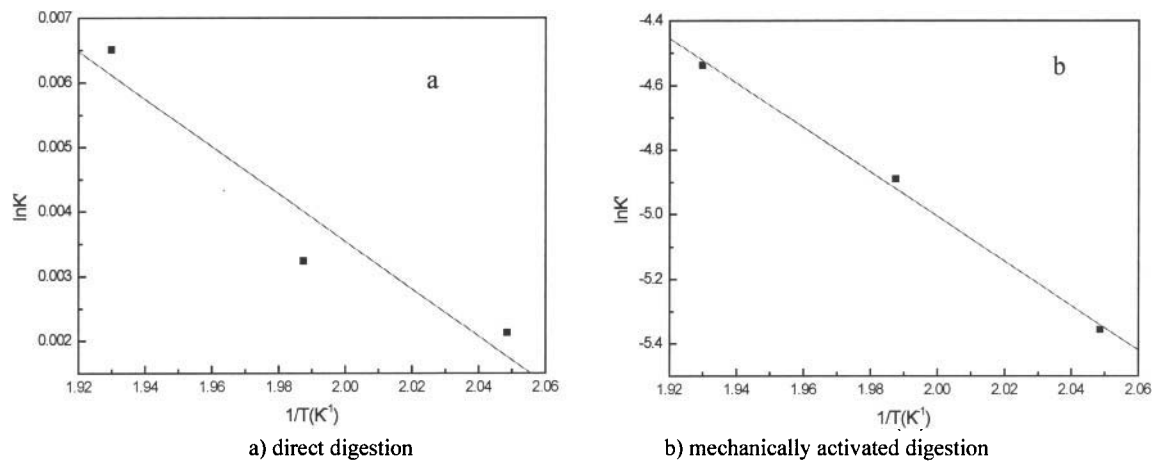

Fig.6 Liners fitting of $\ln K$ to $1/T$

Acknowledgement

This research was supported by the National Natural Science Foundation of China (NO. 51004033)

Reference

- [1] ZHAO Qing jie. New technics on research of diasporic digestion[J], *Light Metals*, 2000,(1): 17~21.
- [2] YANG Chong Yu .Alumina production technics (revised edition)[M], BEI JING: Metallurgy industry publishing company,1993,23~31.
- [3] LI Wen Hua, ZHAO Pei Sheng, WANG Hong. Approach of intensified bayer process on diasporic digestion[C]. Corpus of the fourth civil light metals metallurgy academy (QING DAO), 2001:128~130.
- [4] Pawlek F. The Leaching Behavior of bauxite during Mechanical Chemical Treatment[J], *Light Metals*,1992,(2): 91~95.
- [5] M Al-Harashseh. Microwave-assisted leaching-a review[J], *Hydrometallurgy*, (3~4)2004, 73.
- [6] CHEN Wankun, and PENG Guancai. Intensified Digestion Technology of Bauxite[M], BEI JING: China Metallurgy Industry Press, 1998, 112-116.
- [7] CHEN Zhen-hua, CHEN Ding. Mechanical alloying and solid-liquid reaction milling[M], BEI JING: Chemical industry press,2005,6~231.
- [8] P. Bala'z'. Mechanical activation in hydrometallurgy[J]. *Hydrometallurgy*, 2002,65:83~85.
- [9] CHEN Shi Huan. Mechanical activation and its application in hydrometallurgy[J], *Shanghai nonferrous metals*,1998,(2): 91~97.
- [10] LI Yun Jiao, LI Hong Gui. Discussion on application of mechanical activation in hydrometallurgy[J], *Rare metal and horniness alloy*,1993,(1):39~41.
- [11] CHEN Zhen Hua, CHEN Ding. Mechanical alloying and ball milling reaction between solid and liquid [M], BEI JING: chemistry industry publishing company,2006,1.
- [12] Barnabás Csöke, Zoltán Hatvani. Investigation of grindability of diasporic bauxites in dry, aqueous and alkaline media as well as after high pressure crushing[J], *International Journal of Mineral Processing*, (4)2004:123~125.
- [13] XIAO Zhong liang, ZHAN Xue hui, SHI Yan, et al. The effect of mechanically activated stored energy of sphalerite on the dissolution reaction kinetics[J], *Industrial Minerals and Processing*, (4)38,2009, 19~21.
- [14] LI Xiao Bin. Roasting process on bauxite and digestion kinetics of roasted bauxite[D], CHANG SHA: *Industry University of Mid-south*, 1985.
- [15] LI Xiao Bin, ZHOU Qiu Sheng, PENG Zhi Hong, et al. Study on the kinetics of digesting roasted diasporic in the sweetening process[J], *Journal of Central South University of Technology*, 2000, 31(3):219-221.
- [16] H. Babaki, A. Salemand A. Jafarizad. Kinetic model for the isothermal activation of bentonite by sulfuric acid[J], *Materials Chemistry and Physics*, 2003,108: 263~268.