

## CASE 13

# Parameter Design of Ceramic Oscillation Circuits

**Abstract:** In this study, parameters were designed using an orthogonal array to maintain stable oscillation even if the temperature and voltage vary.

## 1. Introduction

Oscillating frequency, accuracy, and oscillator type are different depending on usage. In general, as compared with a crystal oscillator, a ceramic oscillator tends to be used for a circuit that does not require less accuracy because of its lower price and accuracy (Figure 1). In this study we designed parameters to maintain stable oscillation even if the temperature and voltage vary.

## 2. Factorial Effects and Optimal Configuration

After selecting seven factors as control factors and two factors as error factors assigned to an outer array, we define their levels as shown in Table 1. Each factor was allocated to an  $L_{18}$  orthogonal array. After we implemented each of the 18 experiments assigned to the inner array under the nine conditions assigned to the outer array, we obtained oscillating frequency data as measured characteristics. In quality engineering it is recommended that a generic function be used. But at the time this experiment was conducted, the nominal-the-best characteristic was frequently used. In data development in quality engineering, the use of frequency was suggested for oscillating circuits. On the basis of these data, we computed SN ratios and sensitivities.

Variation of general mean:

$$S_m = \frac{\left(\sum_j y_{ij}\right)^2}{9} \quad (f = 1) \quad (1)$$

Error variation:

$$S_e = \sum_j y_{ij}^2 - S_m \quad (f = 8) \quad (2)$$

Error variance:

$$V_e = \frac{S_e}{8} \quad (3)$$

$$\eta = 10 \log \frac{S_m - V_e}{V_e} \quad (4)$$

$$S = 10 \log S_m \quad (5)$$

Figure 2 depicts SN ratios and sensitivities of effective factors.

Although we calculated a constant by choosing a combination of levels to attain the maximum SN ratio, the eventual frequency fell below the target value. Thus, by adjusting it with the factors affecting sensitivity, we determined the optimal configuration.

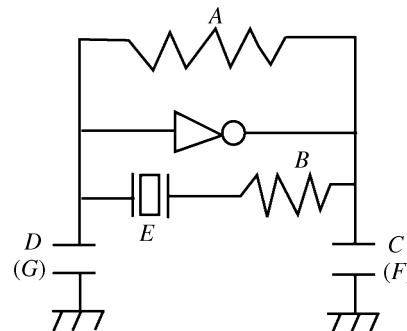

**Figure 1**  
Ceramic oscillation circuit

**Table 1**  
Factors and levels

Factor	Level		
	1	2	3
Control factors			
A: resistance	200 kΩ	1 MΩ	4.7 MΩ
B: resistance	100 Ω	1 kΩ	10 kΩ
C: capacitance (C) (pF)	33	100	330
D: capacitance (D) (pF)	33	100	330
E: manufacturer of oscillator	M	N	K
F: grade of capacitor (C)	Temperature compensating	Generic	—
G: grade of capacitor (D)	Temperature compensating	Generic	—
Noise factors			
H: environmental temperature (°C)	0	25	50
I: voltage of power source (V)	-12	-15	-18

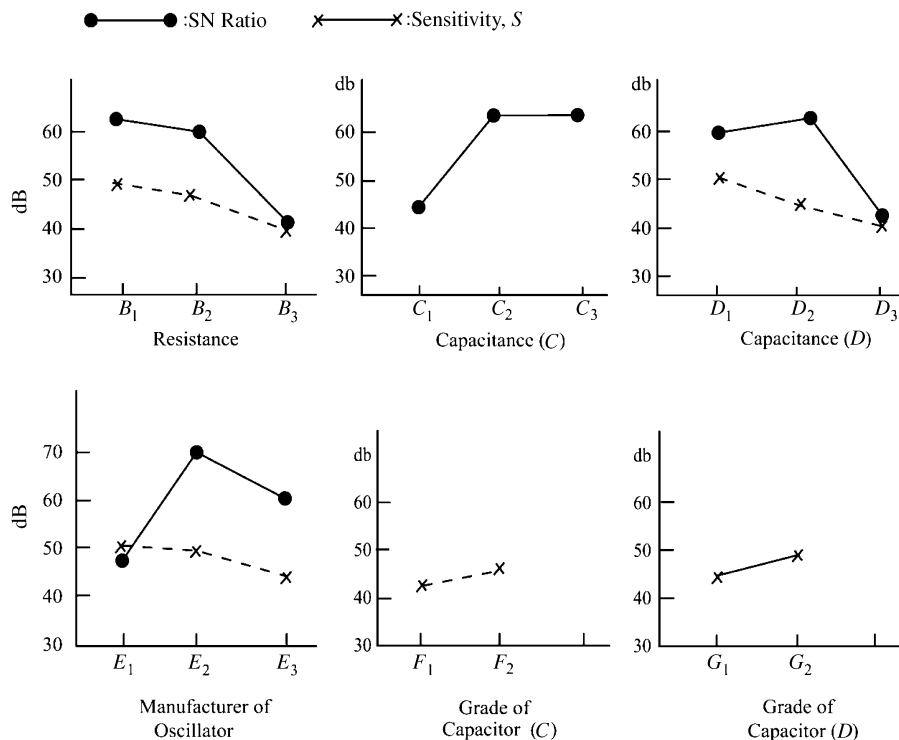

**Figure 2**  
SN ratios and sensitivities of effective factors

**Table 2**  
Confirmatory experiment result at optimal configuration (kHz)

Sample	0°C			25°C			50°C		
	-12 V	-15 V	-18 V	-12 V	-15 V	-18 V	-12 V	-15 V	-18 V
1	100.05	100.04	100.03	100.10	100.09	100.08	100.10	100.09	100.09
2	99.83	99.82	99.82	99.85	99.84	99.83	99.89	99.88	99.88

- A:  $A_1 = 220 \Omega$       B:  $B_1 = 100 \Omega$   
 C:  $C_3 = 330 \text{ pF}$       D:  $D_1 = 33 \text{ pF}$   
 E:  $E_2 = N$               F:  $F_2 = \text{generic}$   
 G:  $G_2 = \text{generic}$

### 3. Confirmatory Experiment

Based on the optimal configuration, we implemented a confirmatory experiment. Table 2 shows the result. We note that even if the power source's voltage and environmental temperature vary, the oscillation can remain stable. We obtained an optimal circuit successfully. In addition, we verified that the circuit could achieve good oscillation in the confirmatory experiment.

The following are  $\eta$  and  $S$  values for the confirmatory experiment:

Sample	$\eta$ (dB)	$S$ (dB)
1	80.80	49.55
2	80.04	49.53

We analyzed a measured characteristic as nominal-the-best. However, as a reference, by regarding it as a deviation from the target value of 100 kHz and using equations (6) and (7), we reanalyzed it according to the smaller-the-better procedure.

$$V_e = \frac{\sum_j (x_{ij} - 100)^2}{9} \quad (6)$$

$$\eta = -10 \log V_e \quad (7)$$

In both cases we found that  $B_1 D_1 E_2$  is optimal.

### Reference

Kiyohiro Inoue and Genichi Taguchi, 1984. *Reliability Design Case Studies for New Product Development*, pp. 169–173. Tokyo: Japanese Standards Association.

*This case study is contributed by Kiyohiro Inoue.*