

Chapter 18

Builders' Quantities

18.1 Lift pit

Figure 18.1a–d shows the plans and cross sections for a lift pit which is part of a proposed new school. The project is to be procured on a design and build basis, and builders' quantities are needed to price this particular item of work. On-screen measurement from a PDF file will be employed to prepare the builders' quantities using the Buildsoft Cubit non-SMM-based software.

18.1.1 Take-off list

Having imported PDF drawings into the Buildsoft Cubit Viewport, it is good practice to prepare a take-off list which can then be entered into the Estimate sheet of the software. Once this has been done, quantities can be prepared.

The take-off list and the quantities will be quite different from the equivalent for an NRM2 take-off and will reflect the estimator's view of site practicalities and how the work will be carried out:

- **Excavation:**
 - The pad foundation for the lift pit is a complex shape and will, in all likelihood, be excavated as a rectangle.
 - There will, therefore, be additional excavation, disposal and backfilling compared to the 'net' measurement required by NRM2.
 - Site excavations never resemble the clean lines on the drawing, and there will inevitably be some 'overbreak' leading to an even greater volume of dig, disposal and backfill. Bearing in mind the depth of the excavation (over 2.5 m), earthwork support would be needed for safety reasons; this is not a measurable item under NRM2 (unless specified).
 - The estimator might feel that a 'battered' excavation would be more practical; this would lead to extra excavation, disposal, concrete and backfill.
- **Concrete to lift base:**
 - As the concrete pad foundation is un-reinforced mass concrete, NRM2 would describe the item as being *poured on or against earth or unblinded hardcore* (11.1.1.3.1), with no formwork measured; the estimator would thus need to consider:
 - The need for some rough shuttering (formwork).
 - Making an allowance for additional concrete to fill the excavation.
 - Whether some rough shuttering would avoid a lot of wasted concrete; if so, some working space would be needed which is not measurable under NRM2.

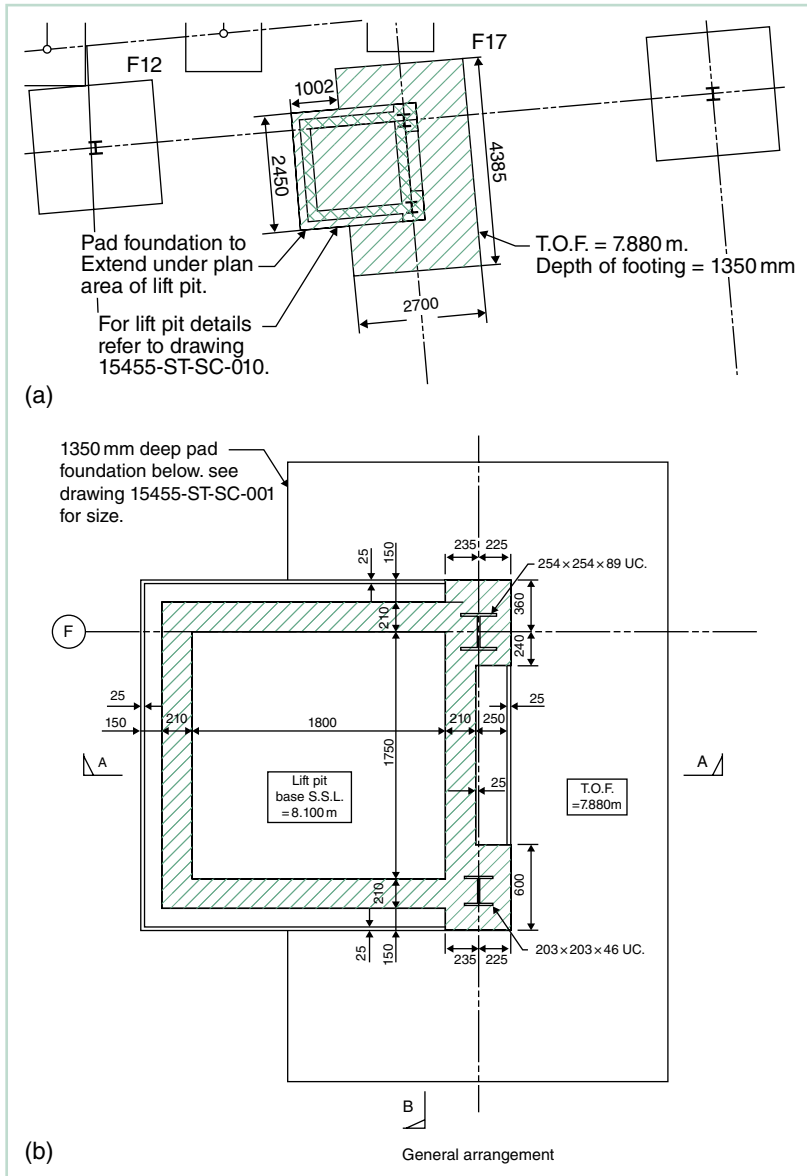

Figure 18.1 Lift Pit. (a) Plan – 1. (b) Plan – 2. (c) Section A–A. (d) Section B–B. Reproduced with the kind permission of Ramboll UK Ltd.

- **Concrete to steelwork:**
 - Two steel columns are to be fixed to the pad foundation, and these are to be encased in concrete as an integral part of the lift pit wall; this creates a complex shape for both formwork and concrete.
 - As a result, the estimator may decide that the concrete casing to the columns would be cast first, and the wall formwork and concreting would follow as a subsequent activity.
 - This would mean measuring formwork differently to NRM2 which would measure formwork as an attached column (11.21.1) but only to the outer faces; the inner face would be measured with the wall formwork.

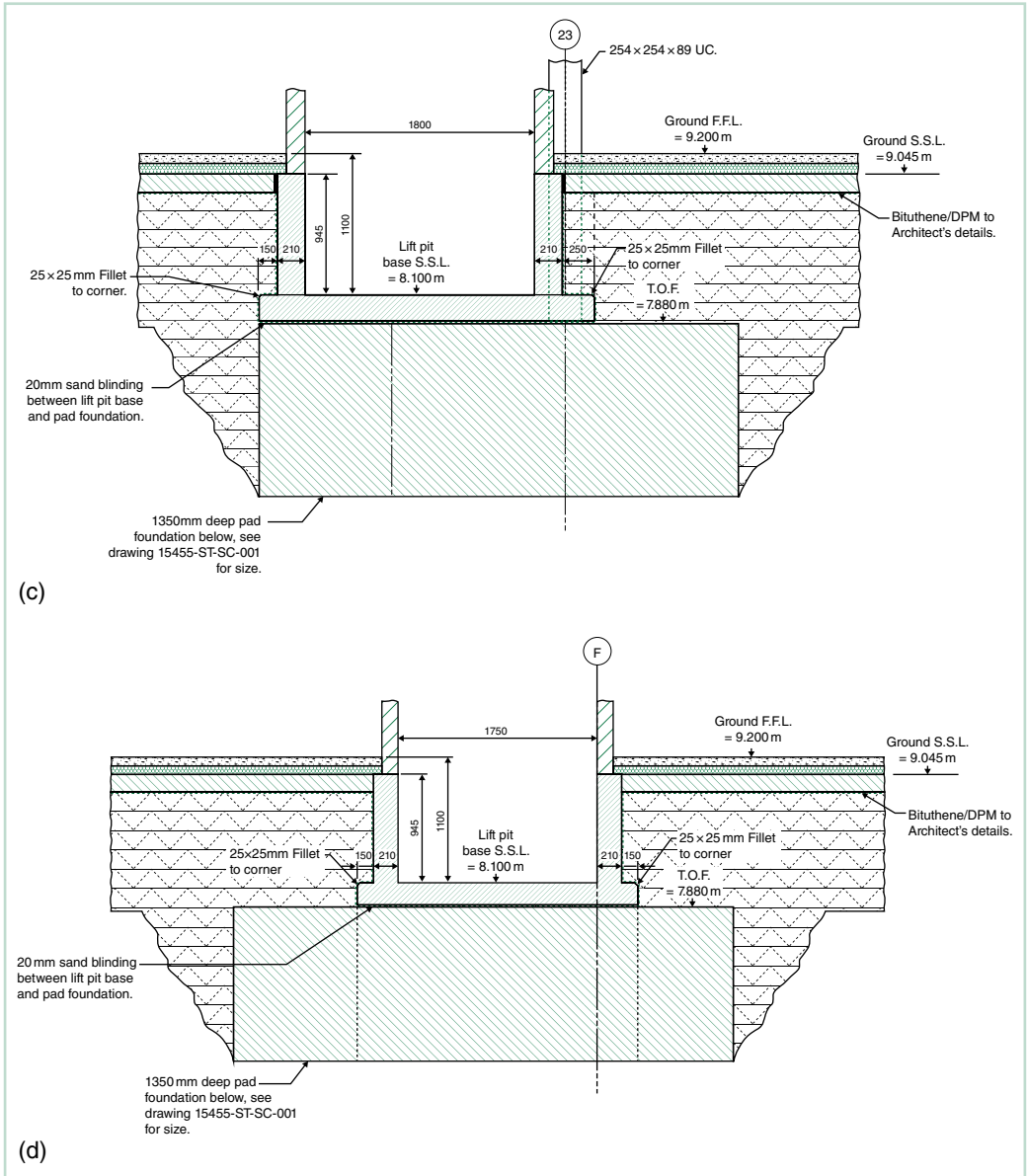

Figure 18.1 (Continued)

Table 18.1 shows the take-off list and compares the NRM2 rules of measurement with how builders' quantities might be approached for the lift pit take-off.

18.1.2 Preparing the quantities

Once the estimator has decided on the preferred take-off approach, the take-off list can be entered into the Buildsoft Cubit software 'Estimate' screen as a list of items to be measured on-screen.

Table 18.1 NRM2 and builders' quantities compared.

Reference	Item	NRM2	Unit	Builders' quantities	Unit
A	Excavate pad foundation	Measured 'net'	m ³	Measured 'gross'	m ³
B	Disposal off-site	Ditto	m ³	Ditto	m ³
C	Working space	Not measured	—	Optional – could be measured or not	m ²
D	Earthwork support	Not measured	—	Should be measured as it will be needed	m ²
E	Mass concrete to lift base	Measured 'net' as plain in situ 'mass' concrete in lift pit base (11.1.1.3.1)	m ³	Measured 'gross'; rough shuttering could be measured instead to limit the amount of waste	m ³
F	Sand blinding	Imported filling (5.12.1.1.1)	m ³	Could be measured or included with base slab	m ²
G	Concrete base slab	Horizontal work ≤ 300 thick (11.2.1.2.2)	m ³	Could be measured in m ³ but m ² might be more practical as the surface finish and sand blinding could be included in the rate	m ²
H	Surface finish	Trowelled finish (11.1.1)	m ²	Could be measured or included with base slab	m ²
I	Formwork	Plain formwork to sides of foundations and bases (11.13.1)	m	Measured	m
J	Wall kickers	Suspended kickers measured on centre line – both sides deemed included (11.32.2)	m	Would not be measured but allowed for in the rate	—
K	Rebar	Measured (but not in this exercise)	t	Measured or an allowance made (but not in this exercise)	t/%
L	Concrete casing to columns	Vertical work > 300 thick in structures (unreinforced) (11.5.2.1)	m ³	Measured	m ³
M	Formwork	Sides of attached columns; regular shape (11.21.1)	m ²	Measured but on all four sides	m ²
N	Concrete to lift base walls	Vertical work ≤ 300 thick in structures (reinforced) (11.5.1.1.2)	m ³	Could be measured in m ³ but could also be measured in m ² so that the estimator could include both concrete and formwork both sides in the rate	m ³ / m ²
O	Formwork	Plain formwork to faces of walls; vertical (11.22.1)	m ²	Could be measured or included with rate for concrete in walls	m ²
P	Rebar	Measured (but not in this exercise)	t	Measured or an allowance made (but not in this exercise)	t/%
Q	Backfill with suitable material	Imported filling in beds > 500 thick but only above void created by the concrete base (5.12.3.1.1)	m ³	Could be measured or included in rate for working space or earthwork support	m ³

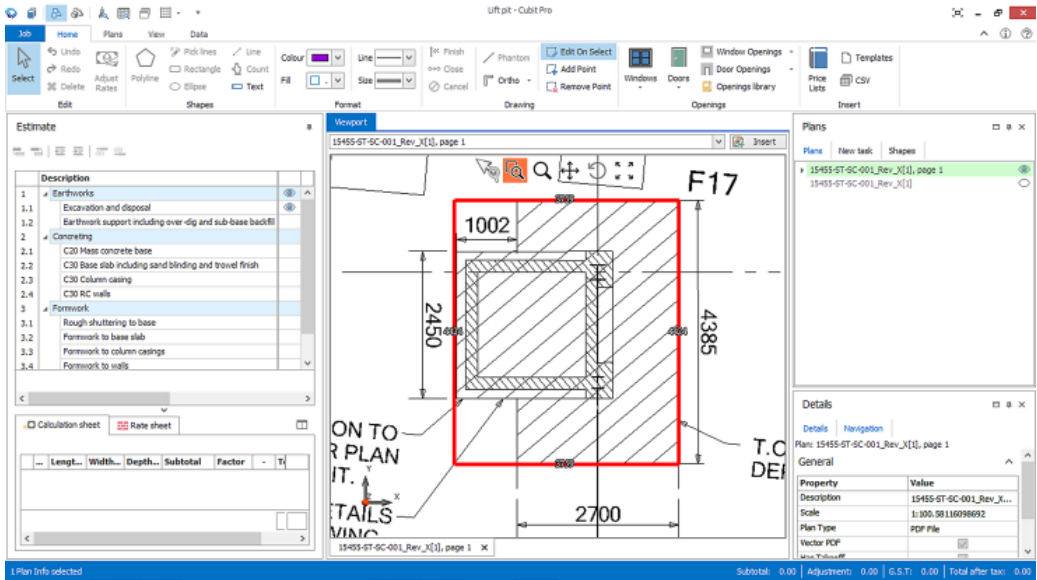

Figure 18.2 Take-off list using Buildsoft Cubit.

This can be seen in Figure 18.2 which shows the take-off list in the Estimate screen and the imported PDF file in the Viewport. Figure 18.2 also shows a rectangle around the lift pit base indicating the limits of the excavations to be measured as opposed to the ‘net’ dimensions shown on the drawing. The waste calculation for the depth of excavation is calculated as follows:

Ground level	9.045	
Less		
Top of foundation slab	<u>7.880</u>	
	1.165	
Add		
Foundation thickness	<u>1.350</u>	2.515

Following on-screen measurement of the lift pit using Buildsoft Cubit, a completed take-off can be exported into Excel, and edited as required, as shown in Table 18.2.

18.1.3 Quantities comparison

It makes an interesting contrast to compare the builders’ quantities take-off with the equivalent using NRM2.

Table 18.3 has been prepared with CATO, according to the NRM2 rules of measurement, and it is immediately obvious that there are 13 measured items compared to only 10 in Table 18.2. Numerically, there is very little difference, but extrapolated for a complete bill of quantities, there would be 30% more items in the NRM2 take-off than the builders’ quantities. It goes without saying that the item descriptions are much more extensive in the NRM2 take-off (Table 18.3).

Some of the quantities vary quite a bit, but this is largely explained by the fact that the builders’ quantities have been taken off as the estimator sees the work being done operationally, and not *net as fixed in position* in accordance with NRM2 Paragraph 3.3.2(1)(a) requirements.

Table 18.2 Builders' quantities for lift pit.

Take-off for lift pit				
Description	Quantity	Unit	Rate	Total
Earthworks				
Excavation and disposal	40	m ³		
Earthwork support including over-dig and sub-base backfill	40	m ²		
Total for Earthworks				
Concreting				
C20 Mass concrete base	22	m ³		
C30 Base slab including sand blinding and trowel finish	6	m ²		
C30 Column casing	1	m ³		
C30 RC walls	2	m ³		
Total for Concreting				
Formwork				
Rough shuttering to base	22	m ²		
Formwork to base slab	10	m		
Formwork to column casings	4	m ²		
Formwork to walls	8	m ²		
Total for Formwork				
Total				

18.1.4 Software

Guidance on getting started with Buildsoft Cubit may be found at http://www.youtube.com/watch?v=Ek3rxdX_D14 which explains how to:

- Set up projects (e.g. school) and jobs within projects (e.g. lift pit).
- Enter items and simple descriptions.
- Enter and manipulate dimensions.
- Import PDF files and scaling.
- Carry out on-screen measurement.
- Etc.

For guidance using CATO, visit Tim Cook's excellent YouTube channel at <http://www.youtube.com/watch?v=ur2jcPw6Ag>.

Table 18.3 NRM2 bill of quantities for lift pit (CATO).

<u>Lift Pit Base</u>				
Page 1				£ p
<u>5 EXCAVATING AND FILLING</u>				
<u>Excavation</u>				
Foundation excavation				
A	over 2 m not exceeding 4 m deep	36	m3	
<u>Disposal</u>				
Excavated material off site				
B	generally	36	m3	
<u>Imported filling</u>				
C	Sand blinding; 20 thick; Level	1	m3	
D	Granular sub-base; Beds exceeding 500 thick	2	m3	
<u>11 IN SITU CONCRETE WORKS</u>				
<u>Plain in situ concrete: grade C20</u>				
Mass concrete				
E	in Lift pit base; poured on or against earth or unblinded hardcore	19	m3	
<u>Plain in situ concrete: grade C30</u>				
Vertical work				
F	exceeding 300 thick; In structures; Column casings	1	m3	
<u>Reinforced in situ concrete: grade C30</u>				
Horizontal work; in base slab				
G	not exceeding 300 thick; reinforced over 5%	1	m3	
Vertical work; in structures; walls				
H	not exceeding 300 thick; reinforced over 5%	1	m3	
<u>Surface finishes to in situ concrete</u>				
Trowelling				
I	to top surfaces	6	m2	
Page 2				£ p
<u>Formwork; plain</u>				
Sides of attached columns				
A	regular; rectangular	3	m2	
Faces of walls and other vertical work				
B	vertical	13	m2	
Sides of foundations and bases				
C	200 high	10	m	
Wall kickers				
D	suspended	10	m	