

## TWIN ROLL CASTING OF ALUMINIUM:

## The Twin Roll Casting Process

## THE OCCURRENCE OF STRUCTURE INHOMOGENEITIES AND DEFECTS IN AS CAST STRIP

General aspects

H. Westengen

Årdal og Sunndal Verk a.s. Metallurgical Research Laboratories

N-6600 Sunndalsøra, Norway

K. Nes

Årdal og Sunndal Verk a.s.

N-5875 Øvre Årdal, Norway

Continuous strip casting provides an attractive shortcut from the liquid metal to final gauge sheet. Twin roll casters are by far the most widespread machines in commercial operation, mainly due to their flexibility and relatively low investment costs. Strip produced by these casters is presently appreciated as a well suited alternative to conventional material for a number of applications, and in some instances improved properties are obtained (1). Twin roll casters have been in commercial operation for nearly three decades, however, the literature on the subject is rather incomplete. Most of the available information has been published by the machine producers, hence attention is mainly paid to the positive aspects of the methods. However, some interesting papers have recently been published. A general description of casting and annealing structures is given by Nes and Slevolden (2), while Jin et. al. (3) consider the formation of centreline segregates during casting. Althoff (1) summarizes some aspects of mechanical properties, and a couple of papers describe new alloys which are especially suitable for strip casting (4,5). A contribution to the understanding of the influence of casting parameters on the solidification zone is presented by Iricibar and Jin (6).

In the present paper a survey of some typical structural inhomogeneities and casting defects occurring during twin roll casting will be given. While most of the defects can be eliminated through careful control of casting conditions and operational practice, it will be evident that in order to become fully competitive with conventional materials for critical applications, further research to upgrade the twin roll casting process will be necessary.

Although differing in some important details, the main principles of machine design and operation are common to the commercially available twin roll casters (7,8,9). Liquid metal from the caster furnace is fed through a launder system to the headbox in front of the casting nozzle, which distributes the metal to be solidified in the gap of the water cooled rolls over the desired strip width. Grain refining elements are added in the casting furnace and/or in the launder. An in-line melt cleaning unit may be installed in the launder system to remove nonmetallic inclusions and gases. Recently built equipment usually includes a coiler with a powerful drive to secure tight coiling and reduce problems caused by sticking of the strip to the roll surfaces.

Solidification front

A schematic drawing of the rolls cavity showing the solidifying strip is shown in fig. 1. Some important parameters are defined in the figure.

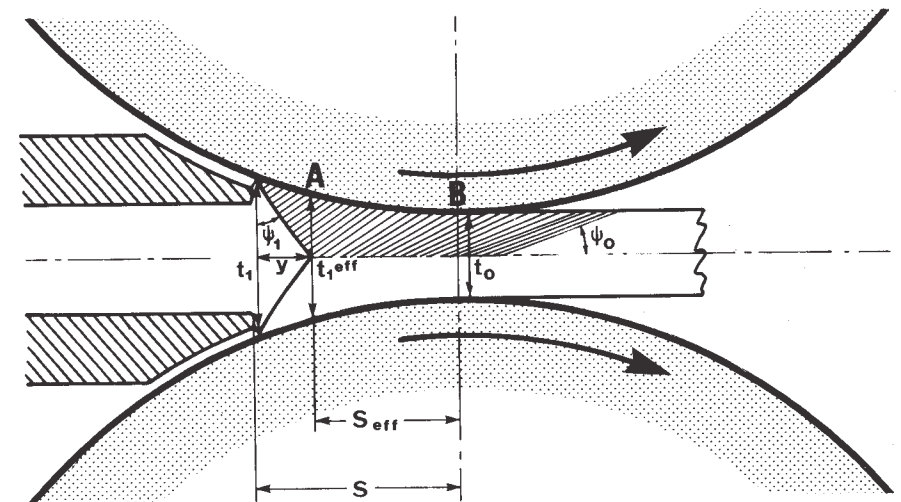

Figure 1 - Schematic drawing showing the rolls cavity, nozzle and solidifying strip.

The typical grain structure of as cast strip, as seen in a longitudinal cross section, fig. 2, contains some information regarding the solidification front. It is assumed that the grains grow normal to the solidification front, and that deformation is essentially confined to the region between A and B in fig. 1. From geometrical considerations the following relationships apply:

$$y = (t_1/2) \tan \psi_1 \quad (1)$$

$$S_{eff} \sim S - y \quad (2)$$

$$t_1^{eff} = S_{eff}^2/R + t_0 \quad (3)$$

$$\tan \psi_1 = (t_1^{eff}/t_0)^2 \tan \psi_0 \quad (4)$$

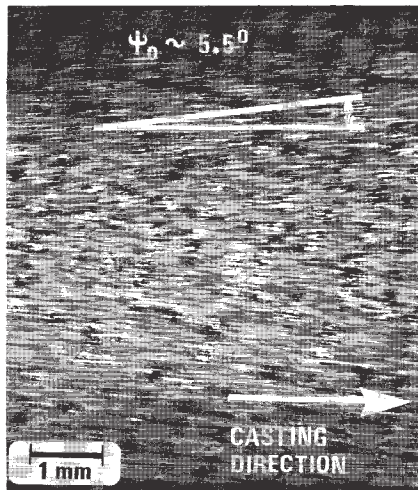

Figure 2 - Typical grain structure of properly grain refined strip. Casting conditions: tip setback S=70 mm, casting speed . 95 m/min., liquid metal temperature in the headbox 685-688°C.

These equations can easily be solved by an iteration procedure allowing the sump length y to be evaluated. For the particular example in fig. 2,  $\psi_0$  is measured to be approximately 5.5 deg corresponding to a sump length y = 4.8 mm.

The influence of roll velocity or casting temperature on the sump length can be deduced from measurements of the forward slip, as demonstrated by Iricibar and Jin (6). As an example, they estimated an increase in the sump length of magnitude 1.6 mm when the roll velocity was increased from 780 to 1260 mm/min., other parameters kept constant.

Deformation in the rolling gap

The reduction in cross section is given approximately by the expression (ref. fig. 1.):

$$\% \text{ red.} = (t_1^{eff} - t_0)/t_1^{eff} \quad (5)$$

For the particular example discussed above this amounts to approximately 58 %. The metal leaves the rolls with a temperature typically around 300°C. Deformation thus takes place in the temperature range between the

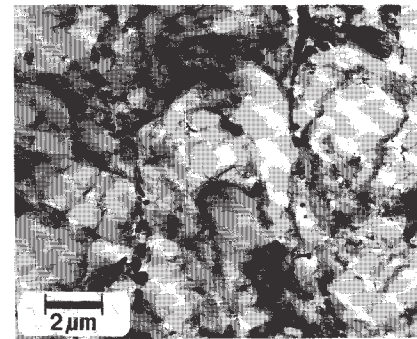
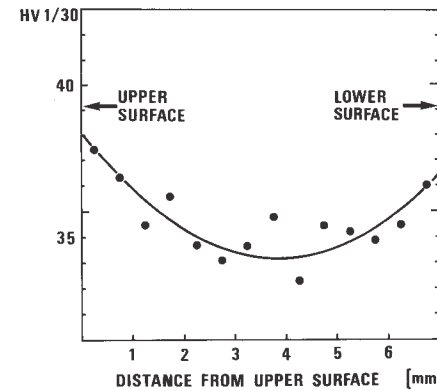
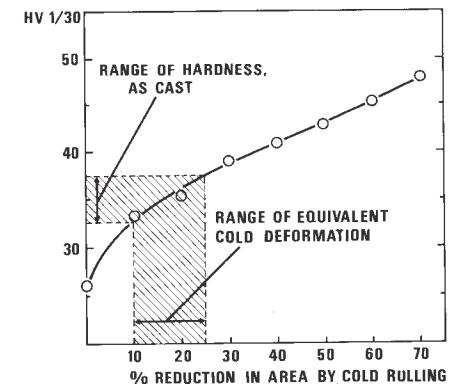

Figure 3 - TEM micrograph showing the deformation structure of as cast strip.

solidus temperature and 300°C. The fairly low exit temperature prevents recrystallization leaving the strip in a deformed condition, fig. 3. Fig. 4a shows the hardness profile across the sheet thickness. When compared with the work hardening curve fig 4b, it follows that the deformation introduced during casting corresponds to 10-25 % reduction in area by cold rolling.



a)



b)

Figure 4 - a: Variation in hardness across the strip thickness, for as cast strip. Al-99.5 wt%. b: Work hardening of the same material during cold rolling after soft annealing.

Solidification microstructure

Solidification occur at high cooling rates, favouring a cellular growth pattern, fig. 5a. The variation in the intercellular spacing across the strip thickness is shown in fig 5b.

By using a formula originally deduced from measurements of secondary dendrite spacing  $d$  and solidification rate  $v$  (10):

$$d \cdot v^{0.33} = 33.4 (\mu\text{m(K/s)})^{0.33} \quad (6)$$

the solidification rate is estimated to be in the range  $10^2$  K/s to  $10^3$  K/s. These values are typically 2 orders of magnitude larger than those of conventional DC-casting (10). The high solidification rate has important consequences for the as cast microstructure:

Size distribution of primary constituents. The small cell size, fig. 5b, directly influences the size of the primary constituents. Compared with conventionally DC-cast and hot rolled material the size of the inter-metallic particles are typically reduced by a factor of approximately 5. This is demonstrated in fig. 6.

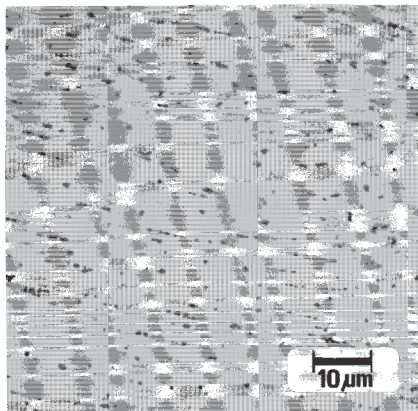

a)

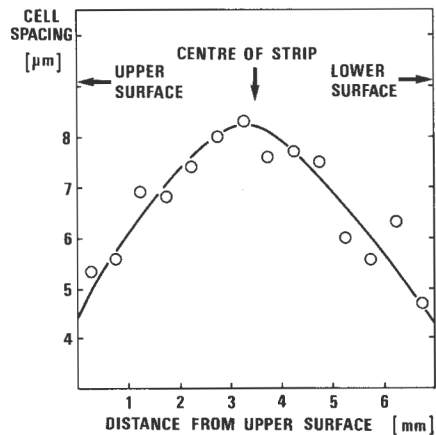

b)

Figure 5 - a: Typical solidification cell structure as observed by light microscopy, longitudinal cross section, .5 mm from the surface. b: Variation in cell spacing across the strip thickness. Alloy Al-.5 wt%Fe-.2 wt%Si.

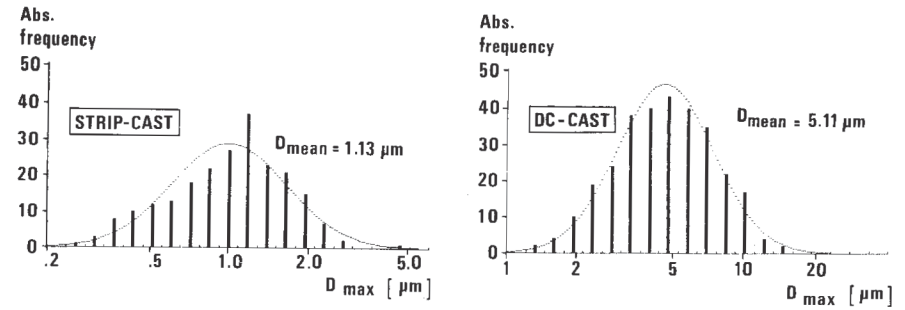

a)

b)

Figure 6 - Size distributions of primary constituents. Alloy AA 3004. a: Strip cast, homogenized 24h/550°C, cold rolled to 2.5 mm and softannealed. b: DC-cast, homogenized, hot and warm rolled to 2.5 mm followed by softannealing. (The quoted mean values are the arithmetic means).

The reduced particle size has some important positive and negative consequences:

The newly developed alloys AA 8006 and AA 8007 utilize a fine dispersion of intermetallic particles to stabilize a grain size in the range 1-5μm. These so-called low-eutectic alloys, show enhanced strength without a severe loss of formability, due to grain boundary hardening. To obtain the necessary dispersion level, a high cooling rate must be applied during casting, favouring the twin roll casting method (4).

Surface galling is frequently observed when cans are produced from strip cast material by the drawing and wall-ironing method. This phenomenon is believed to be caused by the small size of intermetallic constituents, however, other factors related to the as cast surface probably also have an effect.

Types of primary constituents. The high solidification rate favours the formation of metastable compounds during casting. Similar phenomena are observed in DC-cast ingots where the variation in solidification rate across the ingot thickness causes the formation of a number of different phases, giving rise to the so-called "fir-tree" zones (11). The tetragonal phase  $Al_mFe$  which forms at cooling rates exceeding 10 K/s (10) is a dominating phase, together with the bcc  $\alpha-AlFeSi$ , the formation of which is also reported to be favoured by high cooling rates (12).

Elements in solid solution. As-cast strip shows considerable supersaturation of elements like Mn, Fe, Cr, Zr etc. when these are present in the material. As a particular example, the electrical resistivity of an as-cast AA 3004 alloy, containing 1.0 wt% Mg, 1.0 wt% Mn, .13 wt% Si and .35 wt% Fe was measured to be  $6.54 \mu\Omega \text{ cm}^{-1}$ . The amount of Mn + Fe in solid solution is approximately given by:

$$\text{wt\% (Mn + Fe) in solid solution} \sim (\rho - \rho_{\text{Al } 99.99} - 0.5 C_{\text{Mg}})/3.6 \quad (7)$$

where  $\rho$  is the resistivity of the alloy,  $\rho_{\text{Al } 99.99}$  is the resistivity of Al (99.99 wt%) and  $C_{\text{Mg}}$  is the concentration of Mg. The factors 0.5 and 3.6 are taken from ref. (13). They represent the contribution from Mg and Mn in solid solution to the resistivity in units  $\mu\Omega (\text{cm wt\%})^{-1}$ . From the measured electrical resistivity of as-cast AA 3004 it follows that 0.92 wt% Mn + Fe is in solid solution.

Due to precipitation of Mn and Fe during subsequent anneals, grain size problems are encountered (2). Possible means to avoid these problems include homogenizing and flash-annealing. A positive aspect of the high supersaturation is that recrystallization is retarded, giving possibilities for the production of temper-annealed sheet with attractive mechanical properties (1).

Structure Inhomogeneities and Casting Defects

Centreline segregates

Centreline segregates are frequently observed, especially for materials with higher alloy contents, fig. 7. In a recent report by Jin et.al. (3) these inhomogeneities are attributed to pressure-induced channel segregation. Under the action of the pressure exerted by the rolls, liquid metal enriched in alloying elements is squeezed from colder to hotter regions forming channels. When this liquid solidifies, typical eutectic colonies are formed. Locally the composition may even become hypereutectic, causing large preeutectic particles to form, fig. 7. According to Jin et.al. (3), the volume fraction of centreline segregates increases with alloying additions and casting speed. These inhomogeneities seem to be inherent to the roll casting process. No harmful effects have been observed on the final properties of the sheet.

Grain structure

It is a general experience that a fairly large amount of grain refining additions must be applied to secure a homogeneous, fine-grained structure. Figs. 2 and 8 show various grain structures including a properly grain refined structure, fig. 2, feather crystal formation caused by too little grain refiner, fig. 8a, and coarse grains formed when no grain refiners are added, fig. 8b.

Practical experience indicates that a combination of Ti-containing hardener added in the casting furnace and Al5Ti1B-rod added in the launder provide the best reliability during long term continuous running of the machines.

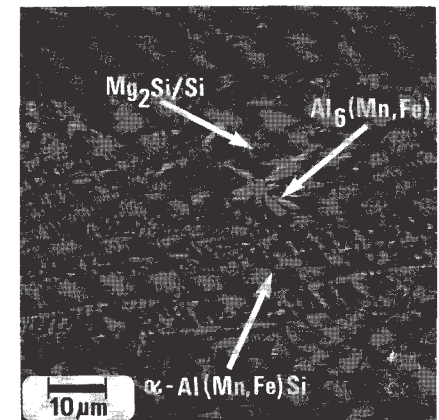

Figure 7 - Centreline segregates as observed by scanning electron microscopy. Alloy AA 3004.

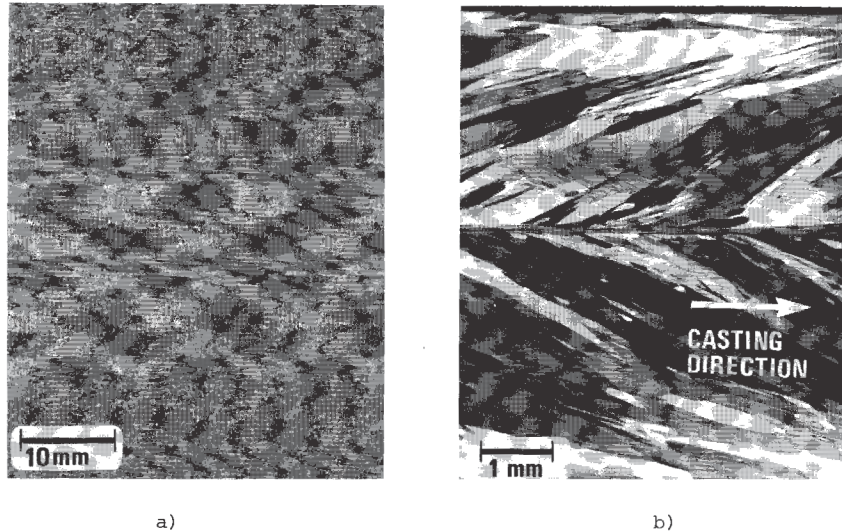

Figure 8 - Unfavourable grain structures. a: Feather crystal formation. b: Coarse grain structure.

Level lines

A surface inhomogeneity termed level lines in analogy with DC-casting is shown in fig. 9. As discussed by Nes (2) this inhomogeneity, which is visible on the as cast sheet, is connected to a subsurface variation in the cell spacing, indicating that the solidification rate close to the surface varies in a periodic way. This is attributed to a cyclic breaking up of the oxide film enveloping the liquid metal when it leaves the tip of the nozzle.

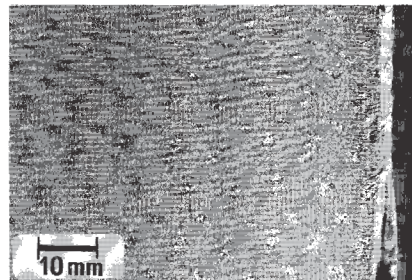

Figure 9 - Typical level lines. The Sample is etched to emphasize the effect.

Surface streaking

Streaks on the surface are often observed during casting. These may or may not be an indication of subsurface defects.

Streaks with underlying voids. A serious casting defect is the formation of more or less continuous stringers of voids, which can extend for hundreds of meters along the strip. Fig. 10a shows an example as seen in a transverse cross section. The occurrence of these defects is more frequent in Mg-containing alloys than in pure aluminium or Al-Mn alloys. The defects are usually accompanied by surface streaking of the as cast strip, fig. 10b.

A simple bend test provides some information on the seriousness of the defects, fig. 10c. It follows from fig. 10a that the grain structure in the vicinity of the voids is distorted, indicating that some restriction to metal flow causes the defect formation.

There are two alternative explanations for the formation of the restrictions:

- Local build up of impurities and clogging of the nozzle.
- Formation of gas bubbles ( $H_2$ ) at the outlet of the nozzle.

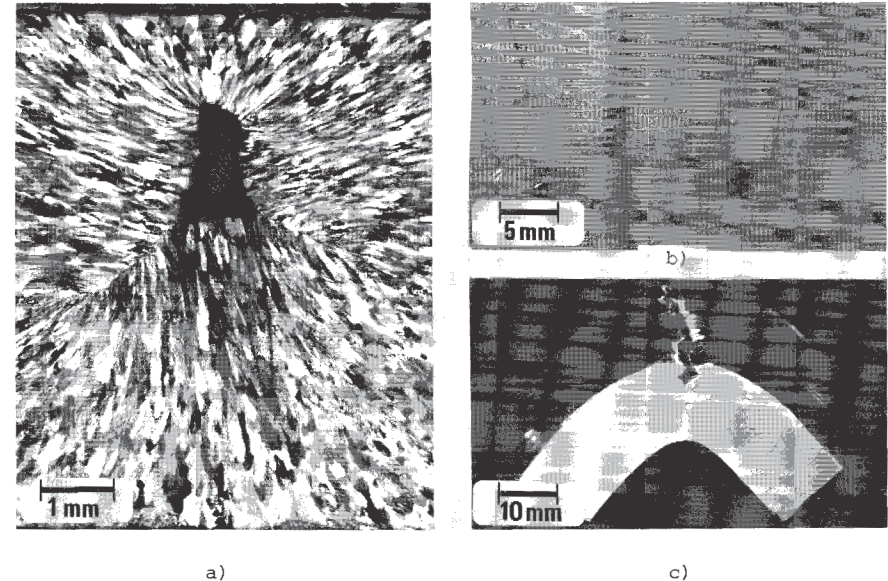

Figure 10 - Surface streaking with underlying voids. a: Transverse cross section showing the grain structure and void. b: Appearance of the as cast surface. c: Cracking after bend testing. Alloy Al - 0.6 wt%Mg - 1.0 wt%Mn.

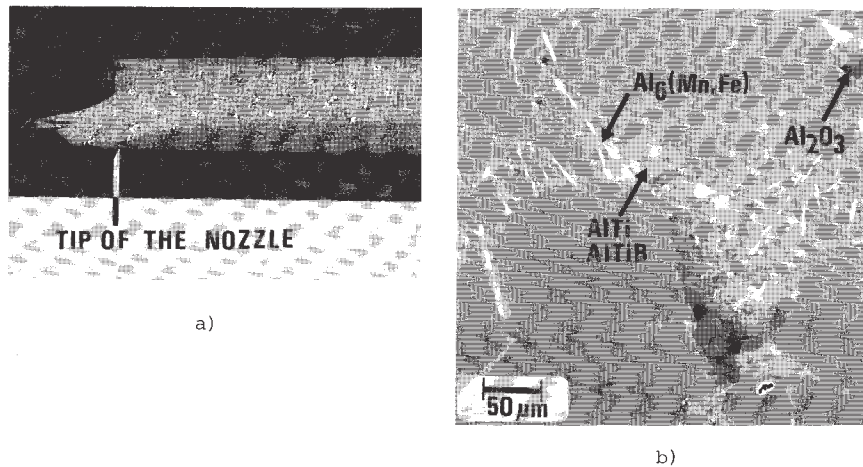

Figure 11 - a: Longitudinal cross section of the material inside the casting nozzle. Etched to reveal the segregates at the bottom of the nozzle. b: Micrograph of the bottom layer showing the various constituents which are present. Alloy Al - 0.6 wt%Mg - 1.0 wt%Mn.

Investigations of the casting nozzle after finishing a casting cycle have revealed build-ups of a slurry at the bottom of the nozzle, fig. 11. Detailed examinations in the scanning electron microscope show agglomerates of Ti and B-containing particles as well as oxides, fig. 11b.

It is also found that Mg-containing melts attack the styrite material in the nozzle leading to erosion and formation of spinels. The more or less stationary bottom layer in the nozzle can become several mm thick and possibly cause local clogging.

Measurements of the H<sub>2</sub>-content in materials containing void defects generally show high values. As an example, the material containing the defect in fig. 10, was found to contain 0.29 ppm H<sub>2</sub>. The low metal throughput necessitates keeping a high temperature in the casting furnace, thus increasing the H<sub>2</sub>-content, especially for Mg containing melts. The need for improved launder systems and efficient degassing units is evident.

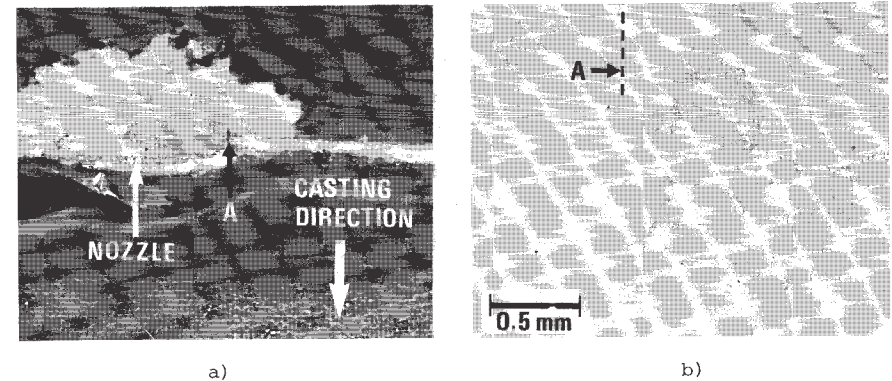

Figure 12 - a: Close up view of the remnants of the tip of the nozzle showing displacement of two adjacent nozzle segments. b: Segregation of Fe/Si caused by the distorted metal flow.

Surface streaks caused by segregates. Any irregularities in the way metal is fed to the solidification zone can cause segregation. Fig. 12a shows a close-up view of the remnants of the nozzle tip after a casting cycle. It is evident that the two adjacent nozzle segments have been displaced, see position A. The resulting distortion of the solidification zone causes surface streaking on the strip. The micrograph in fig. 12b shows massive segregation associated with the streaking.

Unharmful streaks. Finally, to add to the complexity, surface streaks may occur, which are not connected to any internal defects. These disappear during cold rolling and is caused by local variations in the surface condition of the casting rolls, deposits of Al or oxides etc.

Surface defects caused by damaged roll surfaces.

Irregularities in the surface of the casting rolls will be transmitted to the strip surface. The most common damage to the rolls is caused by thermal fatigue. After a certain operation period, the surface of the rolls cracks and protrusions are formed along the edge of the cracks. Accordingly, intrusions are formed in the strip surface which eventually becomes so serious that the rolls have to be reground. Fig. 13a shows the nearly perfect satin matte surface obtainable with newly ground rolls. This can be compared with fig. 13b showing the surface prior to changing the rolls (after casting 450 metric tonnes for this particular example).

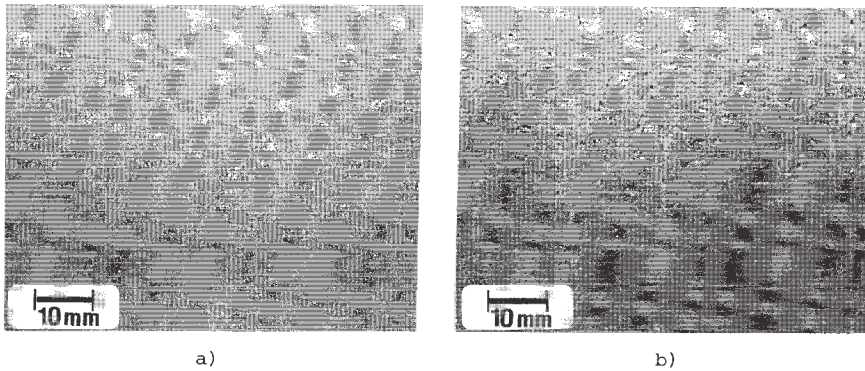

Figure 13 - Typical examples of good and bad strip surface caused by changes in the surface quality of the rolls. a: New rolls. b: After casting 450 metric tonnes.

Rolled-in particles from the nozzle material

In the SCAL Jumbo 3C Caster, the nozzle is fitted by running the rolls in contact with the nozzle tip prior to casting. The clearance between the

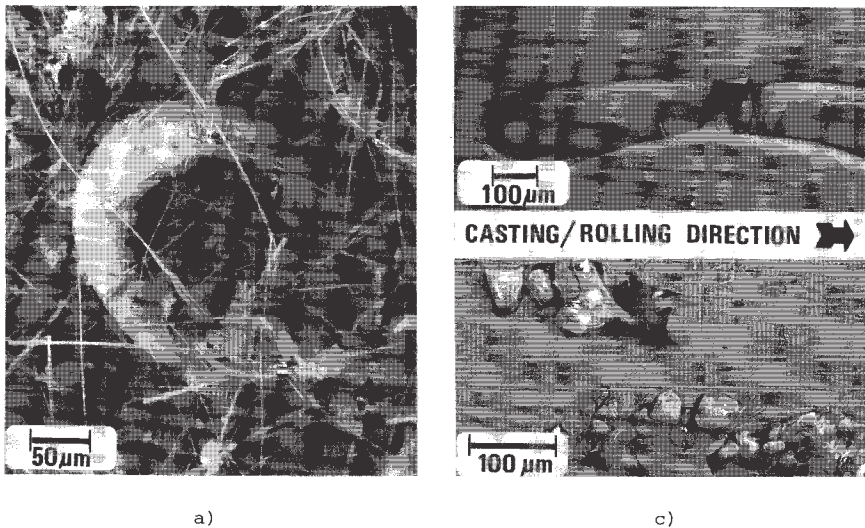
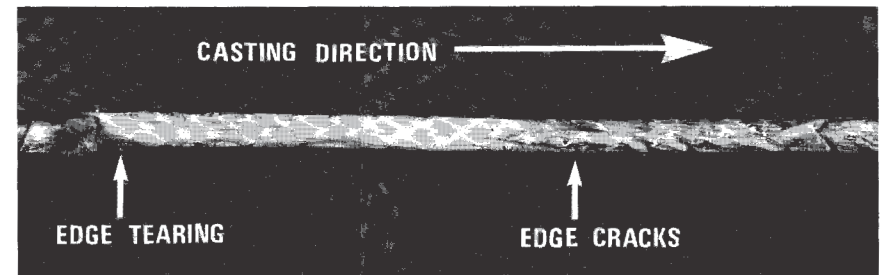

Figure 14 - SEM-micrographs, a: Nozzle material, note the coarse particle embedded in the fibrous matrix. b: Particle from the nozzle rolled into the surface of as cast strip. c: Defects in 70 µm foil caused by the nozzle particles.

nozzle and the rolls during casting is very small and under unfavourable circumstances direct contact can occur. The nozzle material consists of  $Al_2O_3$ - $SiO_2$  fibers with an added binder, however, a coarse fraction of particles is also present, fig. 14a.

When the rolls are in direct contact with the nozzle, particles can be deposited on the roll surfaces and further transmitted to the as cast strip where they are rolled in during the deformation, fig. 14b. During further rolling these particles will cause serious defects in the sheet, fig. 14c. Careful adjustment of the nozzle minimizes the number of these defects, however, improvements in the nozzle material is imperative for complete elimination of the problems.



a)

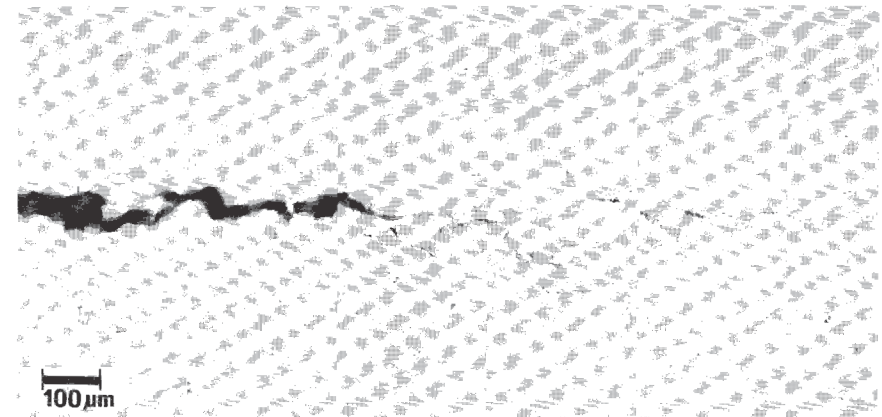

b)

Figure 15 - a: Typical edge cracks which develop into an edge tearing. b: Segregation pattern in the vicinity of an edge crack.

Edge cracking and tearing

Edge cracking is a common feature of twin roll cast material. The cracks can be seen in fig. 15a and more detailed examination reveals a segregation pattern in the vicinity of the cracks, indicating that they are formed when the metal is partly solidified, fig. 15b. Alloys with a large solidification interval are more prone to edge cracking than low alloyed materials. Furthermore, increasing the tip setback favours crack formation due to the heavier deformation. No simple method to eliminate edge cracks is known, except, of course, on-line edge trimming.

Moderate edge cracking can be taken account of by proper dimensioning of the strip width. However, the cracks occasionally develop into edge tearings, fig. 15a. These can extend several cm into the strip and cause dimensional problems during further fabricating.

Sticking

An upper limit to the casting speed is obviously determined by the rate of heat extraction from the melt through the roll walls. Solidification becomes unstable when the metal does not completely solidify prior to leaving the rolls. However, in practice, other speed limiting phenomena occur, in particular that of adhesion or sticking of the strip to the roll surfaces. The sticking tendency increases with roll velocity and temperature of the liquid metal. Furthermore, alloys with a wide solidification range are more susceptible to sticking than others. The sticking problems can be reduced by using efficient lubricants (MgO, graphite) and applying tension to the strip. According to Bercovici (14), macroscopic sticking, which can cause serious strip damage is preceded by microsticking which can be detected by comparing the driving forces on each of the rolls. This phenomenon has been used in the design of an automated control system to optimize productivity (14), however, such systems are not in common use.

Concluding Remarks

The present summary of structure inhomogeneities and casting defects is far from complete. It does, however, indicate the variety of phenomena that needs attention. To the metallurgist, the continuous strip casting process presents new and interesting tasks. Furthermore, problems related

to the equipment emphasize the need for further developments by the machine designers and production engineers. The most acute problems are related to the feeding of liquid metal to the solidification zone. Improvement of the nozzle material is imperative. With regard to the economy of the process, improved life-time of the rolls is important. A basic understanding of edge cracking and sticking could substantially contribute to a reduction of the scrap percentage and increase productivity of the process.

Acknowledgements

The authors are grateful to Årdal og Sunndal Verk a.s. for permission to publish this paper, as well as to the staff of the Research Laboratory for their assistance with experimental work.

References

1. J. Althoff, "Einfluss der Wärmebehandlung auf die mechanischen Eigenschaften von bandgegossenem Aluminiumhalbzung", *Aluminium* 56 (3) (1980) pp. 199-202.
2. E. Nes and S. Slevolden, "Casting and Annealing Structures in Strip Cast Aluminium Alloys", *Aluminium* 55 (5) (1979) pp. 319-324.
3. I. Jin, L.R. Morris and J.D. Hunt, "Centreline Segregation in Twin Roll Cast Aluminium Alloy Slab", pp. 873-888 in *Light Metals 1982*, J.E. Andersen, ed.; AIME, New York, N.Y. 1981.
4. L.R. Morris, "Structure of Continuously Cast Eutectics Used in the Manufacture of Fine-Grained Aluminium Sheet", pp. 370-376 in *Solidification of Metals*, The Iron and Steel Institute, London, 1967.
5. E. Nes and S. Slevolden, "Mechanical Properties of New Strip Cast AlMnZr Alloys", *Aluminium* 55 (5) (1979) pp. 398-402.
6. R. Iricibar and I. Jin, "Forward Slip During Roll Casting of Aluminium Strip", in Pacific Northwest Metals and Minerals Conference, Spokane, Washington, 1982.



7. C.J. Moser, "Continuous Casting - Hunter Technology", pp. 837-849 in Light Metals 1982, J.E. Andersen, ed.; AIME, New York, N.Y., 1981.
8. J.M. Chateau and P. Crouzet, "Technological Break-through in Continuous Strip Casting: The Jumbo 3C", in Light Metals 1978, J.J. Miller ed.; AIME, New York, N.Y., 1978.
9. A. Odok and G. Thym, "Moderne Kontinuerlich arbeitende Bandgiessverfahren für die Herstellung von Aluminium Breitband", Aluminium, 50 (6) (1974) pp. 411-414.
10. I. Miki, H. Kosuge and K. Nagahama, "Supersaturation and Decomposition of Al-Fe Alloys during Solidification", Journal of Japan Inst. Light Metals, 25 (7) (1975) pp. 1-9.
11. H. Westengen, "Formation of Intermetallic Compounds During DC Casting of a Commercial Purity AlFeSi Alloy", Zeitschrift für Metallkunde 73 (6) (1982), pp. 360-368.
12. M. Ryvola, L.R. Morris and G. Marchand, "Nucleation of Intermetallic Phases on the Cast Surface of Al-Mn Alloys", pp. 23-29 in Microstructural Science, Vol. 6, J.E. Bennett, ed.; Elsevier North-Holland, 1978.
13. D. Altenpohl, Aluminium und Aluminiumlegierungen, p. 526; Springer Verlag, Berlin, 1965.
14. S. Bercovici, French Patent no. 8101185, 1981.