

INVESTIGATIONS ABOUT STARTING CRACKS  
IN DC-CASTING OF 6063-TYPE BILLETS  
Part II: MODELLING RESULTS

E K JENSEN

W SCHNEIDER

ELKEM ALUMINIUM LISTA  
N-4551 Farsund, Norway

VEREIGNIGTE ALUMINIUMWERKE  
D-5300 Bonn 1, W.Germany

Abstract

Influence on starting crack tendency of varying a number of casting parameters has been studied by experiments, Part I (1), and by model calculations, Part II. Both studies point to starting block shape as a most important single factor in controlling starting cracks. By using the thermal model ALSIM-2 in analysing initial experimental results, the variable heat transfer towards the starting block was determined. This made possible a satisfactory model analysis of the starting phase and likewise the formulation of a useful cracking concept. Thus by using calculated and measured liquid pool depth curve in the starting phase of casting as a basis, an effective starting block shape was found. This new shape practically eliminates the starting crack problems in extrusion billets of the AA6063 type alloys.

Introduction

The present paper results from international cooperative activities trying to minimize starting crack problems as explained in Part I (1). In parallel with the experiments and partly as a background for designing the experiments, it was decided to make simulations of the casting process by using the casting model ALSIM-2, (2),(3). This model is a true dynamic casting model, covering both the starting and middle phase of DC-casting. Experimental data should then be used to determine relevant heat transfer between the starting block and the billet. With this knowledge, further analysing, predictions and design of experiments would be possible.

Experimental details

It was chosen to study the performance of an 8" diameter extrusion billet during the starting phase of casting, using a level pouring mould of 30 mm non-insulated mould length, casting alloy 6063, 80 l/min water, 700 °C casting temperature, normal grain refiner additions.

Practical experiments started with the flat starting block shape as shown in Fig 1. Thermocouples were mounted in the starting block centre (1, 15, 21, 35 mm from top surface) as well as

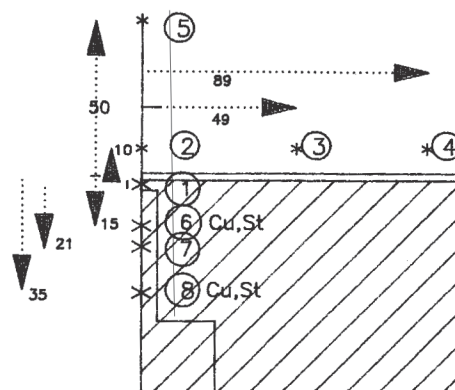

FIG 1  
THERMOCOUPLE POSITIONS FLAT STARTING BLOCK  
\*

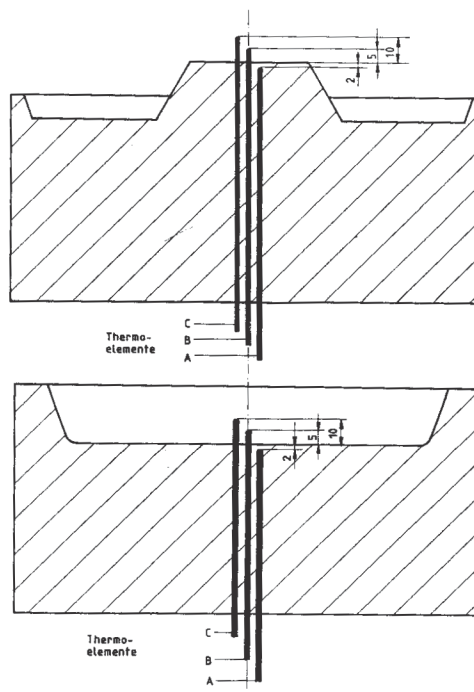

FIG 2 THERMOCOUPLE POSITIONS  
BOWL-SHAPED AND SPECIAL STARTING BLOCK

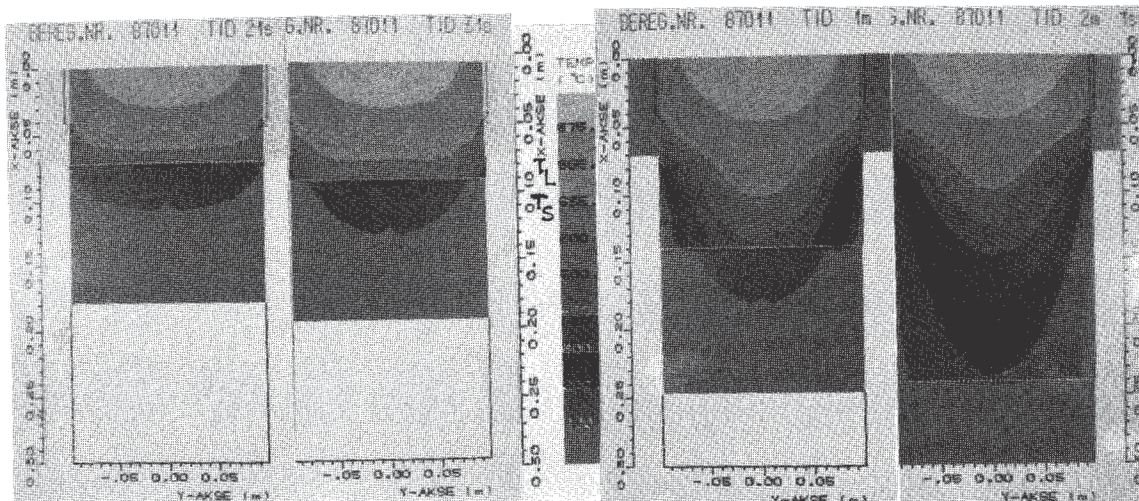

FIG 3 ALSIM-2 CASTING MODEL SIMULATIONS  
FIRST TWO MINUTES OF CASTING  
FLAT STARTING BLOCK

the starting end of the billet (10 and 50 mm into the billet). Temperatures were recorded by a standard 6-channel recorder.

Starting block materials of Al, Cu, Steel were examined.

Sump profiles were made visible by additions of AlCu45 in the launder at suitable intervals.

In another series of experiments, normal bowl-shaped starting blocks as well special shaped blocks were used with thermocouples positioned as shown in Fig 2.

(Further experimental details are covered in Part I (I) ).

Results and comments

Typical casting model simulation of the first two minutes of casting is shown in Fig 3, in this case using a flat Aluminium starting block. The calculations are based on heat transfer data resulting from initial analysing of experiments as explained next.

Temperatures and sump shape, flat starting block shape  
-----  
Calculated and measured temperature-time curves are shown in Fig 4 and Fig 5.

Fig 4 shows typical output results from modelling, examining a number of thermocouple positions.

Fig 5 a shows typical thermocouple 1-5 curves measured in the same casting.

By casting model analysis, suitable heat transfer coefficients were found, which could reproduce the observed temperature-time curves for the various thermocouple positions as well as reproduce the observed sump shape (re Fig 5 b-h and Fig 6).

The upper curve, Fig 6, follows from using a heat transfer coefficient of 4000 W/m<sup>2</sup>/oC between the bottom surface of the billet and starting block.

For the second curve, the coefficient value is reduced to 2000.

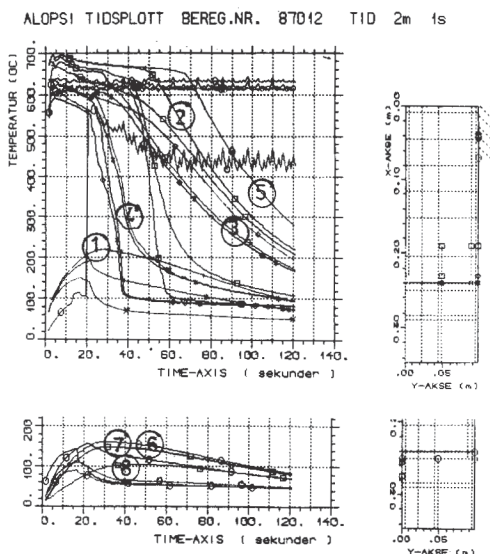

FIG 4 TEMPERATURE-TIME CURVES CALCULATED  
FLAT STARTING BLOCK

For the third curve, a coefficient of 2000 is again used at first in the beginning of casting. Later in the casting an air gap is introduced in the calculation for the outer part of the surface between the billet and the starting block (outer 54 mm of the radius) while heat transfer is assumed to remain unchanged in the centre.

Assumed heat transfer coefficient in the air gap : 300 w/m<sup>2</sup>/oC.

The air gap formation is further assumed to take place approximately when water first hits the billet surface exiting the mould, i.e. in this case about 20 s after start casting.

For the fourth curve, heat flow resistance corresponding to an air gap formation is specified all over the top surface of the starting block for comparison.

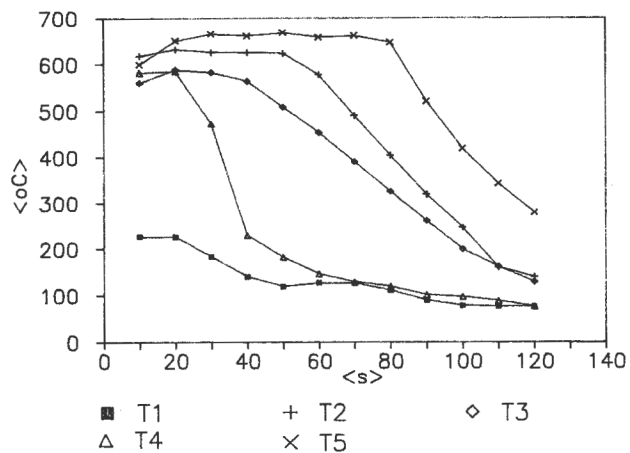

FIG 5 a THERMOCOUPLES 1-5 GUSS1-I  
FLAT STARTING BLOCK

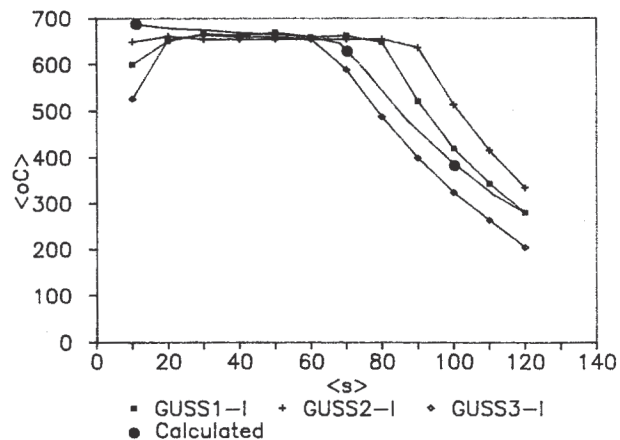

FIG 5 b THERMOCOUPLES 5 SERIES 1  
FLAT STARTING BLOCK

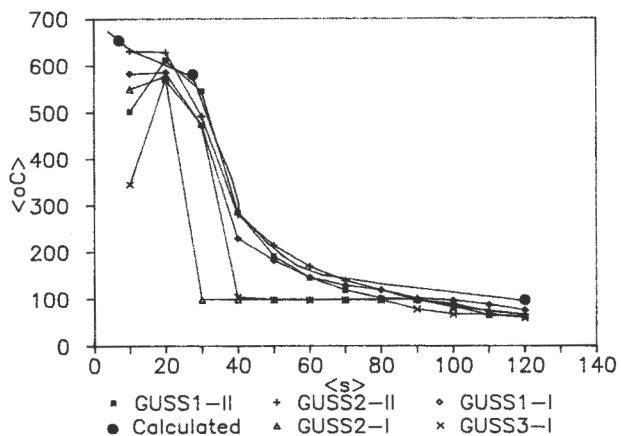

FIG 5 c THERMOCOUPLES 4 SERIES 1 & 2  
FLAT STARTING BLOCK

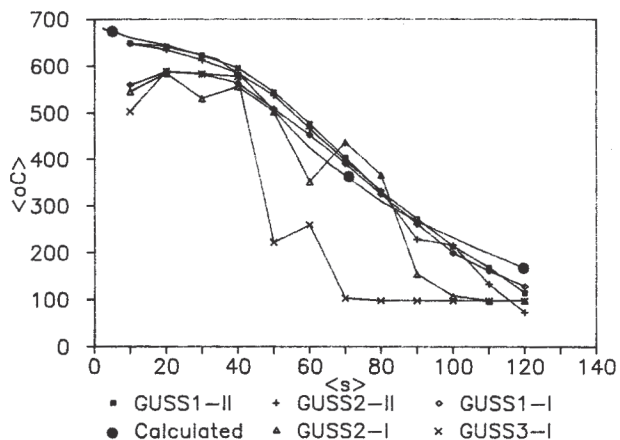

FIG 5 d THERMOCOUPLES 3 SERIES 1 & 2  
FLAT STARTING BLOCK

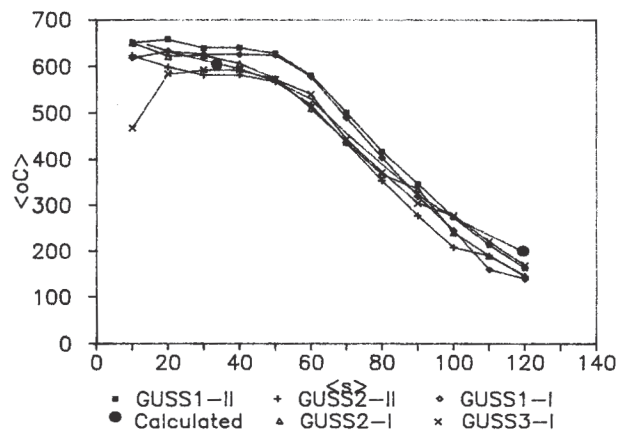

FIG 5 e THERMOCOUPLES 2 SERIES 1 & 2  
FLAT STARTING BLOCK

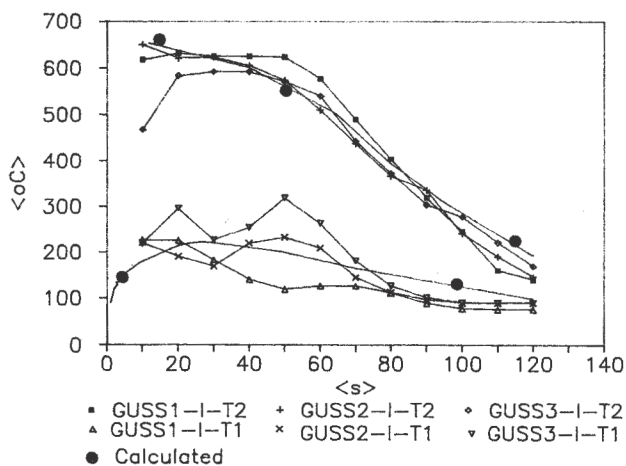

FIG 5 f THERMOCOUPLES 2 & 1 Series 1  
FLAT STARTING BLOCK

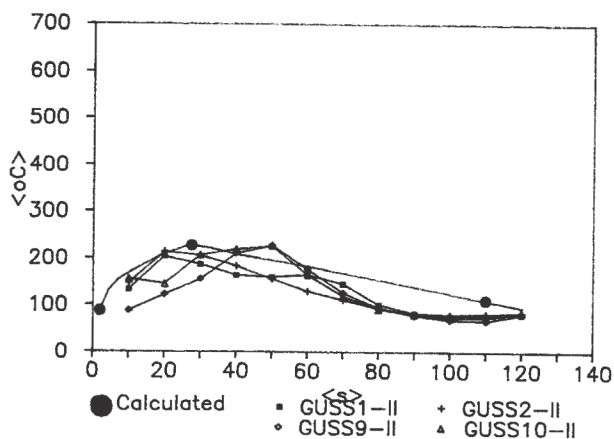

FIG 5 g THERMOCOUPLES 1 SERIES 2 FLAT STARTING BLOCK

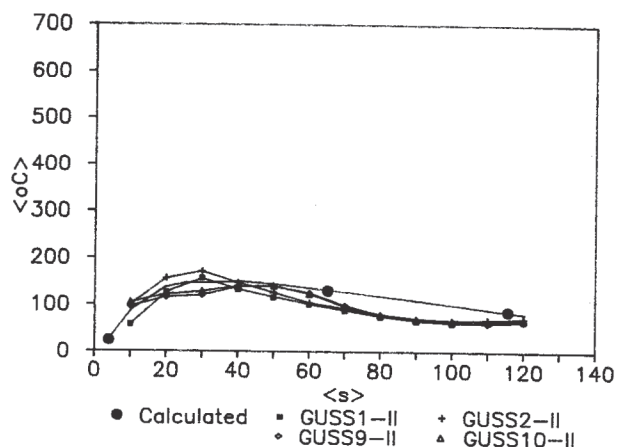

FIG 5 h THERMOCOUPLES 7 SERIES 2 FLAT STARTING BLOCK

The heat transfer coefficients for the third curve fit the experimental results best (temperature curves, Fig 5 b-h). These coefficients were then used (with some modifications) in studying effects following from using various starting block shapes as well as used in other studies.

As indicated above and clearly seen in Fig 5 : to describe the events in the starting phase properly, one has to consider that the heat transfer towards the starting block varies considerably with time. This reflects especially

(i) the loss of contact with the outer parts of the starting block as the billet starting-end curls upwards when the cooling water first hits the billet surface, re above.

(ii) Also there is a considerable variation in heat flow intensity from one casting to the next for the same thermocouple position, depending probably on the local mould filling process and local thermal contact conditions. These are clearly not identical from casting to casting.

It can be seen that when the heat transfer towards the starting block is relatively high and thus the corresponding temperatures of the starting block is high, the related billet temperatures becomes relatively low and vice versa (re e.g. Fig 5 f, thermocouple position T1 in the starting block centre, one mm below the surface and position T2, ten mm into the billet for Guss 1 versus T1 and T2 for Guss 3). Thus the variations are to a large degree real and not just due to measurement uncertainties.

Thermal criterion

When using a thermal model for (indirect) analysis and prediction of cracking situations, it is necessary to have a suitable thermal criterion to be associated with the cracking tendency.

It was found that depth of the liquid metal sump was a simple and most useful parameter to apply in analysing and predicting the risk for starting phase cracks. Characteristically, for normal starting blocks and casting conditions a maximum depth occurs in the starting phase of casting. This development takes place before the sump depth stabilizes at a not so deep level typical for the middle phase of casting, re Fig 6, 8, 9.

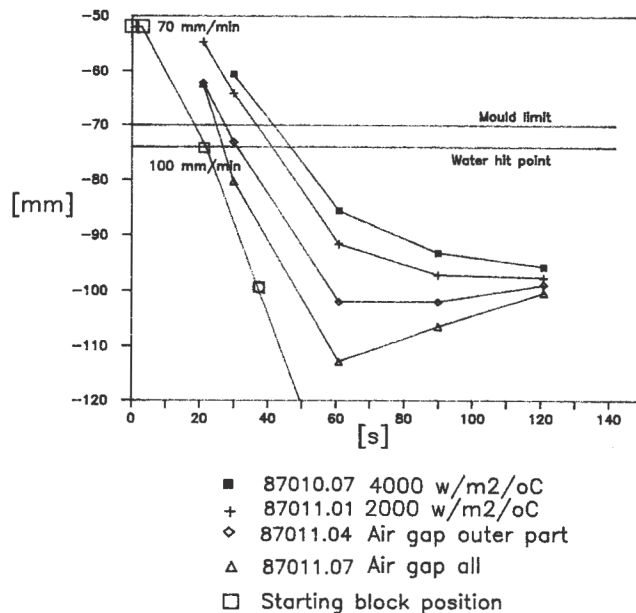

FIG 6 SUMP POSITIONS FLAT STARTING BLOCK VARIOUS HEAT TRANSFER COEFFICIENTS

It turns out that the tendency to form centre cracks in the starting phase can be associated with this maximum sump depth on the sump depth curve. At this point, the sump is often deeper than the sump depth at the critical casting rate when cracks develop in the middle phase of casting.

Actions leading to elimination of this maximum depth will effectively prevent or minimize the starting cracks. Vice versa : actions leading to deeper sumps will also worsen a centre crack problem.

The fact that such a maximum depth easily occurs must reflect the following: in the billet centre the solidification front initially solidifies and moves upwards with a rate that is less than the usual initial casting rate downwards. This is caused by the relatively low rate of heat transfer in the first (mould-filling) stage of casting, i.e. when the main flow of heat is into the starting block.

At this stage, the heat flow rate is limited by the contact resistance between the bottom surface of the billet and the top surface of the starting block. The resulting deepening process of the liquid sump will proceed in this non-stationary phase of casting until the starting block exits the mould and the more efficient heat transfer by direct water cooling takes effect. A heat balance is subsequently found at a higher (not so deep) sump level, typical for the middle/stationary phase of casting.

The critical time period in which the sump easily becomes too deep - and the billet is most cracking prone - can be influenced by several means :

Casting rate in the start

The obvious and often used action, namely to start with reduced casting rate for a suitable casting distance, can be helpful in reducing cracking problems as it gives more time for solidification and movement upwards versus downwards in the billet centre. Positive effects were confirmed in the practical experiments Part I (1). It can rarely be fully utilized, however, because of associated bad surface/freezing problems. Especially, the most cracking-prone alloys will not be helped effectively.

Mould filling time

By physically forcing the sump profile in the billet centre to start its downwards movement from a high enough level, better effects can be obtained. One way to obtain this is to use suitably long mould filling/ holding times before start of casting. Again there can be problems with reproducibility and temperature/freezing problems.

Starting block material

Changing the starting block material itself changes the temperatures and the sump depth maximum in correspondence with the change of thermal properties of the starting block. This goes in parallel with the cracking tendency.

Fig 7 and 8 illustrate the case. Measurements were made with thermocouples positioned 15 and 35 mm below starting block top surface, Fig 7 a and b for Cu and steel blocks respectively (thermocouples 6 and 8 in Fig 1). In Fig 7c are shown calculations for points positioned 1, 15, 21 and 35 mm below the surface (thermocouples 1, 6-8 in Fig 1) for Al, Cu and steel. By using the same heat transfer data as explained earlier, the top of the steel-block is calculated to become considerably warmer and the Cu-block colder than the Al-block. The steel-block is also predicted to lead to a deeper sump (in principle more cracking-prone casting) and the Cu-block to a more shallow sump (less cracking prone casting) than the Al-block, Fig 8. Though the effect on sump depth of varying the starting block material/conductivity is not very marked for the flat starting block, with other shapes

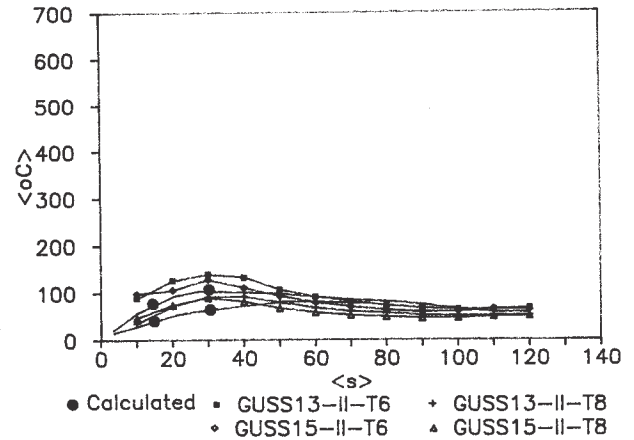

FIG 7 a THERMOCOUPLES 6, 8 SERIES 2 Cu FLAT STARTING BLOCK

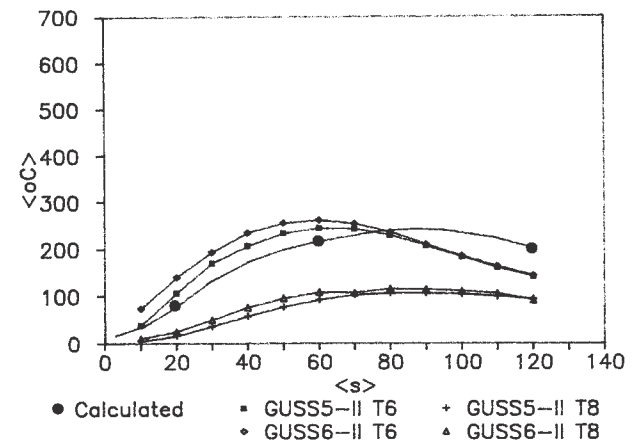

FIG 7 b THERMOCOUPLES 6, 8 SERIES 2 STEEL FLAT STARTING BLOCK

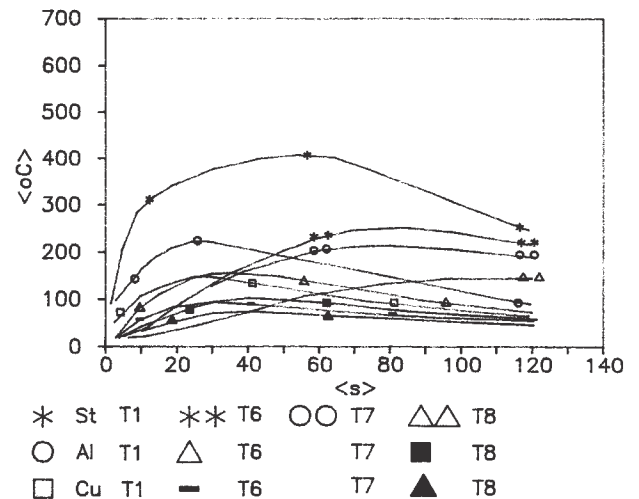
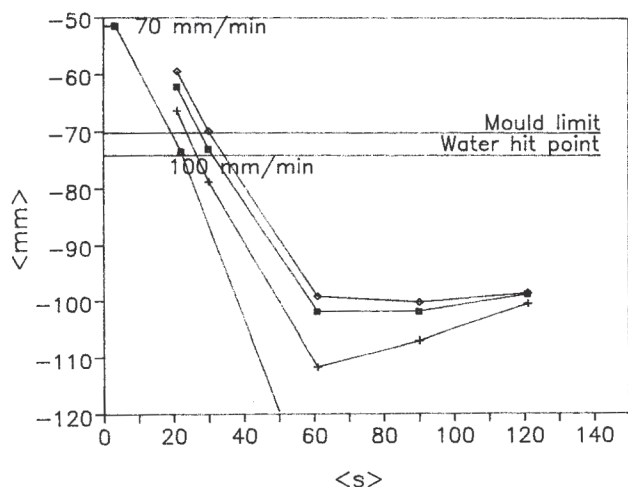

FIG 7 c THERMOCOUPLES 1, 6, 7, 8 St, Al, Cu FLAT STARTING BLOCK ALL CALCULATED

(e.g. the traditional bowl shape) and in borderline cases at least, the effect could be more decisive. This became more clear after calculations and experiments with alternative starting block shapes.



87011.04 Starting block Al + 87013.01 Steel  
 87015.01 Starting block position    87014.01 Cu

FIG 8 SUMP POSITIONS FLAT STARTING BLOCK VARIOUS STARTING BLOCK MATERIALS

The flat block can best be seen as a step away from the relatively inferior bowl shape towards further improved shapes discussed next.

Bowl-shaped starting block

Fig 2a shows the more traditional starting block shape. Because of low initial casting position in the centre for the bowl-shaped starting block relative to the flat starting block, an even more pronounced liquid sump depth maximum develops in the beginning of casting, re Fig 9 as well as Part 1 (1). Measured and calculated temperature-time curves are shown in Fig 10.

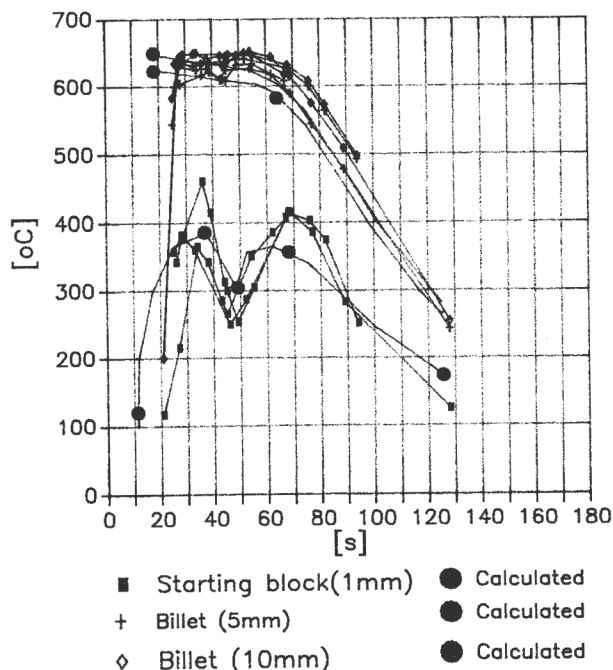

FIG 11 TEMPERATURES IN BILLET AND STARTING BLOCK SPECIAL STARTING BLOCK (CONE)

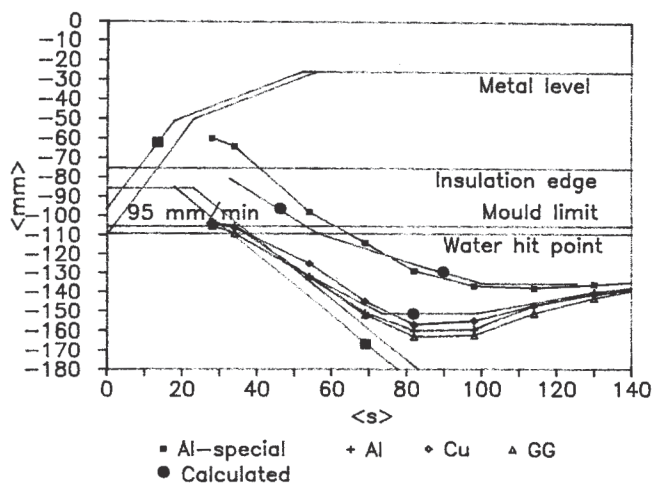

FIG 9 SUMP DEPTHS SPECIAL/NORMAL BOTTOM BLOCK

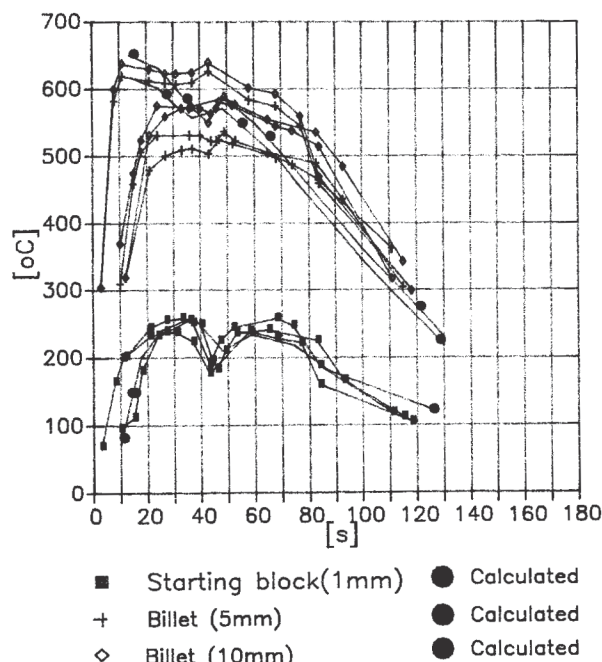

FIG 10 TEMPERATURES IN BILLET AND STARTING BLOCK BOWL-SHAPED STARTING BLOCK

Special starting block shape

Finally, Fig 2 b shows an example of a more suitable starting block shape giving far less starting crack problems than all other shapes or measures tried in order to solve the cracking problem. The effect is to physically displace the sump upwards to a higher starting position at the beginning of casting. This eliminates the sump depth maximum as can also be seen in Fig 9. Measured and calculated sump curves are shown for the special block shape as well as normal block shape of Al, Cu, Cast iron (GG). As demonstrated in part I (1), starting cracks are now for practical purposes eliminated. Measured and calculated temperature-time curves are shown in Fig 11.

Both for bowl-shaped and the special shaped starting blocks, temperature-time curves show a pronounced dip in the temperature curve for the starting block. This coincides with the time when water first hits the billet surface and lasts for about 15 s.

For the billet, there is a corresponding increase in temperature.

This has been modelled in the calculations by assuming that the subsequent loss of good contact between the billet and the starting block extend inwards to about 20 mm from the billet centre. After about 15 s, good contact is re-established between 20 and 40 mm from the billet centre.

In these experiments, it seems that the good contact in the variable contact area in the centre now could correspond with heat transfer coefficients of maybe as high as 3000 w/m<sup>2</sup> oC.

#### Conclusions

-----

\* By analysing initial experimental results, heat transfer data was found that could be used to simulate the non-stationary starting phase of casting in detail.

\* The heat transfer coefficient can vary considerably both with time and radial position due to butt curling and other variations locally, time-wise and between casts.

\* Once a suitable thermal cracking criterion was formulated however, cracking risk could be predicted and effective solutions pointed out.

\* A simple and most useful cracking criterion proved to be the avoidance of excessive liquid sump depths in the starting phase. As seen by calculations and experiments, the risk for starting cracks is in principle reduced by :

\* changing the starting block material going from Steel/Cast-iron to Al to Cu

\* reducing initial casting rate

\* changing the bottom block shape from a bowl (concave) shape to a flat shape to a conical (convex) shape.

\* It is clearly demonstrated that starting block shape is a most effective, single factor that can be utilized to eliminate/minimize centre cracks and butt scrap.

This was verified by the presence/absence and length of starting cracks and by surface quality in the start as shown in part I (1).

In other words: in this respect the traditional (more or less deep) bowl-shaped starting block was not well chosen.

#### References

-----

(1) W.Schneider, E.K.Jensen: Investigations about starting cracks in DC-casting of 6063-type billets. Part I: Experimental results, 119 AIME Annual Meeting 1990.

(2) Alsim casting models, resulting from a Norwegian cooperative project by Hydro Aluminium, Elkem Aluminium and Institute for Energy Technology (IFE).

(3) E.Madsen, H.Fossheim: Application of a mathematical model in level pour DC-casting of sheet ingots, Light Metals 1979 (109 AIME Annual Meeting 1979).