

## ELECTRICAL CONDUCTIVITY OF MOLTEN CRYOLITE-BASED MIXTURES OBTAINED WITH A TUBE-TYPE CELL MADE OF PYROLYTIC BORON NITRIDE

J. Hivěš\*, J. Thonstad, Å. Sterten and P. Fellner\*

Department of Electrochemistry, Norwegian Institute of Technology,  
University of Trondheim, N-7034 Trondheim, Norway\* Permanent address: Department of Inorganic Technology, Slovak Technical University, Radlinského 9,  
812 37 Bratislava, SlovakiaAbstract

A pyrolytic boron nitride tube-type cell was used to measure the electrical conductivity for molten cryolite, for binary mixtures of cryolite with  $Al_2O_3$ ,  $AlF_3$ ,  $CaF_2$ ,  $KF$ ,  $Li_3AlF_6$ , and  $MgF_2$ , and for ternary mixtures  $Na_3AlF_6 - Al_2O_3 - CaF_2$  ( $MgF_2$ ) and  $Na_3AlF_6 - AlF_3 - KF$  ( $Li_3AlF_6$ ). The cell constant was about  $40\text{ cm}^{-1}$ . The temperature and concentration dependence of the conductivity in the investigated concentration range was described by the equation

$$\ln \kappa = 1.977 - 0.0200[Al_2O_3] - 0.0131[AlF_3] - 0.0060[CaF_2] \\ - 0.0106[MgF_2] - 0.0019[KF] + 0.0121[LiF] - 1204.3/T$$

where  $T$  represents the temperature in K, and the brackets denote the concentration of the additives in wt%.

Introduction

Investigations of the electrical conductivity of molten cryolite-based systems have been an area of active research in recent years. Melts based on sodium cryolite ( $Na_3AlF_6$ ) serve as solvent for alumina in the electrolyte used in the production of aluminium [1]. Cryolite is a high melting compound ( $1012\text{ }^\circ\text{C}$ ), and it is advantageous to use a lower melting electrolyte [2 - 4]. This can be done by the use of more acid ( $AlF_3$ -rich) bath and/or by the introduction of certain additives, such as  $LiF$ ,  $CaF_2$ , and  $MgF_2$ . With decreasing temperature one might expect an increase in the current efficiency, lower energy consumption and, possibly, prolonged cell life and easier adaptation of inert electrode materials.

However, the electrical conductivity of the electrolyte decreases both with increasing contents of most additives ( $AlF_3$ ,  $CaF_2$ ,  $MgF_2$ ,  $KF$ ) and with decreasing temperature [1]. This unfavourable effect can partly be compensated by the addition of  $LiF$ . In industrial production of aluminium, it is desirable to have an electrolyte with a high electrical conductance. Thus it is not surprising that the literature dealing with this topic is rather extensive [1, 5 - 8].

The major difficulty in determining conductivities of fused fluorides is to select a suitable material for the conductance cell. It should not be attacked by the melt, it should be an electrical insulator at temperatures around  $1000\text{ }^\circ\text{C}$ , and it should possess dimensional stability at these temperatures. It seems that pyrolytic boron nitride is the most suitable material for this purpose [5, 6, 9]. Most of the available conductivity data for molten cryolite-based mixtures were obtained with all-metal cells (platinum and its alloys). The measured electrolyte resistance of such cells is usually less than

1 ohm, and electrode polarization becomes a major problem [10] to determine the true resistivity of the electrolyte. Recently a novel experimental technique with moving electrodes (Continuously Varying Cell Constant) for tube type cells made of pyrolytic boron nitride was developed by Wang et al. [5] and by Kim and Sadoway [9], to increase the reproducibility of the measured data. However, this technique was not adopted in the present work.

In 1973 Choudhary [11] published an equation based on a regression analysis of the conductivity data for cryolite melts available at that time,

$$\ln \kappa = 2.0156 - 0.0207(\% Al_2O_3) - 0.0049(\% CaF_2) \\ - 0.0166(\% MgF_2) + 0.0178(\% LiF) \\ + 0.0063(\% NaCl) + 0.0077(\% Li_3AlF_6) \\ + 0.2175CR - 2068.4/T \quad (1)$$

where  $CR$  denotes the  $NaF/AlF_3$  molar ratio, the concentrations are in wt% and  $T$  is the absolute temperature. This equation has been widely used since, and in the following some of the experimental data will be compared with conductivities calculated from this equation.

The objective of the present work is to provide conductivity data for binary, ternary and multicomponent cryolite-based mixtures obtained with a tube-type cell made of pyrolytic boron nitride with stationary electrodes. The same technique was previously used to measure conductivities of electrolytes used for electrolytic refining of aluminium [12].

Experimental

A schematic drawing of the cell is shown in Fig. 1. The cell consisted of a pyrolytic boron nitride tube (Boralloy, Union Carbide) of inner diameter *ca* 4 mm and length 100 mm. One electrode consisted of a tungsten rod (2 mm  $\varnothing$ ) placed in a fixed position inside the BN-tube, while the graphite crucible served as the other electrode. The crucible containing a 10 - 15 g sample of the salt mixture was placed in a vertical laboratory furnace with argon atmosphere and heated up to the required temperature. The boron nitride tube with the tungsten electrode was immersed in the melt and repositioned several times to make sure that the composition of the electrolyte was homogeneous and that any gas bubbles were removed. The temperature was measured with a Pt-Pt10%Rh thermocouple, and it was stable within 0.5 K. Within a run the measurements were carried out at different temperatures (typically at 4 or 5 temperatures) for every composition.

A Solartron 1250 Frequency Response Analyser which was

used in the beginning [6, 8] was replaced with an Impedance/Gain-Phase Analyzer (Solartron 1260) to measure the cell impedance. The *ac* amplitude was 10 mV, and 32 readings were taken within the frequency range of 6 to 60 kHz. The real part of the cell impedance was plotted as a function of the inverse square root of the angular frequency, and the resistance of the electrolyte was obtained by extrapolation to infinite frequency [10, 13, 14], subtracting the resistivity of the leads and the electrodes.

Chemicals

Hand-picked crystals of Greenland cryolite (Na<sub>3</sub>AlF<sub>6</sub>) and AlF<sub>3</sub> sublimed under low pressure (ca 100 Pa) at 1100 °C were used. LiF, KF, CaF<sub>2</sub>, MgF<sub>2</sub> were of analytical grade (Merck) or higher. To determine the cell constant NaCl (specpure, Johnson Matthey) was used. All chemicals were treated by vacuum drying at 400 °C for several hours prior to melting.

Cell constant

The cell constant was determined with sodium chloride based on data for the conductivity of molten sodium chloride recommended by Janz [15]. The cell constant did not vary with the temperature. During measurements the cell constant was measured at intervals, and for one and the same tube it was found to remain constant, indicating that a gradual penetration of the melt into the tube did not occur.

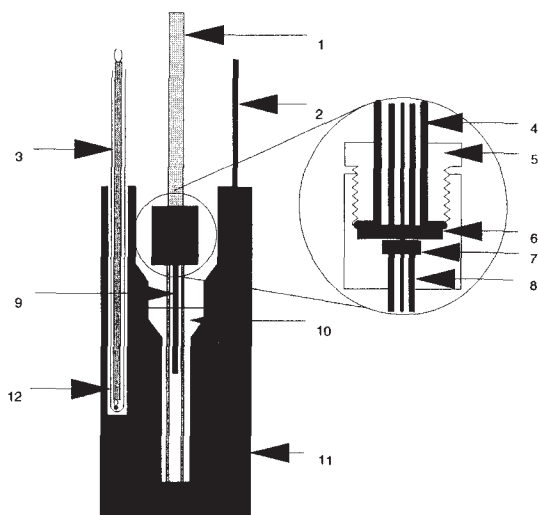

Figure 1: Cross-section of the conductivity cell; 1,4 - stainless steel tube, 2 - stainless steel contact rod, 3 - thermocouple, 5 - BN body of the electrode attachment, 6 - BN insulating ring, 7 - stainless steel ring, 8 - BN pyrolytic tube, 9 - tungsten electrode, 10 - melt, 11 - graphite crucible, 12 - alumina tube.

Results and Discussion

Binary systems Na<sub>3</sub>AlF<sub>6</sub> - x (x = Al<sub>2</sub>O<sub>3</sub>, AlF<sub>3</sub>, CaF<sub>2</sub>, KF, Li<sub>3</sub>AlF<sub>6</sub>, MgF<sub>2</sub>)

It was found that within the limits of error the experimental data for the conductivity of binary cryolite-based melts summarized in this work could be described by an equation of the type

$$\kappa / S cm^{-1} = 7.22 \exp(-1204.3 / T) + a_i x_i \tag{2}$$

where T is the temperature in K, a<sub>i</sub> is the coefficient and x<sub>i</sub> is the mole fraction of the additive, which can be converted to weight fraction by the equation

$$x_i = \frac{\frac{w_i}{M_i}}{\sum \frac{w_i}{M_i}} \tag{3}$$

where w<sub>i</sub> is the mass fraction of the additive and M<sub>i</sub> is the molar weight of the components of the mixture. Values of the coefficients a<sub>i</sub>, obtained by a least square method, with the range of validity of equation (2) and the standard deviation are summarized in Table I and shown graphically in Figs. 2-7.

Table I Parameters of equation (2) describing the electrical conductivity of binary cryolite-based mixtures at temperatures ranging from the melting point to 1090 °C

Component	a <sub>i</sub>	stand.deviation κ/ S cm <sup>-1</sup>	range w <sub>i</sub> wt %	range x <sub>i</sub> mole %
Al <sub>2</sub> O <sub>3</sub>	- 2.53	0.015	0 - 11	0 - 20
AlF <sub>3</sub>	- 1.66	0.022	0 - 28	0 - 50
CaF <sub>2</sub>	- 0.76	0.023	0 - 14	0 - 30
MgF <sub>2</sub>	- 1.07	0.031	0 - 14	0 - 35
KF	- 0.206	0.011	0 - 15	0 - 39
Li <sub>3</sub> AlF <sub>6</sub>	+ 0.97	0.022	0 - 34	0 - 40

The first term in equation (2) describes the temperature dependence of the conductivity of pure molten Na<sub>3</sub>AlF<sub>6</sub>. The model used to describe the temperature and concentration dependencies of the electrical conductivity of cryolite-based melts is based on the assumption that the activation energy of the process does not depend on composition, provided that the concentration of Na<sub>3</sub>AlF<sub>6</sub> exceeds 50 mole %. The parameters in the first term were determined only from the data for the binary mixtures Na<sub>3</sub>AlF<sub>6</sub> - Al<sub>2</sub>O<sub>3</sub> and Na<sub>3</sub>AlF<sub>6</sub> - AlF<sub>3</sub> for the following three reasons:

- (i) The experimental conductivity data obtained for the molten system Na<sub>3</sub>AlF<sub>6</sub> - Al<sub>2</sub>O<sub>3</sub> showed considerably less scatter and better reproducibility than measurements carried out in the other systems (see Table I; the measurements with KF, provided later, confirmed this choice). This behaviour may be related either to the electrochemical reactions occurring at the electrodes or to differences in the wetting of the boron nitride tube by the melt.
- (ii) The use of melts with high contents of aluminium fluoride (up to 28 wt%) made it possible to investigate the electrical conductivity at temperatures down to 850 °C.
- (iii) It is also important to note that within the limits of error the conductivity in the investigated concentration range varies linearly with the mole fraction of alumina and/or aluminium fluoride. This linear dependence on composition expressed in mole fractions may be explained on the basis of models of electrical conductivity of molten mixtures [16].

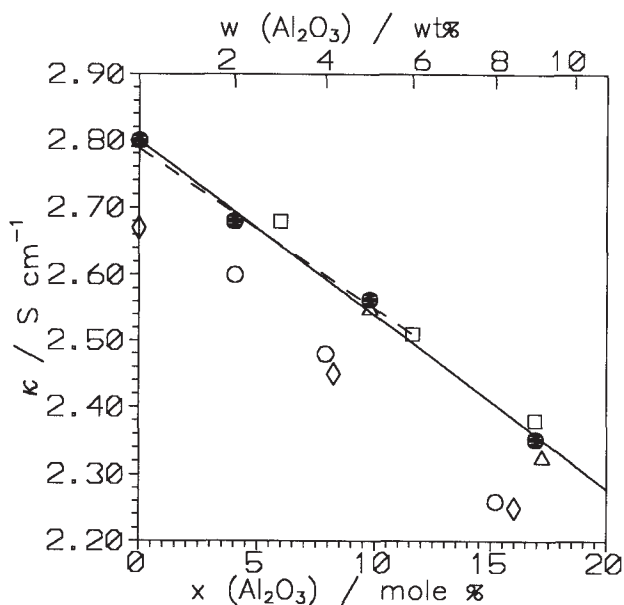

Figure 2: The electrical conductivity of  $\text{Na}_3\text{AlF}_6 - \text{Al}_2\text{O}_3$  mixtures at 1000 °C. Filled circles and full line, this work; ( $\Delta$ ) Edwards et al. [17]; ( $\square$ ) Matiasovsky et al. [18]; ( $\circ$ ) Yim and Feinleib [19]; ( $\diamond$ ) Abramov et al. [20], dashed line - Wang et al. [7].

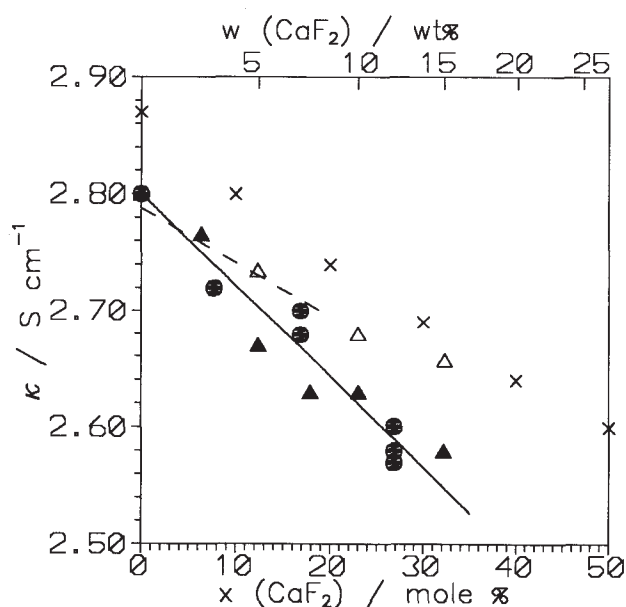

Figure 4: The electrical conductivity of  $\text{Na}_3\text{AlF}_6 - \text{CaF}_2$  mixtures at 1000 °C. Filled circles and full line, this work; ( $\Delta$ ) Edwards et al. [17]; ( $\times$ ) Janz and Tomkins [22]; ( $\blacktriangle$ ) Peterson [23], dashed line - Wang et al. [7].

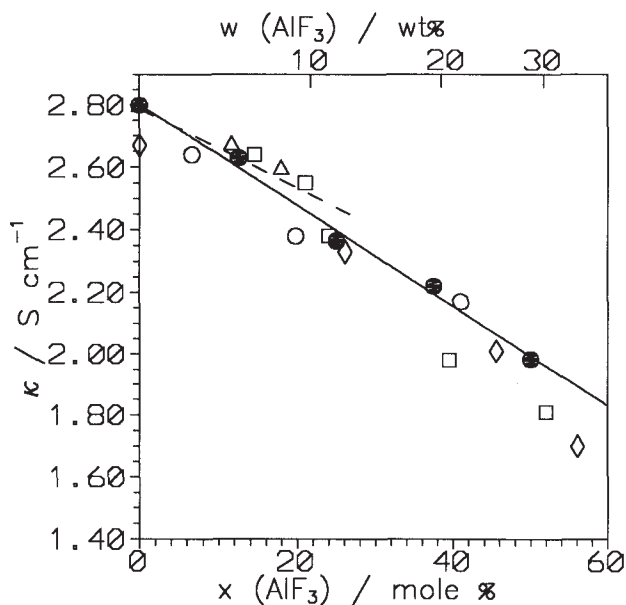

Figure 3: The electrical conductivity of  $\text{Na}_3\text{AlF}_6 - \text{AlF}_3$  mixtures at 1000 °C. Filled circles and full line, this work; ( $\Delta$ ) Edwards et al. [17]; ( $\square$ ) Matiasovsky and Danek [21]; ( $\circ$ ) Yim and Feinleib [19]; ( $\diamond$ ) Abramov et al. [20], dashed line - Wang et al. [7].

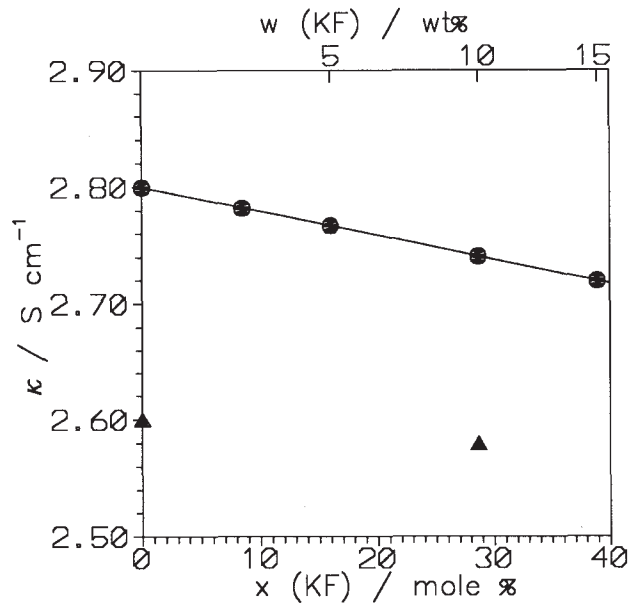

Figure 5: The electrical conductivity of  $\text{Na}_3\text{AlF}_6 - \text{KF}$  mixtures at 1000 °C. Filled circles and full line, this work; ( $\blacktriangle$ ) Kuvakin et al. [24].

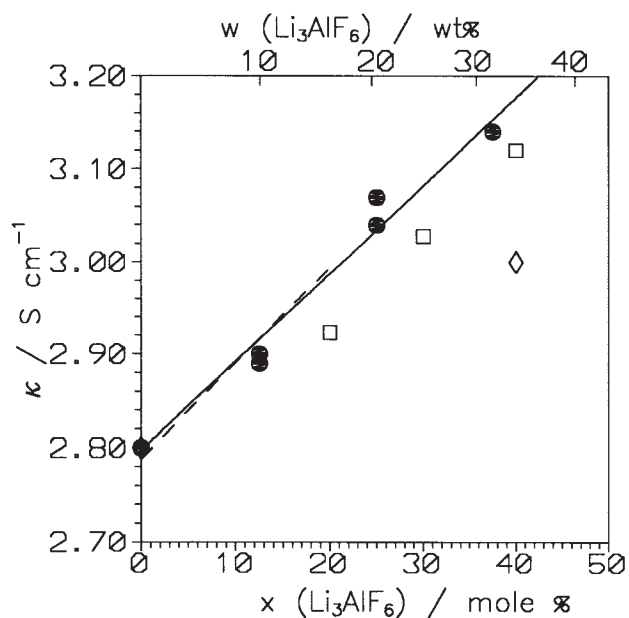

Figure 6: The electrical conductivity of Na<sub>3</sub>AlF<sub>6</sub> - Li<sub>3</sub>AlF<sub>6</sub> mixtures at 1000 °C. Filled circles and full line, this work; (□) Danek et al. [25]; (◇) Abramov et al. [26], dashed line - Wang et al. [7].

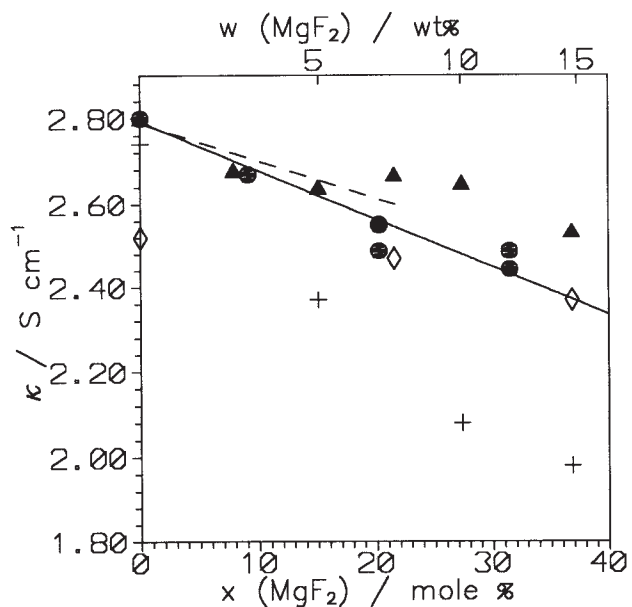

Figure 7: The electrical conductivity of Na<sub>3</sub>AlF<sub>6</sub> - MgF<sub>2</sub> mixtures at 1000 °C. Filled circles and full line, this work; (◇) Abramov et al. [26]; (▲) Peterson [23]; (+) Belyaev [27], dashed line - Wang et al. [7].

The conductivities reported in this work are compared with literature data in Figs. 2 - 7. The comparison is made at 1000 °C. In the cases where the temperature dependence of the conductivity was not given in the cited papers, the data were converted to 1000 °C using the temperature dependence obtained in the present work.

The ternary systems Na<sub>3</sub>AlF<sub>6</sub> - Al<sub>2</sub>O<sub>3</sub> - CaF<sub>2</sub> and Na<sub>3</sub>AlF<sub>6</sub> - Al<sub>2</sub>O<sub>3</sub> - MgF<sub>2</sub>

The electrical conductivity of the Na<sub>3</sub>AlF<sub>6</sub> - Al<sub>2</sub>O<sub>3</sub> - CaF<sub>2</sub> system in the investigated concentration range can be described by the equation

$$\kappa / S cm^{-1} = 7.22 \exp(-1204.3/T) - 2.53[Al_2O_3] - 0.76[CaF_2] - 1.80[Al_2O_3][CaF_2] \quad (4)$$

and the conductivity of the Na<sub>3</sub>AlF<sub>6</sub> - Al<sub>2</sub>O<sub>3</sub> - MgF<sub>2</sub> system can be described by the equation

$$\kappa / S cm^{-1} = 7.22 \exp(-1204.3/T) - 2.53[Al_2O_3] - 1.07[MgF_2] - 2.59[Al_2O_3][MgF_2] \quad (5)$$

where T represents the temperature in K and the brackets represent the mole fractions of the additions, which can be converted to weight fractions using equation (3).

Fig. 8 shows experimental data as a function of temperature for different compositions in the system Na<sub>3</sub>AlF<sub>6</sub> - Al<sub>2</sub>O<sub>3</sub> - CaF<sub>2</sub>. The solid lines represent equation (4) for the same composition. For the composition with the highest Al<sub>2</sub>O<sub>3</sub> concentration (11.25 wt%) the measured values are lower than predicted by equation (3). The reason may be that the content of alumina in this mixture at decreasing temperatures exceeded the saturation limit. The standard deviation was found to be 0.023 S cm<sup>-1</sup>.

Only a few values for the electrical conductivity of this ternary system are available in the literature [17, 19, 32]. Data published by Vajna [32] differ considerably from all others (addition of CaF<sub>2</sub> increases the conductivity). Edwards et al. [17] and Yim and Feinleib [19] published conductivity data for this system which are summarized in Table II together with the present data.

Table II Electrical conductivity data for the ternary system Na<sub>3</sub>AlF<sub>6</sub> - Al<sub>2</sub>O<sub>3</sub> - CaF<sub>2</sub> adjusted to the temperature of 1000 °C

Composition / wt%			Electrical conductivity / S cm <sup>-1</sup>		
Na <sub>3</sub> AlF <sub>6</sub>	CaF <sub>2</sub>	Al <sub>2</sub> O <sub>3</sub>	Edwards et al.[17]	Yim and Feinleib [19]*	This work
85	10	5	2.44	-	2.39
90	8	2	-	2.57	2.56
88	8	4	-	2.41	2.47
84	8	4	-	2.21	2.29

\* Data read from graphs

The data of Edwards et al. are about 2% higher than the present data. The reason for this could be that for calibration these authors

used data for molten sodium chloride which were higher than those recommended by Janz [15]. The difference between the values obtained by Yim and Feinleib [19] and the corresponding values from the present work increases with increasing content of  $Al_2O_3$ . This observation is in accordance with the fact that the absolute values of the conductivities determined by Yim and Feinleib [19] for  $Na_3AlF_6 - Al_2O_3$  binary mixtures are low compared with our previous work [6] while the data for the  $Na_3AlF_6 - CaF_2$  system are consistent with our data [6].

Recently Wang et al. [7] reported an extensive set of conductivity data for multicomponent molten cryolitic systems and an equation obtained from multiple regression analysis of these data. The electrical conductivity data derived from the equation of Wang et al. [7] for the  $Na_3AlF_6 - Al_2O_3$  system gives excellent agreement with equation (4) of the present work, as illustrated in Fig. 2. The data for the binary  $Na_3AlF_6 - CaF_2$  and the ternary  $Na_3AlF_6 - Al_2O_3 - CaF_2$  systems are also in a fair agreement although the coefficients for  $CaF_2$  differ (Fig. 4).

Fig. 9 shows experimental data as a function of temperature for different compositions in the system  $Na_3AlF_6 - Al_2O_3 - MgF_2$ . The full lines represent equation (5) for the same composition. The agreement with the measured data was quite good, with a standard deviation of  $0.015 S cm^{-1}$ .

The conductivity of this ternary system was measured by Vatslavik and Belyaev [28]. These authors found a marked decrease in conductivity already at low  $MgF_2$  concentrations [1]. The negative effect of  $MgF_2$  or  $Al_2O_3$  on the conductivity in the binary systems  $Na_3AlF_6 - MgF_2$  or  $Na_3AlF_6 - Al_2O_3$  was much stronger than found in the present work. Also in this case good agreement was achieved between the data derived from the equation of Wang et al. [7] and equation (5) for the binary system  $Na_3AlF_6 - MgF_2$  and for the ternary system  $Na_3AlF_6 - Al_2O_3 - MgF_2$ . The negative influence on conductivity was stronger for  $MgF_2$  than for  $CaF_2$ .

The ternary systems  $Na_3AlF_6 - AlF_3 - Li_3AlF_6$  and  $Na_3AlF_6 - AlF_3 - KF$

The molar ratio of  $Li_3AlF_6$  and  $AlF_3$  in the ternary system  $Na_3AlF_6 - Li_3AlF_6 - AlF_3$  was chosen to be 1:2. This composition range was selected on the basis of investigations of losses of aluminium and current efficiency [4] and solubility of alumina [29] in electrolytes with temperatures of primary crystallization as low as  $800^\circ C$ .

It was found that within the investigated concentration range the experimental conductivity data of the  $Na_3AlF_6 - AlF_3 - Li_3AlF_6$  system can be described by the equation,

$$\kappa / S cm^{-1} = 7.22 \exp(-1204.3 / T) - 1.66 [AlF_3] + 0.97 [Li_3AlF_6] - 0.942 [AlF_3] [Li_3AlF_6] \tag{6}$$

and for the system  $Na_3AlF_6 - AlF_3 - KF$ ,

$$\kappa / S cm^{-1} = 7.22 \exp(-1204.3 / T) - 1.66 [AlF_3] - 0.206 [KF] \tag{7}$$

where the brackets represent the mole fractions of the additives  $AlF_3$  and  $Li_3AlF_6$  or  $KF$ , respectively.

The standard deviation was found to be  $0.015 S cm^{-1}$  for the former ternary system and  $0.011 S cm^{-1}$  for the latter. The term representing component interaction in equation (6) is rather small, and it exceeds the experimental uncertainty only when the product

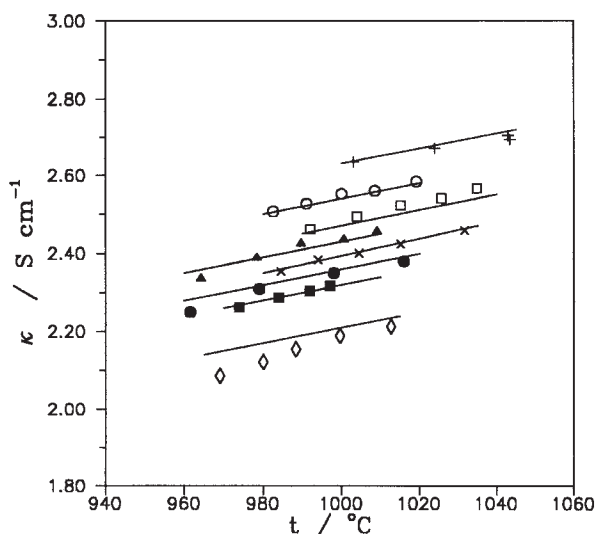

Figure 8: The electrical conductivity of  $Na_3AlF_6 - CaF_2 - Al_2O_3$  mixtures as a function of temperature; compositions in wt%  $CaF_2$  and wt%  $Al_2O_3$  respectively, as follows: (+) 2.50, 2.50 ; (○) 7.50, 2.50 ; (□) 5.00, 5.00 ; (▲) 11.25, 3.75 ; (×) 2.50, 7.50 ; (●) 12.00, 5.00 ; (■) 7.50, 7.50 ; (◇) 3.75, 11.25 ; full line equation (3).

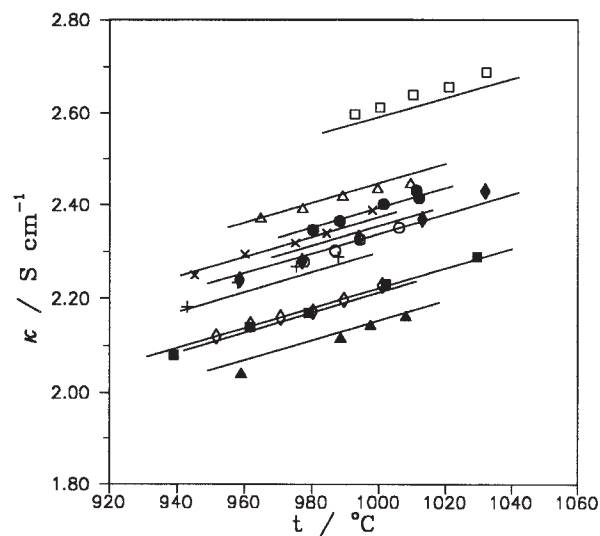

Figure 9: The electrical conductivity of  $Na_3AlF_6 - MgF_2 - Al_2O_3$  mixtures as a function of temperature; compositions in wt%  $MgF_2$  and wt%  $Al_2O_3$  respectively, as follows: (□) 2.50, 2.50 ; (Δ) 7.50, 2.50 ; (●) 5.00, 5.00 ; (×) 14.00, 1.00 ; (◆) 7.00, 5.00 ; (○) 2.50, 7.50 ; (+) 11.25, 3.75 ; (◇) 7.50, 7.50 ; (■) 12.00, 5.00 ; (▲) 3.75, 11.25 ; full line equation (4).

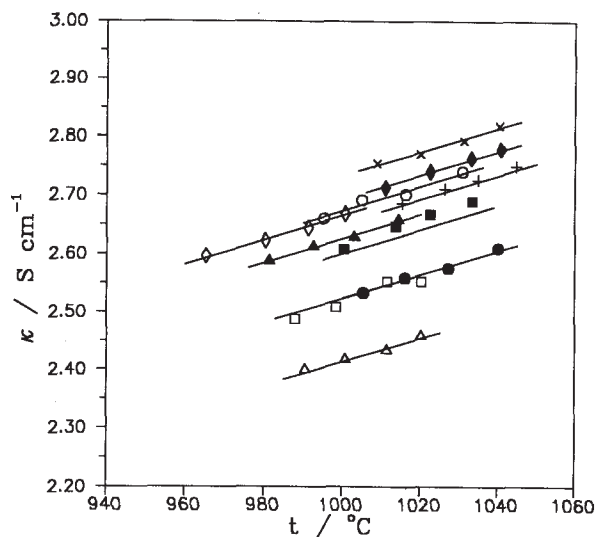

Figure 10: The electrical conductivity of  $\text{Na}_3\text{AlF}_6$  -  $\text{KF}$  -  $\text{AlF}_3$  mixtures as a function of temperature, compositions in wt%  $\text{KF}$  and wt%  $\text{AlF}_3$  respectively, as follows: (x) 3.75, 1.25 ; (♦) 2.50, 2.50 ; (○) 7.50, 2.50 ; (◇) 15.00, 2.00 ; (+) 1.25, 3.75 ; (▲) 11.25, 3.75 ; (■) 5.00, 5.00 ; (●) 2.50, 7.50 ; (□) 7.50, 7.50 ; (Δ) 3.75, 11.25 ; full lines equation (6).

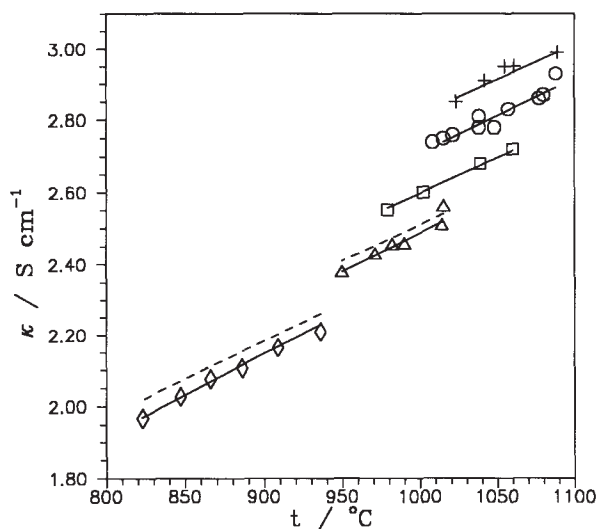

Figure 11: The electrical conductivity of  $\text{Na}_3\text{AlF}_6$  -  $\text{AlF}_3$  -  $\text{Li}_3\text{AlF}_6$  mixtures as a function of temperature; compositions in wt%  $\text{AlF}_3$  and wt%  $\text{Li}_3\text{AlF}_6$  respectively, as follows: (+) 0, 0 ; (○) 3.55, 3.40 ; (□) 7.56, 7.30 ; (Δ) 12.18, 11.73 ; (◇) 17.50, 16.86. Full lines - equation (5); dashed lines - equation (5) without cross term.

of the mole fractions of  $\text{Li}_3\text{AlF}_6$  and  $\text{AlF}_3$  exceeds 0.15 (see Fig. 11).

The addition of  $\text{KF}$  to cryolite lowers the conductivity slightly, as shown in Fig. 5. In the ternary system  $\text{Na}_3\text{AlF}_6$  -  $\text{AlF}_3$  -  $\text{KF}$  a strong negative effect of  $\text{AlF}_3$  prevails, as shown in Fig. 10. The term representing component interaction is insignificant in the investigated concentration range. Potassium fluoride is not a common additive to the electrolyte of aluminium cells because it intercalates with carbon, causing severe swelling and disruption of the cathode lining [30], but in the future, using inert electrode materials, it may become important.

#### Multicomponent mixtures

Modified baths for electrowinning of aluminium may contain  $\text{MgF}_2$  and  $\text{CaF}_2$  in addition to  $\text{LiF}$  and excess  $\text{AlF}_3$  [3]. A certain concentration of  $\text{CaF}_2$  (3 - 6 wt %) will always build up due to the content of calcium oxide in the alumina feed.

According to the proposed model the conductivity of a multicomponent system can be described by an equation of the type

$$\begin{aligned} \kappa / \text{Scm}^{-1} = & 7.22 \exp(-1204.3 / T) - 2.53[\text{Al}_2\text{O}_3] \\ & - 1.66[\text{AlF}_3] - 0.76[\text{CaF}_2] \\ & - 0.206[\text{KF}] + 0.97[\text{Li}_3\text{AlF}_6] \\ & - 1.07[\text{MgF}_2] - 1.80[\text{Al}_2\text{O}_3][\text{CaF}_2] \\ & - 2.59[\text{Al}_2\text{O}_3][\text{MgF}_2] \\ & - 0.942[\text{AlF}_3][\text{Li}_3\text{AlF}_6] \end{aligned} \quad (8)$$

where  $T$  represents the temperature in K and the brackets represent the mole fractions of the additions, or by the equation

$$\begin{aligned} \ln \kappa = & 1.977 - 0.0200[\text{Al}_2\text{O}_3] - 0.0131[\text{AlF}_3] \\ & - 0.0060[\text{CaF}_2] - 0.0106[\text{MgF}_2] \\ & - 0.0019[\text{KF}] + 0.0121[\text{LiF}] - 1204.3 / T \end{aligned} \quad (9)$$

where  $T$  represents the temperature in K and the brackets represent the concentration of additives in wt%. This equation is less precise (maximum relative error less than 2.5%) than equation (8). In this case the cross terms in equation (8) are not included, because they turned not to be statistically significant.

The meaning of the first term in equation (8) was discussed above. The subsequent six terms represent the influence of additives on the electrical conductivity as follows from the additivity rule. It was found that the experimental conductivity data obtained for mixtures containing  $\text{MgF}_2$  and/or  $\text{CaF}_2$  were less precise than the data obtained for the system  $\text{Na}_3\text{AlF}_6$  -  $\text{Li}_3\text{AlF}_6$  -  $\text{AlF}_3$  ( $\text{KF}$ ). The same behaviour was observed in the investigation of the binary mixtures [6]. As mentioned above this may be caused by changes in the wetting of the boron nitride tube or by the influence of the additives on the electrode reactions taking place at the electrodes. Conductivity data for several compositions are summarized in Table III.

Oblakowski [31] measured electrical conductivities for five cryolite based melts having a constant excess of 9.1 wt %  $\text{AlF}_3$  and additions of  $\text{Al}_2\text{O}_3$  (2 and 4 wt %),  $\text{CaF}_2$  (4 and 6 wt %),  $\text{MgF}_2$  (2 and 4 wt %), and  $\text{LiF}$  (2 wt %). These data are low by  $0.1 \text{ S cm}^{-1}$  in comparison with equations (8) and (9). Since this deviation is constant, one may assume that it could be caused by a systematic error.

Table III Experimental and calculated values of electrical conductivity of cryolite-based melts related to the temperature of 1000 °C

additive / wt%					$\kappa$ / S cm <sup>-1</sup>		
AlF <sub>3</sub>	Li <sub>3</sub> AlF <sub>6</sub>	MgF <sub>2</sub>	CaF <sub>2</sub>	Al <sub>2</sub> O <sub>3</sub>	exper.	calc. eqn. (8)	Wang et al.[7]
3.90	3.75	4.16	-	-	2.62	2.58	2.60
8.37	8.07	4.47	-	-	2.48	2.48	2.54
-	10.86	4.02	-	-	2.84	2.80	2.80
-	22.45	4.15	-	-	2.95	2.92	2.95
12.31	-	-	2.75	-	2.40	2.34	2.42
-	22.45	4.15	-	-	3.00	2.92	2.95
-	24.61	4.55	5.70	-	2.73	2.83	2.87
-	25.26	4.25	5.80	2.53	2.75	2.72	2.75
12.17	11.72	-	-	1.98	2.40	2.40	2.53
-	-	3.00	3.00	3.00	2.51	2.50	2.54
-	-	6.00	3.00	3.00	2.42	2.42	2.47
-	-	3.00	6.00	3.00	2.46	2.46	2.51
-	-	5.00	5.00	5.00	2.31	2.33	2.39

In Table IV the coefficients in the equations due to Choudhary [11] and to Wang et al. [7] are compared with those of the present work. Although the general agreement is fair, there are some discrepancies in individual coefficients, especially for MgF<sub>2</sub> and LiF.

In most cases there is good agreement between conductivities derived from the equation due to Wang et al. [7] and conductivities predicted by equation (8), as shown in Table III. The Table also illustrated the slight discrepancies between the experimental data and equation (8).

In general the electrical conductivities of multicomponent mixtures evaluated by equation (8) are closer to the conductivities evaluated by the equation of Wang et al. [7] than to that of Choudhary [11].

Table IV. Comparison of coefficients in regression analysis equations

Coefficients	Choudhary eq.(1)	Wang et al. [7]	This work eq.(9)
Constant	2.0156	1.9362	1.977
%Al <sub>2</sub> O <sub>3</sub>	-0.0207	-0.01755	-0.0200
%CaF <sub>2</sub>	-0.0049	-0.00413	-0.0060
%MgF <sub>2</sub>	-0.0166	-0.00398	-0.0106
%KF	-	-	-0.0019
%LiF	0.0178	0.00812	0.0121
%AlF <sub>3</sub>	-	-	-0.0131
Temp. coeff.	-2068.4	-1751.1	-1204.3
Bath ratio	0.4349	0.3092	-

References

1. K. Grjotheim, C. Krohn, M. Malinovsky, K. Matiasovsky and J. Thonstad, Aluminium Electrolysis - Fundamentals of the Hall-Heroult Process (Düsseldorf, Aluminium-Verlag, 2nd ed., 1982).
2. J. Thonstad and A. Solheim, Aluminium, 62 (1986), 939.
3. K. Grjotheim, H. Kvande and B. J. Welch, Proc. TMS - AIME, Light Metals 1986, p.417.
4. Å. Sterten, S. Rolseth, E. Skybakmoen, A. Solheim, and J. Thonstad, Proc. TMS -AIME, Light Metals 1988, p.663.
5. X. Wang, R. D. Peterson, and A. T. Tabereaux, Proc. TMS - AIME, Light Metals 1992, p.481.
6. P. Fellner, O. Kobbeltvedt, Å. Sterten, J. Thonstad, Electrochim. Acta 38 (1993), 589.
7. X. Wang, R.D. Peterson and A.T. Tabereaux, Proc. TMS-AIME, Light Metals 1993, p.247.
8. P. Fellner, S. Midtlyng, Å. Sterten, J. Thonstad, J. Appl. Electrochem. 23(1) (1993), 78.
9. K.B. Kim, D.R. Sadoway, J. Electrochem. Soc. 139 (1992), 1027.
10. G.J. Hills and S. Djordjevic, Electrochim. Acta 13 (1968), 1721.
11. G. Choudhary, J. Electrochem. Soc. 120 (1973), 381.
12. J. Thonstad, S. Jarek, T. Müftüoğlu, P. Godet and R. Ødegård, Proc. Int. Symp., on Reduction and Casting of Aluminium and Other Light Metals (New York, NY: Pergamon Press, 1987), 219 - 228.
13. G. D. Robbins, J. Electrochem. Soc. 116 (1969), 813.

14. R.P.T. Tomkins, G.J. Janz and E. Andalaft, J. Electrochem. Soc. 117 (1970), 906.
15. G.J. Janz, J. Phys. Chem. Ref. Data 17 (1988), Suppl. 2, 232.
16. P. Fellner, K. Grjotheim and H. Kvande, J. Metals, 37 (1985), 29.
17. J.D. Edwards, C.S. Taylor, L.A. Cosgrove, A.S. Russell, J. Electrochem. Soc. 100 (1953), 508.
18. K. Matiasovsky, M. Malinovsky, S. Ordzovensky, J. Electrochem. Soc. 111 (1964), 973.
19. E.W. Yim and M. Feinleib, J. Electrochem. Soc. 104 (1957), 626.
20. G.A. Abramov, M.M. Veyukov, I.P. Gupalo, A.A. Kostyukov and L.N. Lozhkin, Teoreticheskie osnovy elektrometallurgii alyuminiya (Moscow: Metallurgizdat, 1953), 158-175.
21. K. Matiasovsky and V. Danek, Unpublished results, cited in ref. [1].
22. G.J. Janz and R.P.T. Tomkins, Physical Properties Data Compilations Relevant to Energy Storage, IV. Molten Salts: Data on Additional Single and Multi-Component Salt Systems, (Washington, U.S. Government Printing Office, 1981).
23. R. D. Peterson, Proceedings of Electrolyte Workshop, Light Metal Production Group, Carnegie-Mellon Univ., Pittsburg (1986).
24. M.A. Kuvakin, T.D. Vol'khina and L.M. Kuvakina, Tsvetn. Met. 44(7) (1971), 33.
25. V. Danek, M. Malinovsky and K. Matiasovsky, Chem. zvesti 22 (1968), 707.
26. G.A. Abramov, A.A. Kostyukov, L.V. Nordvik, Trudy Lening rad. Politekhn. Inst. 188 (1957), 40.
27. A.I. Belyaev, Elektrolit alyuminievykh vann, (Moscow, Metallurgizdat 1953), 48.
28. E. Vatslavik and A.I. Belyaev, Zh. Neorgan. Khim. 3 (1958), 1044.
29. E. Skybakmoen, A. Solheim, and Å. Sterten, Proc. TMS - AIME, Light Metals 1990, p.317.
30. K. Grjotheim, B.J. Welch, Aluminium Smelter Technology, (Düsseldorf, Aluminium-Verlag, 1980), 34.
31. R. Oblakowski, Rudy i Metale Niez lazne 32(10) (1987), 379.
32. A. Vajna, Alluminio 19 (1950), 215.