

STUDY OF MANUFACTURING TECHNOLOGY FOR HIGH QUALITY ANODES

Zhao Qingcai, Zhao Jingli, Zhao Qingbo
Jinan Aohai Carbon Corporation Ltd. ; Pingyin, Jinan, Shandong Province, China 250403

Keywords: high quality anodes, GPC, blending, aggregate recipe, pressure vibration forming, advanced baking system

Abstract

Based on R&D for the GPC from the different areas in China and anode manufacturing process a series of high quality anode manufacturing technologies are developed and shown in this paper, such as blending of GPC with different properties and element distributions, aggregate and high density paste recipe, pressure vibration forming and advanced baking system etc. By application of the mentioned above technologies the bulk density, conductivity and CO₂ reactivity are greatly improved for high quality anode manufacturing. And the production technology of the complex configuration and structure anodes are developed and put into operation.

Introduction

Anode quality is of great importance to aluminum reduction for the energy saving and emission reduction. The aluminum reduction process stability and current efficiency can be improved by using high quality anodes for lower carbon dusting and overheat.

With the rapid development of the world aluminum industry the quality of GPC, the major raw material used in anode manufacturing is reducing, as the result of which the anode manufacturers have to produce anodes from lower grade and high sulfur GPC. Therefore development of the technology to produce high quality anodes from lower grade GPC becomes an important R&D project for modern anode industry.

Jinan Aohai Carbon Corporation Ltd. (Aohai), one of the major anode companies in China has developed and applied the high quality anode manufacturing technology by R&D for many years including blending of GPC from various resources, dry aggregate recipe of middle size CPC, mixing of high density paste, high pressure vibration forming, advanced baking systems. Aohai has exported a great amount of high quality anodes to USA, Australia and Middle East etc with high anode density, conductivity and excellent reactivity and becomes a major high quality anode supplier in China.

The details of the high quality production technology and the roadmap for energy saving and emission reduction in the anode manufacturing in Aohai company are described in this paper.

GPC Calcination and Aggregate Recipe

GPC Blending

Based on the R&D results of Prof. Liu Fengqin and R&D Carbon on the Chinese GPC properties the quite different minor elements distribution and reactivity for the GPC's from the oil refineries in the North-east area, around Bohai sea, Middle and South area and

North-West area in China are revealed. And there is existing a complementarity among the GPC's so that a blending technology using the GPC from the different areas refineries can be applied. The high quality anodes can be produced from the mixed GPC blended by the possibly below grade or unqualified GPC's .

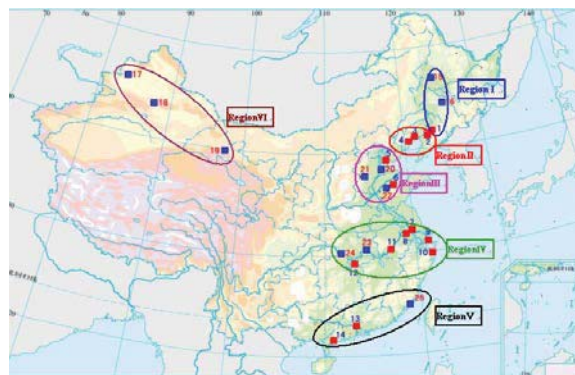

Fig.1 6 GPC Areas with Different Properties in China

The GPC blending technology is the most important basis for Aohai to keep high anode quality and an available process to use the lower grade GPC. The blending process includes setting up the GPC storage areas for different GPC resources and blending system according to the blending target from the different GPC's with their volatiles and dust content, minor elements and size distributions

Modern CPC Shaft Calciners

The modern shaft calcination technology has been developed in Aohai company for improving CPC quality, energy saving and emission reduction mainly including the shaft calciner structure design, the energy recovery and desulfurization process of the calciner high temperature gas.

The modern calciner system is composed of CPC automatic and accurate feeding, high productivity shaft calciner system, automatic and closed discharger, heat recovery boiler from the flue gas and power generator and gas desulfurization system.

Based on the systematic R&D a new structure of the modern shaft calciner has been designed for the better volatiles overflow, air combustion in the new structured flues and cooling systems etc for the completed combustion of volatiles and excellent temperature control. The lining materials with ideal properties are selected for lining quality and longer operation life. The advanced automatic and mechanized technologies are applied for automatic blended GPC feeds and CPC discharging for better operation circumstance and labor intensity.

The major advantages of the modern shaft calciners: 1) higher heat efficiency without extra fuel addition; 2) the volatiles are heated and decomposed on CPC surfaces for better CPC strength; 3) less carbon burning due to better airtight of the shaft calciners, only 2%-5%; 4) the retention time of CPC in the calciners can be controlled for CPC quality uniformity.

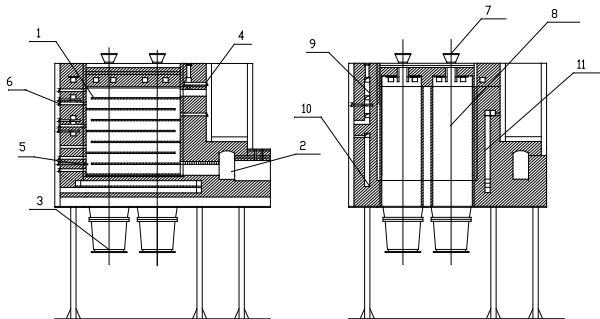

Fig.2 Basic Structure of Shaft Calciners

A modern, large-scale and green GPC shaft calciner is installed in Aohai with a pot capacity of 160 kg/hr and a calciner capacity (72 pots) of 100 kt, which is closed to a common rotary kiln.

The CPC quality has been greatly improved by using Aohai's modern shaft calciners, especially the real density and conductivity. Table 1 shows the major advantages of the technology.

Table1 Comparison Between Old and Modern Shaft Calciners

Calciners	Cpacity kg/pot hour	Real Density g/cm ³	Conductivity μΩ·m
Old Types	70-80	2.02-2.05	530-600
Modern Types	140-160	2.06-2.10	420-470

High Quality Anode Manufacturing Technology

A series of tests in all key stages in the anode manufacturing process have been carried out for producing high quality anodes in Aohai. The tests process is shown in the Fig. 3.

Optimized Aggregate Recipe with Middle Sizes

An aggregate recipe with a middle sizes has been developed in Aohai for the biggest dry aggregate density, which is obtained by tests.

The fines are composed of the fines from raw material, e.g. CPC, from balling mills and dusts recovered etc. The fines occupy about 40% of mass in the dry aggregates and have more than 90% of total surface area so that the accurate addition percentage of the fines plays important role for the anode quality.

The fine addition is controlled by the Bulling tests results in Aohai for higher anode density and strength and lower porosity.

The R&D results show that addition of the fine and coal tar pitch should be as less as possible for lower air permeability only if the targets of other properties could be achieved.

The optimization study for the 4 size dry aggregates recipe in Aohai has been carried out by the orthogonal experiments and the CPC particle sizes, aggregates composition and fine addition are regulated and improved for high density, low porosity and air permeability of the dry aggregates.

High Density Paste Preparation

A high density paste has been prepared in Aohai for improving the paste density. The technology aim at the uniform distribution of coal tar pitch on all the particle surface including the fines without any rest area or over addition of the pitch. In the meantime the pitch addition should be added as less as possible for lower air permeability providing qualified bulk density.

The test results show that pitch addition percentage should be in a suitable range for a recipe. When more pitch is added a lower anode bulk density and higher air permeability would be achieved due to too much burning loss during baking. But too low pitch addition would bring about lower green anode bulk density, which leads higher anode porosity and permeability. So the high bulk density and lower permeability of the anodes can be achieved by a suitable pitch addition.

The optimized pitch addition is selected in the range of 15.6%-16.5% in Aohai by the tests of pitch addition and all the analysis results of the final product properties. As a result the Aohai's anodes obtain a high quality.

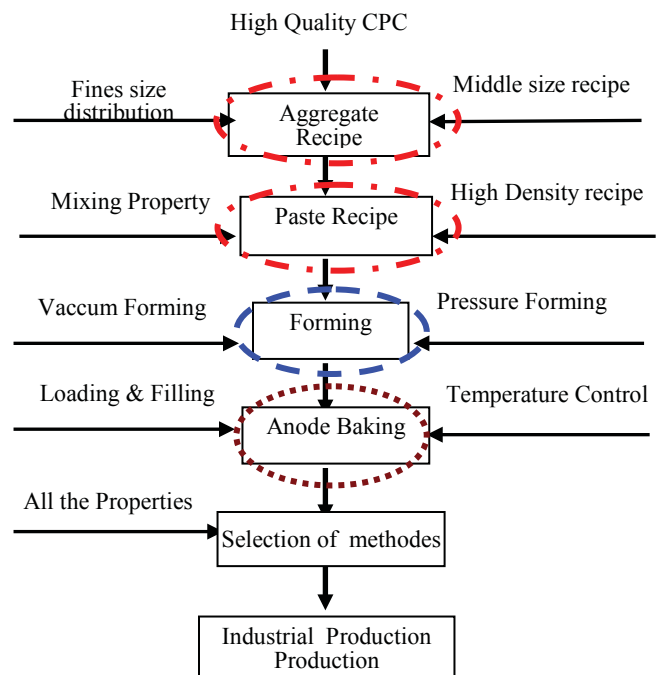

Fig 3 Test Process for High Quality Anodes

Forming Process for High Quality Anodes

Tests results revealed that some high pressure bubbles would form inside paste during vibration forming process and possibly expand when vibration is completed, which would lead to the crack formation in upper region, side portion or inside in the green anode and lower qualified product percentage.

The crackles could be removed by high pressure and vacuum vibration forming. The forming process applies the pressure vibration as high as 9-11 MPa so that the green anodes can be compressed uniformly under high pressure and the air in the bubbles can be taken out under the vacuum circumstances as well.

As the result the bulk density of the green anodes could reach more than 1.66 g/cm³, which provides the basis for producing high quality anodes.

Baking Process for High Quality Anodes

Baking is the key process in the anode manufacturing, in which the baking furnaces and special control systems are applied for improving anode quality and energy saving. Uniformity of baking temperatures, optimization of temperature rising and the final baking temperature are the major baking purposes, which can be achieved by an excellent baking control system.

In order to improve anode quality, reduce energy consumption and extend baking furnace operation life the optimization of the ring furnace structures have been carried out by Aohai. An excellent control system for firing device, negative pressure, improving flue temperature set up and the operation parameters has been developed for keeping the temperature distribution in the flues and pots and differences in a reasonable range.



Fig 4 New Firing Control System

The heating curves are optimized by math models in Aohai. It is found by a series of industrial tests and data analysis that in the original baking furnaces only a few thermocouples are used for temperature control, which can not reveal fully the temperature distribution in the furnaces.

A new baking furnace temperature monitoring and control system is developed by Aohai due to analysis of the temperature test data in the furnaces. The uniformity and stability of temperature in the baking furnaces are greatly improved by applying the new control system to ensure the anode quality and the qualified product rate.

By developing and applying a series of technology the anode quality in Aohai has been greatly improved, especially such key properties as the anode bulk density, CO₂ reactivity and air permeability etc., which promotes great export of Aohai's anodes. And Aohai becomes a major anode supplier with the highest product quality level in China.

Table 2 shows that the major technical indexes of the anode products from Aohai are much better than the Chinese common standards.

Table 2 Quality Comparison between Aohai and Common Chinese Standards

Technical Goals	Bulk Density g/cm ³	CO ₂ Reactivity	Air Permeability nPm
Aohai	1.58-1.60	≥90%	1.5-2.0
Common Standards	≥1.50	≥80%	≤3.5

Table 3 shows that by applying the new type anode baking furnaces in Aohai the natural gas consumption for anode baking has been reduced by more than 50% and only about 50 m³ of natural gas are consumed for one ton of anode.

Table 3 Natural Gas Consumption Comparison

Furnace Type	Months			
	1	2	3	average
Old Types	105	105.3	104	105
New Types	50.3	51	49.3	50
Energy Saving	52%	51.6%	52.6%	52.4%

Summary

Based on a significant number of tests by Aohai the GPC Blending from different resources, Modern GPC Shaft calciners, Optimized Dry Aggregates Recipe, High Density Paste Preparation and Efficient and Energy Saving Baking technologies are developed and applied in Aohai. And Aohai greatly improves anode quality and exports its anode overseas.

The heat in the waste gas during GPC calcination is recovered and a great benefit is achieved by Aohai. The baking energy consumption is greatly reduced by full burning of the volatiles in pitch and reducing heat dissipation of baking furnaces in Aohai's anode manufacturing. Aohai has become the pioneer to develop technologies and is a successful high quality anode supplier.

References

- [1] Liu Fengqin “Chinese Raw Materials for Anode Manufacturing” R&D Carbon Ltd. 2004
- [2] Zhao Jingli “The New Generation of Vertical Shaft Calciner Technology” Light Metals 2011 p.917-922
- [3] L. Edwards “Quality and Process Performance of Rotary Kilns and Shaft Calciners” Light Metals 2011 p.895-900
- [4] Xu Haifei et al. “Baked Anode Quality Improvement Through Optimization of Green Anode Processing” Light Metals 2012 p.1169-1172
- [5] B. Ndjom et al. “Improving Baked Anode Density and Air Permeability Through Process Optimization and Coke Blending ” Light Metals 2013 p.1105-1110
- [6] Raja Jeved Akhtar, Markus W. Meier et al. “Anode Quality and Bake Furnace Performance of EMAL” Light Metals 2012 p.1175-1179