

Light Metals 2014

ALUMINA AND BAUXITE

Cost Reduction/ Alumina Recovery

SESSION CHAIR

Roberto Seno Jr.

Votorantim Metais/CBA

Aluminio, Brazil

A Review of Two Phase Flow Modeling and Its Applicability to the Bayer Process

Alessio Scarsella¹ Hans-Werner Schmidt¹
¹Outotec GmbH, Ludwig Errard – Strasse 21.

Keywords: Digestion, Flash Tanks, Pipework

Abstract

The premature failure of interconnecting flash tank piping in the Bayer Process costs the industry millions each year in replacement of materials and downtime of process equipment. The underlying driving force of the recuperative heating unit of a digester is that slurry at saturation conditions is counter currently de-pressurized and cooled along the saturation curve by means of stage wise flash evaporation. The movement of a near boiling slurry between flash tanks requires careful consideration as vapour forms whilst the slurry slowly de-pressurizes due to in pipe frictional losses and net changes in momentum energy as the fluid pressure falls below the vapour pressure. The failure to interpret the specific points at which large rises in *pipe* velocity due to a change in phase can result in mis-interpretations in design which in turn result in accelerated pipe erosion and eventual rupture with implications to operations, health and safety.

Introduction

A vast array of technologies and process arrangements have been employed for the caustic dissolution of aluminum bearing minerals in bauxite, some of these technologies will digest bauxite at atmospheric conditions others at high pressures (up to 70 Bar). In order to maximize heat recovery in the incoming streams of caustic liquor and bauxite slurry (or both) are counter currently heated with flash vapor from allocated flash tanks. Because slurries being maintained above their flash conditions by means of appropriate valving any sudden drop in pressure below saturation will result in a phase change and vapour formation, hence as the slurry moves from flash tank to flash tank (finally to atmospheric pressure) the slurry will be on the ‘*cusp*’ of the saturation conditions.

The Nature of Interconnecting Flash Tank Pipe work

Hydraulic residence in the flash tank pipe work implies that the static head in the upstream flash tank is equal to the net elevation change plus the frictional and acceleration losses. Due to the design of the recoverable heating section in digestion, the net hydraulic and thermal losses as the slurry travels from flash tank to flash tank are in equilibrium (or in proximity to). The static head generated in the upstream flash tank ensures single phase continuity of the slurry, however frictional losses will ensure that as the slurry makes it’s downstream it will flash at a lower elevation than the slurry level at the upstream tank (Figure 1). Regardless of pipe work geometry this condition is guaranteed, however as the slurry progressively loses pressure and drops below the saturation point of the liquor the more vapor will be generated and result in a lower combined density with higher homogenous average slurry/vapour velocities. These high velocities combined with the presence of the solid phase in the form of red mud can result in premature pipe work failure resulting in containment and safety related issues.

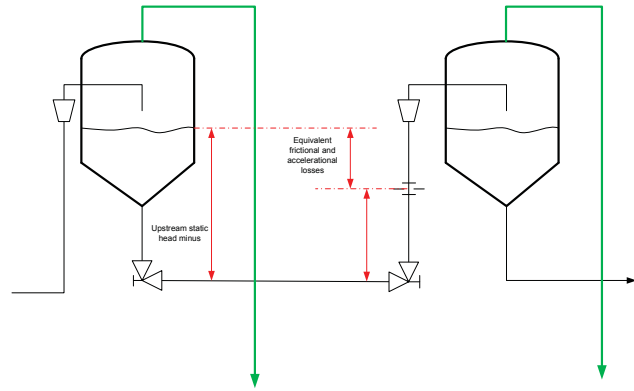

Figure 1: Illustration of hydraulic resistance and upstream flash tank level equilibrium for digestion flash tanks

Poorly designed flash tank pipe work could result in erroneous interpretation of phase change resulting in higher than desirable velocities for the vapor slurry mixture. This can result in high velocity impact of particles and liquid droplets causing erosion and pipework wear. The qualitative pseudo erosion versus angle of impingement on a ductile material such as (carbon) steel is depicted in Figure 2. This shows that for a given velocity at a particular angle of impingement the rate of erosion can vary widely. The rate of erosion with solid laden flows depends on; i) the number of particles either striking or shearing a surface, ii) the impact angle and iii) whether the pipe is either ductile or brittle. The results below demonstrates that, if given sufficient velocity, ductile materials such as carbon steel pipe will erode even at low solids impact angles.

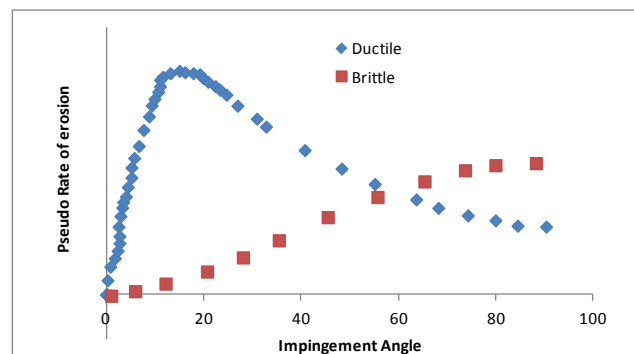

Figure 2: Rate of erosion of ductile and brittle materials subject to high velocity solids impact [1]

Figures 3 and 4 are examples of high rates of erosion experienced with solids on carbon steel with a low level of angle of impingement, highlighting some of the devastating effects that can incur with uncontrolled wear.



Figure 3: Example 1 of erosion due to high velocity solids flow [2]

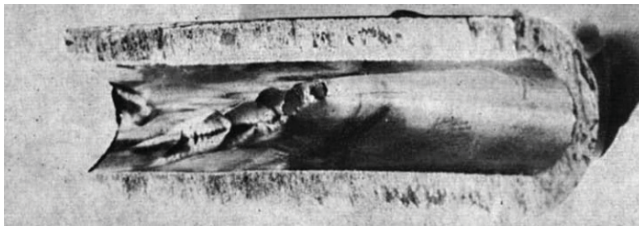

Figure 4: Example 2 of erosion due to high velocity solids flow [2]

The presence of flashing slurry mixtures in straight pipes will result in the presence of multiphase flow regimes. Such regimes have been defined by in the literature for horizontal [3] vertical pipes [4]. Figure 5 and Figure 6 illustrate experimentally determined flow regimes for gas-liquid flow in horizontal and vertical pipe segments respectively. Such principles can also be applied to flashing slurries as witnessed in digestion.

In flash tank pipe work there are four flow regimes that are of interest:

1. **Elongated bubble:** On the inception of flashing in the pipe work, bubbles will nucleate on both pipework and solid particle surfaces. The flow regime is intermittent and inconsistently distributed radially around pipe flows with bubbles sporadically agglomerating and collapsing.
2. **Slug:** Slug flow is the extension of the Elongated bubble regime whereas the size of the vapor bubbles and pockets formed are larger and more consistent, although not uniformly distributed, this regime can result in pipe wear even in straight sections, as sections of pipe will be exposed to uniform impingement of vapor and slugs of slurry.
3. **Churn:** Churn flow is similar to slug is however disorderly and applicable to vertical sections of pipe only, it is in appearance similar to slug flow however the liquid slugs are cyclically falling and forming high pressure beds which then burst further up the pipe as the pressure in the gas/vapor pockets builds up.
4. **Annular Flow:** This regime is characterized by the gas/vapor phase in the central core of the pipe, with the liquid/slurry phase forming a uniformly dispersed film around the circumference of the pipe.

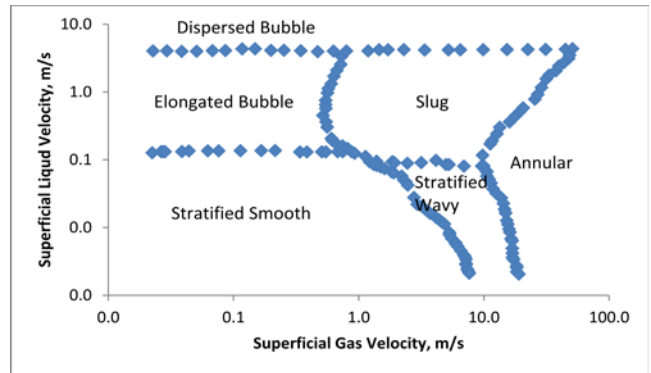

Figure 5: Horizontal Pipe flow regime map [3]

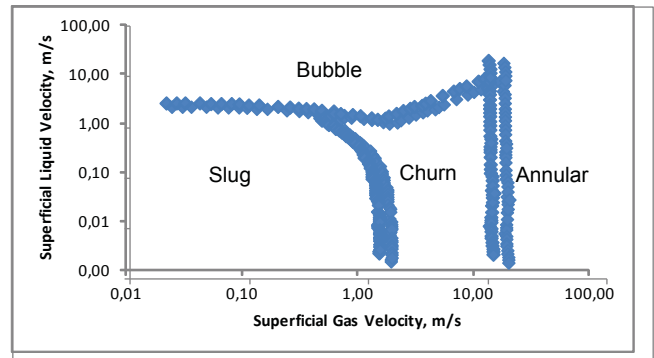

Figure 6: Vertical Pipe flow regime map [4]

Due to extremely high Reynolds numbers encountered in flash tank pipe work, the extent of the vapour (gas) phase and dilute presence of solids, the establishment of a particular flow regime as the slurry exits a fitting to a straight section of pipe is rapid. However the flow regime descriptions and maps illustrated in Figures 5 and 6 are not applicable when the flow encounters a bend, tee, valve or any irregular boundary flow condition which will yield a non – uniform velocity profile. Figures 7 and 8 are a depiction of the single phase velocity profile and streamlines of flow through a 90 degree bend and 90 degree tee (branch). The presence of a second phase will not hinder the presence of such velocity profiles and flow structures; however the absolute velocities encountered are higher, meaning that the outer sections of the bend or tee branch are subject to wear.

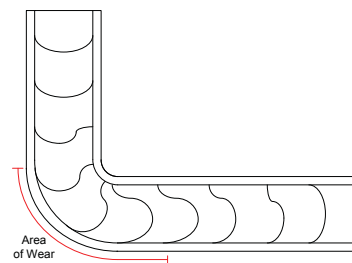

Figure 7: Illustration of velocity profile and area of wear around a 90 degree bend

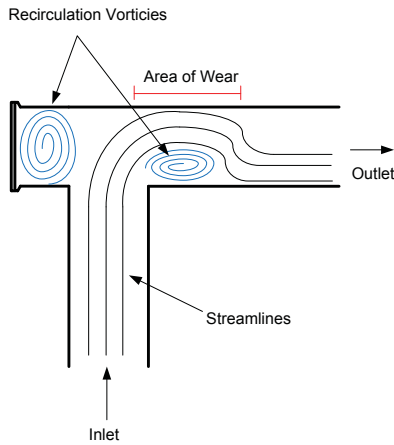

Figure 8: Illustration of streamline, vortex formation and area of wear in a tee branch

The economic impact on maintenance and operational costs

There are two facets to the economic impact on high wear in interconnecting flash tank pipe work

- 1) The capital cost of continuous replacement of spares
- 2) Down time of process equipment.

The replacement of tees, bends and valves are costly and can result in the tens of thousands (USD) per fitting replacement; however the true economic loss is the downtime of process equipment. In the event that flash tanks are by-passable this can vary from one to two days to more than a week, (depending on the availability of spares and the time required isolating a single flash tank using grindable angle valves). Operating with one or two less flash tanks results in thermal penalties, such as an increase in steam consumption and drop in condensate production. Table 1 is a summary of process simulations using the Outotec refinery Syscad model using a single stream high temperature digester¹ digesting boehmitic bauxite. This table shows the thermal effects of losing one or two flash tanks could mean an increase in steam consumption from 5.8 % to 12.9 %. Depending on the actual design allowance of the steam generation plant this could have a negative impact on production if more than two flash tanks are taken offline due to pinhole leaks. In addition the capability of the digestion plant to generate condensate which needs to be reconciled in evaporation thus requiring more energy.

	Baseline	1 Flash tank off	2 Flash tanks off
Calculation specific energy consumption Digestion, GJ/t	2,39	2,53	2,70
Specific Steam Consumption, t/t	1,50	1,59	1,71
Specific Condensate Production, t/t	3,73	3,68	3,62
% Increase in steam consumption		5,8%	12,9%

Table 1: Process effects of one and two flash tanks inoperative

¹ Hatch – Outotec Joint Venture (HOT JV) are the joint proprietary owners of single stream jacketed pipe unit digestion technology.

In a more extreme case if the ability to bypass single flash tanks is not incorporated into digester design then the plant may face an entire digestion unit plant outage resulting in serious loss of production.

Modeling and prediction of inter-flash tank pipe work behavior and strategies to mitigate high wear

Multiple relationships for the Hydraulic prediction of gas/vapor and liquid flows exist.

The building blocks for hydraulic pressure losses are the combination of static, friction and change in momentum:

$$\frac{dP}{dz_{Total}} = \frac{dP}{dz_{Static}} + \frac{dP}{dz_{Momentum}} + \frac{dP}{dz_{Frictional}} \quad \text{Equation 1}$$

This can be then expanded to the following semi empirical relationship:

$$\frac{dP}{dz} = \rho_H \sin \varphi + \frac{d(G^2/\rho_H)}{dz} + 2\phi \frac{f G^2}{D \rho_H} \quad \text{Equation 2}$$

Where $\frac{dP}{dz}$ is the pressure gradient, φ the angle of pipe inclination, ϕ is the two phase flow multiplier [5,6,7], G is the mass flux, f is the fanning friction factor, D , pipe diameter and ρ_H is the homogenous density of the vapor and slurry phases combined. This final term is estimated as follows:

$$\rho_H = \rho_L(1 - \varepsilon) + \rho_g \varepsilon \quad \text{Equation 3}$$

Where ε is the vapor void fraction of the mixture and ρ_L , ρ_g are the liquid and vapor phase densities. The vapor void fraction is then defined as:

$$\varepsilon = \frac{1}{1 + \left(\frac{u_g(1-x)\rho_g}{u_L x \rho_L} \right)} \quad \text{Equation 4}$$

Where x is the vapor fraction by mass and u_g , u_L are the vapor and liquid phase superficial velocities. It is the ratio of the latter $\frac{u_g}{u_L}$ which is referred to as the slip ratio. It is clear than under certain flow regimes (annular) those velocities for the vapor and liquid phase will vary, particularly in a straight length of pipe. A slip ratio of 1, is indicative of homogenous vapor liquid flow, however other correlations (or several compilations thereof) do exist for other flow regimes where there is a distinct boundary condition between the vapour and liquid phases [8, 9, 10] and such correlations have been used in digestion to the benefit of the Bayer Industry [11,12].

By using the above relationships and the process conditions highlighted in Table 2 three design scenarios were studied.

Flash Tank Conditions		
		Units
A/C	0,75	
Caustic	262	g/L, Na ₂ CO ₃
C/S	0,87	
Temperature	128	°C
Slurry Density	1327	kg/m ³
Pressure Upstream Flash Tank	193,00	kPa
Pressure Down Stream Flash Tank	137	kPa
Flow rate	1173	kL/h

Table 2: Proposed flash tank process conditions for two phase flow modeling and level estimation

Three different pipe work geometries (Figure 9) were evaluated using Equation 2 with the homogenous slip ratio assumption. Figure 9 A), B) and C) show qualitatively the three different conformations, all of which are top entry, A) and B) are characterized by an expansion in the straight vertical section leading to the downstream flash tank whereas C) is characterized by two expansions firstly at the straight vertical section and then on the horizontal section inside the downstream flash tank itself. The three designs are also characterized by the presence of a restriction orifice post expansion in the vertical straight sections, for the purpose of this exercise the size of the restriction orifice was manipulated so that an upstream level of 2.9 meters was conserved.

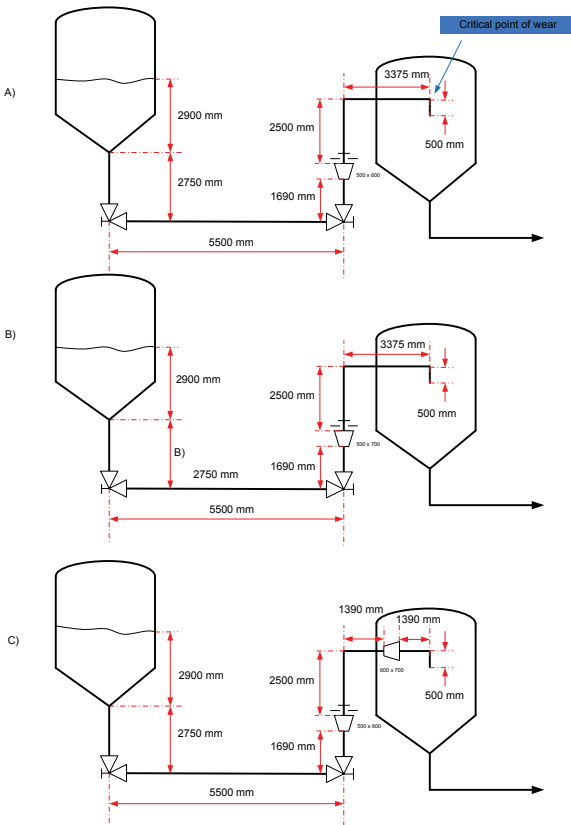

Figure 9: Flash tank pipe work designs A, B and C

The upstream and downstream process conditions between each flash tank is strictly governed by the thermodynamics of the digestion unit (boiling point elevation, heat transfer coefficients and heater areas, etc), the progressive conditions from the start and end points are governed by the hydraulics. Figure 10 is the comparisons of pressure profile versus cumulative pipe length for all three designs for the same inlet and outlet conditions. The pressure profiles show an identical profile prior to flashing with their magnitude being characterized by the upstream level in the flash tank. Designs B and C show very similar characteristics once flashing is occurring (further upstream), whereas for design A flashing occurs further downstream. Conversely, to meet the same start and end point conditions the pressure gradient just before the discharge point is comparatively higher for design A.

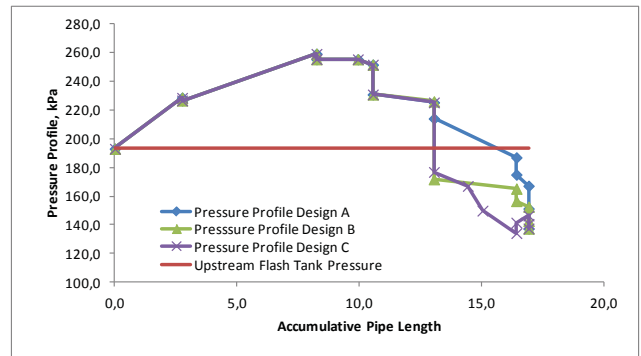

Figure 10: Flash tank pressure profile for Designs A, B and C.

Figures 11-13 highlight some of the calculated data retrieved from the two phase flow modeling for all three designs, namely the average velocity and vapor fraction profiles versus cumulative fitting type. The translation of such results into robust designs that withstand wear and erosion lie within the practical interpretation of average velocities of the two phase mixture which in turn are dictated by the vapor fraction profile. High average velocities of the two phase mixture will also result in even higher local velocities when encountering non-symmetrical velocity profiles for various fittings such as those illustrated in Figure 7 and Figure 8. This makes such fittings more susceptible to wear and erosion. A comparison of the two last tee branches for all three designs shows that the average velocity of each increases from 5.8 and 14.9 m/s (Figure 11) to 11.6 and 17.2 m/s (Figure 12) to 15 and 20.3 m/s (Figure 13) for designs A), B) and C) respectively. From the above results it can be concluded that design A is the more appropriate choice as the sharp changes in direction from the tees will be less susceptible to wear.

Use of the flow regime maps in Figure 5 and Figure 6 suggest that on the inception of flashing that slug conditions are encountered in the straight sections of pipe (Figures 11-13). In all three cases this is occurring at the horizontal section of pipe prior to flash tank discharge.

In addition to the improvements to pipe work design and decision making of upstream flash tank levels, the results of the modeling will suggest where the areas of high wear are encountered hence further preventive measures for these areas such as hard facing or white iron inserts can be considered.

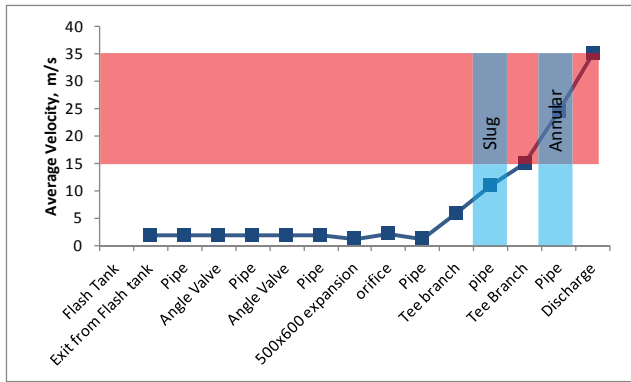

Figure 11: Average velocity profile Design A

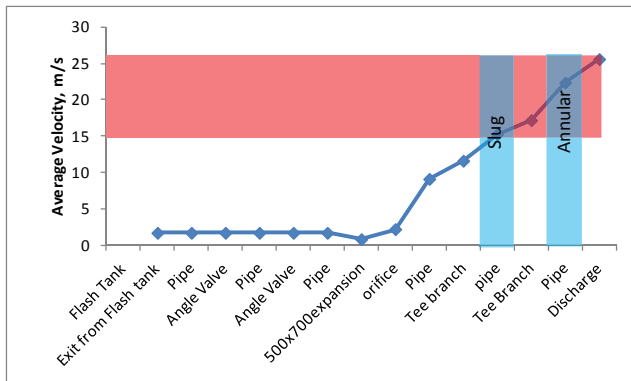

Figure 12: Average Velocity Profile Design B

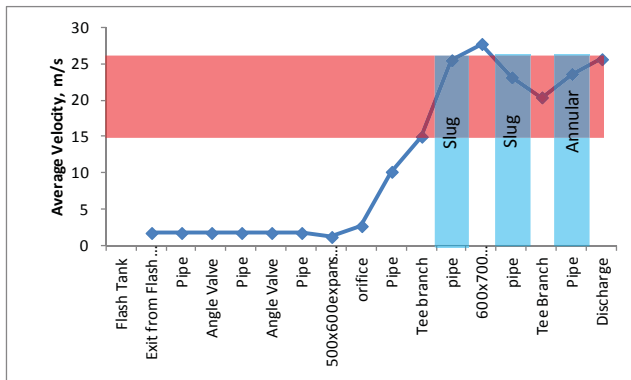

Figure 13: Average Velocity Profile Design C

Conclusions

This paper describes some of the different options concerning the design of flash tank pipe work, the implications of poor design and preventative measures that can be taken in order to identify regions of high wear. Mitigation strategies include changes in pipe work geometry, and positioning of expansions and sizing of restriction devices and strategic placement of wear resistant materials such as hard facing and brittle white iron inserts. The above method describes how the identification of regions of high wear can be achieved by using a one dimensional two phase flow model. This tool allows the prediction and optimization of pressure gradients so that high velocities in sensitive areas can be avoided. Although a powerful tool, it still does not capture three dimensional flows and the effect it can have on the rate of

localized wear on fittings with non symmetrical boundaries (i.e. a valve or a tee versus a pipe).

References

- Humphrey, J. A. C. "Fundamentals of fluid motion in erosion by solid particle impact ." *International Journal of Heat and Fluid Flow*, 1990: 170-195.
- Bitter, J. G. A. "A Study of Erosion Phenomena." *Wear*, 1963: 169-190.
- Barnea, D., Shoham, O., Taitel, Y., Duckler, A. E. Flow Pattern Transition For Gas-Liquid Flow In Horizontal and Inclined Pipes, Comparison of Experimental Data with Theory *International Journal of Multiphase Flow*, 1980: 217 - 225.
- Taitel, Y., Barnea, D., Dukler, A. E. "Modelling Flow Pattern Transitions for Steady Gas-Liquid Flows in Vertical Tubes." *AIChE*, 1980: 345-353.
- Friedel, L. "Improved friction pressure drop correlations for horizontal and vertical two-phase pipe flow." *European Two-Phase Flow Group Meeting*. Ispra , 1979.
- Lokhart, R.W., Martinelli, R.C. "Proposed Correlation of Data for Isothermal Two Phase Flow, Two Component Flow in Pipes." *Chemical Engineering Progress*, 1949: 39-48.
- Chisholm, D. "Pressure Gradients Due to Friction During the Flow of Evaporating Two-phase Mixtures in Smooth Tubes and Channels." *International Journal of Heat and Mass Transfer*, 1973: 347-358.
- Woldesemayat M., A., Ghajar, A., J. "Comparison of void fraction correlations for different flow patterns in horizontal and upward inclined pipes." *International Journal of Multiphase Flow*, 2007: 347-370.
- Vijayan, P. K., Patil, A. P., Pilkhwal, D. S., Venkat Raj, V. "An assessment of Pressure drop and Void Fraction Correlations with Data from Two-Phase Natural Circulation Loops." *Heat and Mass Transfer*, 2000: 541-548.
- D., Butterworth. A Comparison of some Void-Fraction Relationships for the Co-current Gas Liquid Flow. *International Journal of Multiphase Flow*, 1975: 845-850.
- Tran, Q., Reynolds, M., Sizing for Relief Valves for Two phase Flow in The Bayer Process, Alumina Quality Workshop, 1999
- Tran, Q., Tran, H., Momentum Change in Digestion Relief Headers, Alumina Quality Workshop, 2002