

تم تحميل هذا الملف من موقع المناهج الإماراتية



almanahj.com

موقع
المناهج الإماراتية

*للحصول على أوراق عمل لجميع الصفوف وجميع المواد اضغط هنا

<https://almanahj.com/ae>

* للحصول على أوراق عمل لجميع مواد الصف الثاني عشر المتقدم اضغط هنا [15/ae/com.almanahj//:https](https://almanahj.com/ae/15)

* للحصول على جميع أوراق الصف الثاني عشر المتقدم في مادة فيزياء ولجميع الفصول, اضغط هنا

<https://almanahj.com/ae/15physics>

* للحصول على أوراق عمل لجميع مواد الصف الثاني عشر المتقدم في مادة فيزياء الخاصة بـ الفصل الثاني اضغط هنا

<https://almanahj.com/ae/15physics2>

* لتحميل كتب جميع المواد في جميع الفصول للـ الصف الثاني عشر المتقدم اضغط هنا [grade15/ae/com.almanahj//:https](https://almanahj.com/ae/grade15)

للتحدث إلى بوت المناهج على تلغرام: اضغط هنا [bot_almanahj/me.t//:https](https://t.me/bot_almanahj)

Chapter 25: Current and Resistance

Concept Checks

25.1. e 25.2. a 25.3. a 25.4. a 25.5. a 25.6. e 25.7. c 25.8. b

Multiple-Choice Questions

25.1. d 25.2. d 25.3. c 25.4. c 25.5. c 25.6. a 25.7. c 25.8. a 25.9. c 25.10. a 25.11. c 25.12. d 25.13. d 25.14. a

Conceptual Questions

- 25.15. Subject to the applied potential and electric field E , the electrons will accelerate indefinitely due to the electric force $F = qE = ma$. The drift velocity and current will increase indefinitely until some other effect takes over.
- 25.16. The voltage across the light bulb is constant. The resistance of a piece of metal (the filament in the bulb) is lower at low temperatures compared to higher temperatures. Since $V = iR$ and V is constant, and the resistance is low, the current i must be large. When the light bulb is first turned on, the filament is cold, so the current is large. A large current increases the likelihood of the light bulb burning out.
- 25.17. They will be brighter if they are connected in parallel. In parallel, the light bulbs will pull twice the current from the battery, which is twice the power. In series, the circuit has twice the resistance, as it draws only half the current.
- 25.18. Resistors in parallel

$$R_{\text{parallel}} = \frac{1}{\frac{1}{R_1} + \frac{1}{R_2}} = \frac{R_1 R_2}{R_1 + R_2} = \frac{R_2}{1 + R_2 / R_1} < R_2 \text{ and } R_{\text{parallel}} = \frac{1}{\frac{1}{R_1} + \frac{1}{R_2}} = \frac{R_1 R_2}{R_1 + R_2} = \frac{R_1}{1 + R_1 / R_2} < R_1.$$

The resultant resistance is always smaller than the smaller of the two values. In particular, if the difference between the two values is large (an order of magnitude or more), the resultant resistance is less than but very close to the smaller of the two. Example: if you connect in parallel a resistor $R_1 = 1 \Omega$ and $R_2 = 10 \Omega$, you get a resistance of 0.91Ω . If $R_1 = 1 \text{ Ohm}$ and $R_2 = 1 \text{ k}\Omega$, you get a resistance of 0.999Ω .

- 25.19. In calculating power, we can use any of the following three equivalent formulas: $P = iV = Ri^2 = \frac{V^2}{R}$. For

resistors in series, the current is the same through all the resistors, so it makes sense to use $P = Ri^2$, and it is thus apparent that the higher the resistance, R of a resistor, the higher the power dissipated on that resistor. For resistors in parallel, the voltage across all the resistors is the same, so it makes sense to use

$P = \frac{V^2}{R}$, and it is thus apparent that the resistor with the lowest resistance will dissipate most power.

- 25.20. Consider the following diagram.

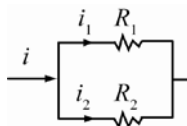

$$\frac{1}{R_{\text{eq}}} = \frac{1}{R_1} + \frac{1}{R_2} \Rightarrow R_{\text{eq}} = \frac{R_1 R_2}{R_1 + R_2}, \text{ so}$$

$$V_1 = V_2 = V = iR_{\text{eq}} \Rightarrow i_1 R_1 = i_2 R_2 = iR_{\text{eq}} \Rightarrow i_1 R_1 = i \frac{R_1 R_2}{R_1 + R_2} \Rightarrow i_1 = \frac{R_2}{R_1 + R_2} i.$$

25.21. Since the resistors are in parallel, $\frac{1}{R_T} = \frac{1}{R_1} + \frac{1}{R_2} + \frac{1}{R_3} + \dots = \frac{1}{R_T} = \frac{1}{R} + \frac{1}{R^2} + \frac{1}{R^3} + \dots$, and $R = 10 \Omega$. Let $x = \frac{1}{R} = \frac{1}{10 \Omega}$. The series can be rewritten as: $\frac{1}{R_T} = x + x^2 + x^3 + \dots \Rightarrow 1 + \frac{1}{R_T} = 1 + x + x^2 + x^3 + \dots$, but $1 + x + x^2 + x^3 + \dots = \frac{1}{(1-x)}$ for $|x| < 1$, and $\frac{1}{10} < 1$, so that means that $1 + \frac{1}{R_T} = \frac{1}{1-x} \Rightarrow \frac{1}{R_T} = \frac{1}{1-x} - 1 = \frac{1-1+x}{1-x} \Rightarrow \frac{1}{R_T} = \frac{x}{1-x} \Rightarrow R_T = \frac{1-x}{x} = \frac{1}{x} - 1$, which then gives the formula $\frac{1}{x} = R \Rightarrow R_T = R - 1 = 10 \Omega - 1 \Omega = 9 \Omega$.

25.22. The black wire, having lower resistance, will draw more power than the red wire since $P = iV = i^2R = \frac{\Delta V^2}{R}$, where ΔV is the battery voltage. Since the wire converts this electrical energy to thermal energy, the black wire will get hotter. Note that if the battery has significant internal resistance that will affect the temperature of the wires, but the black wire will still be hotter than the red wire.

25.23. No, ordinary incandescent light bulbs are not actually Ohm resistors. They can be operated over a wide enough range of currents, hence temperatures, that the temperature dependence of the filament resistance is significant. The resistance of an ordinary light bulb measured with an Ohmmeter at room temperature is substantially lower, that its resistance at an operating temperature of order 2000 K. By connecting light bulbs in series it is possible to operate them at a range of voltages, hence currents, wide enough to display this variation in resistance. The experiment is quite pretty as the light bulbs can be made to glow colors ranging from red through orange and yellow to white. A plot of V versus i for the light bulbs is not the straight line of an Ohm resistor it steepens noticeably the resistance increases as i increases.

25.24. (a) No assumptions can be made about the geometry and this is certainly not a steady state of equilibrium situation. However, if we consider a surface S surrounding the injection region as a Gaussian surface then the charge $Q(t)$ is given by Gauss' Law $Q(t) = \epsilon \oint_S \vec{E} \cdot d\vec{A}$, where the permittivity incorporates the dielectric properties of the material. The material is ohmic so the electric field E drives current density $J = \sigma E$. Hence, the above equation can be written $Q(t) = (\epsilon / \sigma) \oint_S \vec{J} \cdot d\vec{A}$. By the definition of J , the integral here is the net rate of charge transport out of the volume surrounded by S . Charge conservation requires that this be equal to the rate of decrease of the charge within that volume (no charge can be gained or lost): $\oint_S \vec{J} \cdot d\vec{A} = -dQ/dt$. This is the *certainty equation* for electric charge: it is similar to the continuity equation of field mechanics, which expresses the conservation of field mass for particle number. It has the advantage that it applies in every situation. Here it implies $\frac{dQ}{dt} = -(\sigma/\epsilon)Q$ is the desired differential equation.

(b) Students at this level should recognize immediately that the solution of a differential equation of this form is an exponential function. Explicitly, the equation implies

$$\int_{Q_0}^{Q(t)} \frac{dQ'}{Q'} = -\frac{\sigma}{\epsilon} \int_0^t dt', \text{ or } \ln\left(\frac{Q(t)}{Q_0}\right) = -\frac{\sigma t}{\epsilon}, \text{ i.e. } Q(t) = Q_0 \exp\left(-\frac{\sigma t}{\epsilon}\right),$$

for all $t \geq 0$. The charge in the injection region decays exponentially rapidly for a good conductor slowly for a poor one and the injected charge moves to the outer surface of the conductor.

(c) The preceding result implies that the time required for the charge in the injection region to decrease by half is $t_{1/2} = \epsilon \ln\left(\frac{2}{\sigma}\right)$. For copper, $\sigma = (1.678 \cdot 10^{-8} \Omega \text{ m})^{-1}$ at 20 °C and $\epsilon = \epsilon_0$ by assumption yielding

$$t_{1/2}^{\text{Cu}} = \frac{(8.85 \cdot 10^{-12} \text{ C}^2 / \text{N m}^2) \ln 2}{5.959 \cdot 10^7 (\Omega \text{ m})^{-1}} = 1.03 \cdot 10^{-19} \text{ s.}$$

This is less than the crossing time of light over a single atom so this calculation particularly the assumptions of Ohmic behavior and unit “dielectric constant” may not be very accurate in this case. It does indicate; however, that the evacuation of free charge from the interior of a good conductor is very rapid. For quartz the data is somewhat varied. *The Handbook of Chemistry and Physics* gives $\sigma = (1 \cdot 10^3 \Omega \text{ m})^{-1}$ at 20 °C for SiO₂ and $\epsilon = (3.75 - 4.1)\epsilon_0$ for fused quartz. A typical value for $t_{1/2}$ would be

$$t_{1/2}^{\text{SiO}_2} = \frac{3.9(8.85 \cdot 10^{-12} \text{ C}^2 / (\text{N m}^2)) \ln 2}{1 \cdot 10^{-13} (\Omega \text{ m})^{-1}} = 200 \text{ s}$$

over three minutes, some twenty one orders of magnitude longer. *Reitz and Milford* gives $\sigma = (7.5 \cdot 10^{17} \Omega \text{ m})^{-1}$ for fused quartz.

This implies a value $t_{1/2}^{\text{SiO}_2} = \frac{3.9(8.854 \cdot 10^{-12} \text{ C}^2 / (\text{N m}^2)) \ln 2}{1.3 \cdot 10^{-18} (\Omega \text{ m})^{-1}} = 1.8 \cdot 10^7 \text{ s}$, or about 210 days.

- 25.25. You can write the drift speed of electrons in a wire as $v = \frac{i}{(nqA)}$. For a wire connected across a potential difference V , you can find the current i in the wire by determining the resistance of the gold wire, which is just $R = \rho_{\text{resistivity, Au}} \Delta x / A$, where Δx is its length. Therefore,

$$v = \frac{i}{nqA} = \frac{V}{nqAR} = \frac{V}{nqA \rho_{\text{resistivity, Au}} (\Delta x / A)} = \frac{V}{nq \rho_{\text{resistivity, Au}} \Delta x}.$$

Thus, since none of the quantities in the equation above depend on A , it has been shown that the speed of electrons does not depend on the cross-sectional area of the wire.

- 25.26. The brightness of a light bulb is proportional to its current, so to rank the brightness of the bulbs, you will need to find and rank the currents. The currents can be found by calculating the equivalent resistance for the different circuit elements. Bulbs 1 and 2 are in series, so $i_1 = i_2$. The equivalent resistance for the 2 bulbs is $2R$. The current through bulbs 1 and 2 is $i_1 = i_2 = V / (2R)$. Bulbs 5 and 6 are in series, so $i_5 = i_6$. The equivalent resistance for the 2 bulbs is $2R$. The equivalent resistance for bulbs 4, 5, and 6 is $R_{456} = [1/R + 1/(2R)]^{-1} = (2/3)R$. Adding bulb 3 in series gives: $R_{3456} = (5/3)R$ and the current in bulb 3 is: $i_3 = 3V / (5R)$. The voltage across bulbs 4, 5 and 6 is then $V - (3/5)V = (2/5)V$. This makes the currents in bulbs 4, 5 and 6: $i_4 = 2V / (5R)$ and $i_5 = i_6 = V / (5R)$. Ranking the bulbs from dimmest to brightest: $(i_5 = i_6) < i_4 < (i_1 = i_2) < i_3$.
- 25.27. Conductor 1: length = L , Radius = R , Area = A , Resistance = R and Voltage = V . Conductor 2: length = L , Radius = R , Area = A , Resistance = $2R$ and Voltage = V . Power delivered is given as $P = \frac{V^2}{R}$, $P_1 = \frac{V^2}{R}$, $P_2 = \frac{V^2}{2R} = \frac{P_1}{2}$. Therefore, the power delivered to the first would be twice that delivered to the second.

Exercises

- 25.28. The total charge in the Tevatron is $Q = i\Delta t$. Now, $\Delta t = L/v$, where L is the beam circumference and v is the speed of the protons. $i = 11 \cdot 10^{-3}$ A, $L = 6.3 \cdot 10^3$ m and $v = c = 3.00 \cdot 10^8$ m/s. This charge is made up of n protons:

$$Q = ne = i\Delta t = \frac{iL}{v} \Rightarrow n = \frac{iL}{e \cdot c} = \frac{(1.10 \cdot 10^{-2} \text{ A})(6.30 \cdot 10^3 \text{ m})}{(1.602 \cdot 10^{-19} \text{ C})(3.00 \cdot 10^8 \text{ m/s})} = 1.4 \cdot 10^{12}.$$

- 25.29. The area A is $A = \pi r^2 = 3.14 \cdot 10^{-6}$ m², so the current density is

$$J = \frac{i}{A} = \frac{1.00 \cdot 10^{-3} \text{ A}}{3.14 \cdot 10^{-6} \text{ m}^2} = 318.3 \text{ A/m}^2 \approx 318 \text{ A/m}^2.$$

The density of electrons is

$$n = \left(\frac{1 \text{ electron}}{\text{atom}} \right) \left(\frac{6.02 \cdot 10^{23} \text{ atoms}}{26.98 \text{ g}} \right) \left(\frac{2.700 \cdot 10^6 \text{ g}}{\text{m}^3} \right) = 6.02 \cdot 10^{28} \text{ electrons/m}^3,$$

and the drift speed is

$$v_d = \frac{J}{ne} = \frac{318.3 \text{ A/m}^2}{(6.02 \cdot 10^{28} \text{ electrons/m}^3)(1.602 \cdot 10^{-19} \text{ A s})} = 3.30 \cdot 10^{-8} \text{ m/s}.$$

- 25.30. **THINK:** The current is the same in both wires due to conservation of charge. This can be used to compute the ratio of current densities. The ratio of the drift velocities can then be computed by expressing the drift velocities in terms of the current density. The densities of charge carriers are charges per electron: $n_{\text{Cu}} = 8.50 \cdot 10^{28} \text{ m}^{-3}$ and $n_{\text{Al}} = 6.02 \cdot 10^{28} \text{ m}^{-3}$. The other values given in the question that will be needed are $d_{\text{Cu}} = 5.00 \cdot 10^{-4}$ m, and $d_{\text{Al}} = 1.00 \cdot 10^{-4}$ m. The lengths of the wires and the amount of current are not necessary to solve the question.

SKETCH:

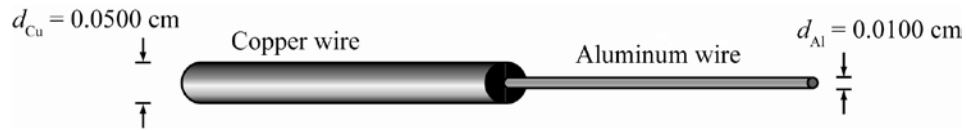

RESEARCH: $J = i/A$, $A = \text{cross-sectional area}$, $J = nev_d$ and $A = \pi r^2$.

SIMPLIFY:

$$(a) \frac{J_{\text{Cu}}}{J_{\text{Al}}} = \frac{i/A_{\text{Cu}}}{i/A_{\text{Al}}} = \frac{A_{\text{Al}}}{A_{\text{Cu}}} = \frac{\pi(d_{\text{Al}}/2)^2}{\pi(d_{\text{Cu}}/2)^2} = \frac{d_{\text{Al}}^2}{d_{\text{Cu}}^2}$$

$$(b) v_d = \frac{J}{ne} \Rightarrow \frac{v_{d,\text{Cu}}}{v_{d,\text{Al}}} = \frac{J_{\text{Cu}}/(n_{\text{Cu}}e)}{J_{\text{Al}}/(n_{\text{Al}}e)} = \left(\frac{J_{\text{Cu}}}{J_{\text{Al}}} \right) \left(\frac{n_{\text{Al}}}{n_{\text{Cu}}} \right)$$

CALCULATE:

$$(a) \frac{J_{\text{Cu}}}{J_{\text{Al}}} = \frac{(1.00 \cdot 10^{-4} \text{ m})^2}{(5.00 \cdot 10^{-4} \text{ m})^2} = 0.040000$$

$$(b) \frac{v_{d,\text{Cu}}}{v_{d,\text{Al}}} = \left(\frac{J_{\text{Cu}}}{J_{\text{Al}}} \right) \left(\frac{n_{\text{Al}}}{n_{\text{Cu}}} \right) = (0.0400) \left(\frac{6.02 \cdot 10^{28} \text{ m}^{-3}}{8.50 \cdot 10^{28} \text{ m}^{-3}} \right) = 0.02833$$

ROUND:

(a) $\frac{J_{\text{Cu}}}{J_{\text{Al}}} = 0.0400$

(b) $\frac{v_{\text{d-Cu}}}{v_{\text{d-Al}}} = 0.0283$

DOUBLE-CHECK: The answers are dimensionless since they are ratios.

- 25.31. THINK:** From the atomic weight and density of silver, the conduction electron density can be computed. Since both the current and the cross-sectional area of the wire are given, the current density can be computed and, using the calculated quantities, the drift speed of the electrons can be computed. Use the data: $A = 0.923 \text{ mm}^2$, $i = 0.123 \text{ mA}$, $M = 107.9 \text{ g/mol}$, $\rho_{\text{Ag}} = 10.49 \text{ g/cm}^3$, $N_{\text{A}} = 6.02 \cdot 10^{23} \text{ mol}^{-1}$, $N = 1 \text{ electron/atom}$ and $e = 1.602 \cdot 10^{-19} \text{ C}$.

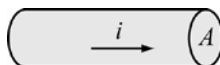
SKETCH:**RESEARCH:**

(a) $n = \frac{N \rho_{\text{Ag}} N_{\text{A}}}{M}$

(b) $J = \frac{i}{A}$

(c) $J = nev_{\text{d}}$

SIMPLIFY:

(a) Not required.

(b) Not required.

(c) $v_{\text{d}} = J / ne$

CALCULATE:

(a) $n = \frac{1(10.49 \text{ g/cm}^3)(6.02 \cdot 10^{23} \text{ mol}^{-1})}{107.9 \text{ g/mol}} = 5.853 \cdot 10^{22} \text{ cm}^{-3}$

(b) $J = \frac{0.123 \cdot 10^{-3} \text{ A}}{(0.923 \text{ mm}^2)(10^{-3} \text{ m/mm})^2} = 133.3 \text{ A/m}^2$

(c) $v_{\text{d}} = \frac{133.3 \text{ A/m}^2}{(5.853 \cdot 10^{22} \text{ cm}^{-3})(10^2 \text{ cm/m})^3(1.602 \cdot 10^{-19} \text{ C})} = 1.421 \cdot 10^{-8} \text{ m/s}$

ROUND: Three significant figures:

(a) $n = 5.85 \cdot 10^{22} \text{ cm}^{-3}$

(b) $J = 133 \text{ A/m}^2$

(c) $v_{\text{d}} = 1.42 \cdot 10^{-8} \text{ m/s}$

DOUBLE-CHECK: These are reasonable values. Note that for part (a), only the composition and not the dimensions of the wire are relevant.

25.32. $R = \rho_{\text{Cu}} \frac{L}{A} = (1.72 \cdot 10^{-8} \Omega \text{m}) \frac{10.9 \text{ m}}{\pi(1.3 \cdot 10^{-3} \text{ m}/2)^2} = 0.141 \Omega$

25.33. The resistances will be the same when their cross-sectional areas are the same.

$$\pi R_B^2 = \pi \left(\frac{d_o}{2} \right)^2 - \pi \left(\frac{d_i}{2} \right)^2 \Rightarrow R_B = \frac{1}{2} \sqrt{d_o^2 - d_i^2}$$

$$\Rightarrow R_B = \frac{1}{2} \sqrt{(3.00 \text{ mm})^2 - (2.00 \text{ mm})^2} = 1.12 \text{ mm}$$

25.34. The copper coil's resistance increases linearly with temperature. At $T_0 = 20.^\circ\text{C} = 293.15 \text{ K}$, it has resistance $R_0 = 0.10 \Omega$. The temperature coefficient of copper is $\alpha = 3.9 \cdot 10^{-3} \text{ K}^{-1}$. At $T = -100.^\circ\text{C} = 173.15 \text{ K}$,

$$R = R_0(1 + \alpha(T - T_0)) = (0.10 \Omega) \left(1 + (3.9 \cdot 10^{-3} \text{ K}^{-1})(173.15 \text{ K} - 293.15 \text{ K}) \right) = 0.053 \Omega.$$

25.35. The area of 12 gauge copper wire is $A_{\text{Cu}} = 3.308 \text{ mm}^2$. The resistivity of copper and aluminum are, $\rho_{\text{Cu}} = 1.72 \cdot 10^{-8} \Omega \text{ m}$ and $\rho_{\text{Al}} = 2.82 \cdot 10^{-8} \Omega \text{ m}$. In general the equation for resistance is $R = \rho L / A$, meaning if the two wires have equal resistance per length (L), then

$$\frac{\rho_{\text{Cu}}}{A_{\text{Cu}}} = \frac{\rho_{\text{Al}}}{A_{\text{Al}}} \Rightarrow A_{\text{Al}} = \frac{\rho_{\text{Al}} A_{\text{Cu}}}{\rho_{\text{Cu}}} = \frac{(2.82 \cdot 10^{-8} \Omega \text{ m})(3.308 \text{ mm}^2)}{1.72 \cdot 10^{-8} \Omega \text{ m}} = 5.42 \text{ mm}^2.$$

This value corresponds to between 9 and 10 gauge wire.

25.36. Since the resistance is given as $R = \rho L / A$, then the setup that maximizes L and minimizes A will give the largest resistance. This corresponds to choosing $L = 3.00 \text{ cm}$ and $A = (2.00 \text{ cm})(0.010 \text{ cm}) = 0.020 \text{ cm}^2$. The resistivity is $\rho = 2300 \Omega \text{ m}$. Therefore, the maximum resistance is

$$R_{\text{max}} = \frac{\rho L}{A} = \frac{(2300 \Omega \text{ m})(3.00 \text{ cm})}{(0.020 \text{ cm}^2)} \cdot \left(\frac{100 \text{ cm}}{1 \text{ m}} \right) = 3.5 \cdot 10^7 \Omega = 35 \text{ M}\Omega.$$

25.37. **THINK:** The copper wire, $L_1 = 1 \text{ m}$ and $r_1 = 0.5 \text{ mm}$, has an area of A_1 . The wire is then stretched to $L_2 = 2 \text{ m}$. Since the overall volume ($V = AL$) of the wire remains constant, if the wire doubles in length, the area must be halved.

SKETCH:

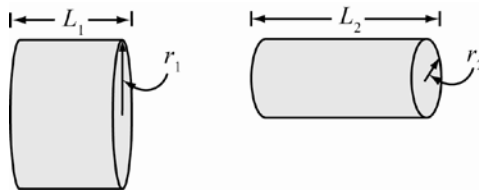

RESEARCH: The resistance of the wire is $R_i = \rho L_i / A_i$. From the conservation of volume, it follows that $V = A_1 L_1 = A_2 L_2$. The fractional change in resistance is $\Delta R / R = (R_2 - R_1) / R_1$.

SIMPLIFY: Since $L_2 = 2L_1$, then $A_2 = (1/2)A_1$. The change in resistance is then $\frac{\Delta R}{R} = \frac{(R_2 - R_1)}{R_1} = \frac{\rho(L_2 / A_2 - L_1 / A_1)}{\rho(L_1 / A_1)} = \frac{2L_1 / ((1/2)A_1) - L_1 / A_1}{L_1 / A_1} = \frac{4L_1 / A_1 - L_1 / A_1}{L_1 / A_1} = 3$. It is the same for aluminum, independent of ρ .

CALCULATE: Not required.

ROUND: Not required.

DOUBLE-CHECK: It would seem to make sense that the fractional change in resistance is the same for all materials, so having the equation independent of ρ makes sense.

- 25.38. THINK:** The actual cross-sectional area of the resistor, $L = 60$ cm and $R_0 = 1$ Ohm, is the difference in area from outer radius, $b = 2.5$ cm, and inner radius, $a = 1.5$ cm. The resistance of the resistor should vary linearly with temperature from $T = 300$ °C to $T_0 = 20$ °C with $\alpha = 2.14 \cdot 10^{-3}$ K⁻¹.

SKETCH:

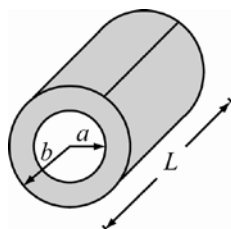

RESEARCH: The resistivity of the wire is given by $\rho = RA/L$, where the area of interest is $A = \pi(b^2 - a^2)$. The resistance varies with the temperature: $R = R_0(1 + \alpha(T - T_0))$. The percentage change of resistance is found by $(\Delta R/R)(100\%)$.

SIMPLIFY:

(a) The resistivity is $\rho = \frac{RA}{L} = \frac{R_0\pi(b^2 - a^2)}{L}$.

(b) The fractional change in resistance is:

$$\% \frac{\Delta R}{R} = \frac{(R - R_0)}{R_0}(100\%) = \frac{R_0(1 + \alpha(T - T_0)) - R_0}{R_0}(100\%) = \alpha(T - T_0)(100\%).$$

CALCULATE:

(a) $\rho = \frac{(1.00 \Omega)\pi((2.50 \text{ cm})^2 - (1.50 \text{ cm})^2)}{60.0 \text{ cm}} = 0.20944 \Omega \text{ cm}$

(b) $\% \frac{\Delta R}{R} = (2.14 \cdot 10^{-3} \text{ K}^{-1})(300. \text{ °C} - 20. \text{ °C})(100\%) = 59.92\%$

ROUND:

(a) $\rho = 0.209 \Omega \text{ cm}$, which is much higher than $\rho = 1.7 \cdot 10^{-6} \Omega \text{ cm}$ for copper.

(b) $\% \frac{\Delta R}{R} = 59.9\%$

DOUBLE-CHECK: It makes sense that a resistor would be made of material that has a much higher resistivity than the wiring it connects to but a much lower resistivity than insulating materials that block current altogether (such as glass, $\rho > 10^7 \Omega \text{ cm}$).

- 25.39. THINK:** Since the current density across the junction is constant, J , and they share the same cross-sectional area, they have the same current, i . At the junction, a positive charge will build up, and this means both electric fields, E_1 and E_2 , are pointing towards the junction. Gauss's Law can then be used to determine the total charge built up on the interface. The electric fields are also related to the conductivities, σ_1 and σ_2 .

SKETCH:

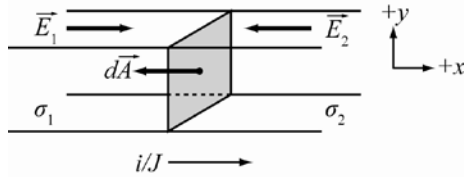

RESEARCH: The conductivity is the inverse of resistivity, $\sigma = 1/\rho$. The resistivity is related to electric field by $\rho = E/J$. At the junction, Gauss's law states $\oiint \vec{E} \cdot d\vec{A} = q/\epsilon_0$. The current density J , is $J = i/A$.

SIMPLIFY: From the conductivity and resistivity, the current density is $\sigma = 1/\rho = 1/(E/J) = J/E \Rightarrow J = \sigma E$; therefore, $\sigma_1 E_1 = \sigma_2 E_2$ or $E_1 = (\sigma_2/\sigma_1)E_2$. Since \vec{E}_2 is parallel and \vec{E}_1 is antiparallel to $d\vec{A}$, $\oiint \vec{E} \cdot d\vec{A} = (E_2 - E_1)A = q/\epsilon_0$. Solving this expression for q yields the following.

$$q = \epsilon_0 (E_2 - E_1)A = \epsilon_0 \left(E_2 - \left(\frac{\sigma_2}{\sigma_1} E_2 \right) \right) A = \epsilon_0 E_2 \left(1 - \left(\frac{\sigma_2}{\sigma_1} \right) \right) \left(\frac{i}{J} \right) = \epsilon_0 E_2 \left(1 - \frac{\sigma_2}{\sigma_1} \right) \left(\frac{i}{\sigma_2 E_2} \right) = \epsilon_0 i \left(\frac{1}{\sigma_2} - \frac{1}{\sigma_1} \right)$$

This is what was required to be shown.

CALCULATE: Not required.

ROUND: Not required.

DOUBLE-CHECK: The equation was verified, so it makes sense.

25.40. (a)

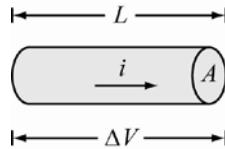

Since the potential across wire is $\Delta V = 12.0 \text{ V}$ and the current is $i = 3.20 \cdot 10^{-3} \text{ A}$. Ohm's Law states $\Delta V = iR \Rightarrow R = \frac{\Delta V}{i} = \frac{12.0 \text{ V}}{3.20 \cdot 10^{-3} \text{ A}} = 3750 \Omega$.

(b) Since the wire is $L = 1000. \text{ km}$ long and has area of $A = 4.50 \text{ mm}^2$, the resistivity of it is $R = \rho \frac{L}{A} \Rightarrow \rho = \frac{RA}{L} = \frac{(3750 \Omega)(4.50 \cdot 10^{-6} \text{ m}^2)}{(1000 \cdot 10^3 \text{ m})} = 1.69 \cdot 10^{-8} \Omega \text{ m}$, therefore, the wire is most likely copper ($\rho_C = 1.72 \cdot 10^{-8} \Omega \text{ m}$).

25.41. The current is $i = 600. \text{ A}$ and the potential difference is $\Delta V = 12.0 \text{ V}$. Therefore, Ohm's Law states $\Delta V = iR \Rightarrow R = \Delta V / i = 12.0 \text{ V} / (600. \text{ A}) = 0.0200 \Omega$.

25.42. **THINK:** The resistance of the wire of radius $r = 0.0250 \text{ cm}$ and length $L = 3.00 \text{ m}$ is found by using its resistivity $\rho = 1.72 \cdot 10^{-8} \Omega \text{ m}$. The potential drop is found using the current, $i = 0.400 \text{ A}$, and Ohm's Law. Assuming the electric field is constant, it is simply found through the potential drop over the length.

SKETCH:

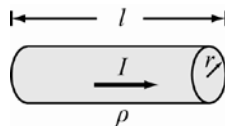

RESEARCH: The resistance is $R = \rho L / A$. The area of the wire is $A = \pi r^2$. The potential difference across the wire is $\Delta V = iR$. The electric field across the wire is $E = \Delta V / L$.

SIMPLIFY:

(a) The resistance is $R = \frac{\rho L}{A} = \frac{\rho L}{\pi r^2}$.

(b) The potential difference across the wire is $\Delta V = iR$.

(c) The electric field across the wire is $E = \frac{\Delta V}{L}$.

CALCULATE:

(a) $R = \frac{(1.72 \cdot 10^{-8} \Omega \text{ m})(3.00 \text{ m})}{\pi(0.0250 \text{ cm})^2} = 0.2628 \Omega$

(b) $\Delta V = (0.400 \text{ A})(0.2628 \Omega) = 0.10512 \text{ V}$

(c) $E = \frac{0.10512 \text{ V}}{3.00 \text{ m}} = 0.03504 \text{ V/m} = 0.0350 \text{ V/m}$

ROUND: Rounding to three significant figures;

(a) $R = 0.263 \Omega$

(b) $\Delta V = 0.105 \text{ V}$

(c) $E = 0.0350 \text{ V/m}$

DOUBLE-CHECK: The wire loses very little potential over a long length. This means that this wire used in a standard circuit which would only be a few centimeters in length would only lose about 1 or 2 mV, making it a suitable material for a circuit.

- 25.43. THINK:** The length and resistivity of the wire are $L = 1.0 \text{ m}$ and $\rho = 1.72 \cdot 10^{-8} \Omega \text{ m}$. The area of the wire is $A = 0.0201 \text{ mm}^2$. Since the resistance changes linearly with the temperature, $T_0 = 20.^\circ \text{C}$ and $T = -196^\circ \text{C}$, the percentage change in resistance is proportional, by $\alpha = 3.9 \cdot 10^{-3} \text{ K}^{-1}$, to the temperature difference. Since the current is directly related to the resistance, the percentage change in resistance is related to the resistances themselves. Using the molar mass and density of copper, $m = 0.06354 \text{ kg}$ and $\rho_{\text{Cu}} = 8.92 \cdot 10^3 \text{ kg/m}^3$, the carrier density, n , can be determined, which in turn allows velocity to be found. Use the value $\Delta V = 0.1 \text{ V}$.

SKETCH:

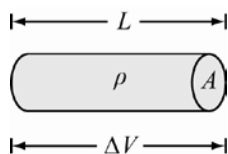

RESEARCH: The resistance of the wire is $R = \rho L / A$. From Ohm's Law, the potential drop across the wire is $\Delta V = IR$. The resistance changes linearly with temperature by $R = R_0(1 + \alpha(T - T_0))$. For a given quantity, x , the percentage change in it is therefore, $\Delta x / x = ((x - x_0) / x_0)(100\%)$. Current density is $J = nev_2 = i / A$.

SIMPLIFY:

(a) The original resistance is $R_0 = \rho L / A$. The cooled resistance is $R = R_0(1 + \alpha(T - T_0))$; therefore,

$$\% \frac{\Delta R}{R} = \frac{R - R_0}{R_0} = \frac{R_0(1 + \alpha(T - T_0)) - R_0}{R_0} = -\alpha(T - T_0)(100\%).$$

(b) The percentage change in current is found using the following equations.

$$\begin{aligned}\frac{\Delta i}{i} &= \frac{i - i_0}{i_0} = \frac{\Delta V / R - \Delta V / R_0}{\Delta V / R_0} = \frac{1/R - 1/R_0}{1/R_0} = \frac{R_0 - R}{RR_0} R_0 = \frac{R_0 - R}{R} = \frac{R_0 - R_0(1 + \alpha(T - T_0))}{R_0(1 + \alpha(T - T_0))} \\ &= \frac{-\alpha(T - T_0)}{(1 + \alpha(T - T_0))} (100\%)\end{aligned}$$

(c) Assume each copper atom contributes just $1 e^-$. The molar volume of copper is $V_{\text{Cu}} = \rho_{\text{Cu}} / m$; therefore, $n = N_A \rho_{\text{Cu}} / m$. The drift velocity is then, in general,

$$\begin{aligned}J &= \frac{i}{A} = nev_d \\ \Rightarrow v_d &= \frac{i}{neA} = \frac{\Delta V}{neAR} = \frac{\Delta V}{neAR_0(1 + \alpha(T - T_0))} \\ \Rightarrow v_d &= \frac{\Delta V}{neA(\rho L / A)(1 + \alpha(T - T_0))} = \frac{\Delta V}{ne\rho L(1 + \alpha(T - T_0))}.\end{aligned}$$

At $T = T_0$ and $V_d = \Delta V / ne\rho L$.

CALCULATE:

$$(a) \% \Delta R / R = -(3.9 \cdot 10^{-3} \text{ K}^{-1})(-196 \text{ }^\circ\text{C} - 20. \text{ }^\circ\text{C})(100\%) = -84.24\%$$

$$(b) \% \Delta i / i = \frac{-(3.9 \cdot 10^{-3} \text{ K}^{-1})(-196 \text{ }^\circ\text{C} - 20. \text{ }^\circ\text{C})}{1 + (3.9 \cdot 10^{-3} \text{ K}^{-1})(-196 \text{ }^\circ\text{C} - 20. \text{ }^\circ\text{C})} (100\%) = 534.5\%$$

$$(c) n = \frac{(6.022 \cdot 10^{23} e^-)(8.92 \cdot 10^3 \text{ kg/m}^3)}{0.06354 \text{ kg}} = 8.4539 \cdot 10^{28} e^- / \text{m}^3$$

$$\text{At room temperature, } V_d = \frac{0.10 \text{ V}}{(8.4535 \cdot 10^{28} e^- / \text{m}^3)(1.602 \cdot 10^{-19} \text{ C})(1.72 \cdot 10^{-8} \text{ } \Omega\text{m})(1.0 \text{ m})} = 0.4293 \text{ mm/s.}$$

$$\text{At temperature, } T = -196 \text{ }^\circ\text{C, } V_d = \frac{0.4293 \text{ mm/s}}{1 + (3.9 \cdot 10^{-3} \text{ K}^{-1})(-196 \text{ }^\circ\text{C} - 20. \text{ }^\circ\text{C})} = 2.724 \text{ mm/s.}$$

ROUND:

(a) $\% \Delta R / R = -84\%$ (decrease in resistance)

(b) $\% \Delta I / I = 530\%$ (increase in current)

(c) At room temperature, $V_d = 0.43 \text{ mm/s}$. At 77 K the speed is $V_d = 2.7 \text{ mm/s}$.

DOUBLE-CHECK: Supercooling a resistor should greatly reduce the resistance and increase the current and drift velocity, which it does, so it makes sense.

25.44. If the current, $i = 11 \text{ A}$, went entirely through the known resistor, $R_0 = 35 \text{ } \Omega$, the potential drop across it would be $\Delta V = iR_0 = (11 \text{ A})(35 \text{ } \Omega) = 385 \text{ V}$, which is too large, so the other resistor must be parallel to R_0 .

$$\text{Therefore, by Ohm's Law, } \Delta V = i \left(\frac{1}{R} + \frac{1}{R_0} \right)^{-1} \Rightarrow R = \left(\frac{i}{\Delta V} - \frac{1}{R_0} \right)^{-1} = \left(\frac{11 \text{ A}}{120 \text{ V}} - \frac{1}{35 \text{ } \Omega} \right)^{-1} = 15.849 \text{ } \Omega.$$

Hence, $\Delta V = 15.8 \text{ } \Omega$.

25.45. When the external resistor, $R = 17.91 \text{ } \Omega$ is connected, the potential drop across it is $\Delta V = 12.68 \text{ V}$, so the current through the circuit is, by Ohm's Law, $i = \Delta V / R = 12.68 \text{ V} / 17.91 \text{ } \Omega = 0.70798 \text{ A} = 0.7080 \text{ A}$. This is the same current running through the internal resistor, R_i , which is in series with R , so since the battery has a total emf of $\Delta V_{\text{emf}} = 14.50 \text{ V}$, the internal resistance is found using the following calculation. $\Delta V_{\text{emf}} = i(R + R_i) \Rightarrow R_i = \frac{\Delta V_{\text{emf}}}{i} - R = \frac{14.50 \text{ V}}{0.7080 \text{ A}} - 17.91 \text{ } \Omega = 2.5702 \text{ } \Omega = 2.570 \text{ } \Omega$

- 25.46. The two resistors, $R_1 = 100. \Omega$ and $R_2 = 400. \Omega$, cause currents, $i_1 = 4.00 \text{ A}$ and $i_2 = 1.01 \text{ A}$, respectively. The currents they cause are the same through the internal resistor, R_i , and in both cases the emf of the battery, ΔV , is the same. Since R_i is in series with each of the other resistors, Ohm's Law says:

$$\begin{aligned} \Delta V = i_1(R_1 + R_i) = i_2(R_2 + R_i) &\Rightarrow i_2 R_2 - i_1 R_1 = R_i(i_1 - i_2) \Rightarrow R_i = \frac{i_2 R_2 - i_1 R_1}{i_1 - i_2} \\ &\Rightarrow R_i = \frac{(1.01 \text{ A})(400. \Omega) - (4.00 \text{ A})(100. \Omega)}{(4.00 \text{ A} - 1.01 \text{ A})} = 1.3378 \Omega \approx 1.34 \Omega. \end{aligned}$$

- 25.47. **THINK:** The resistance in each bulb is directly calculated by Ohm's Law. Consider temperature effects on resistance to explain discrepancy with parts (a) and (b). Use the values: $\Delta V_1 = 6.20 \text{ V}$, $i_1 = 4.1 \text{ A}$, $i_2 = 2.9 \text{ A}$ and $\Delta V_2 = 6.29 \text{ V}$.

SKETCH:

(a)

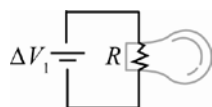

(b)

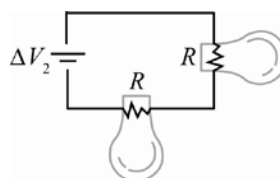

RESEARCH: By Ohm's Law, $\Delta V_1 = i_1 R$ for one light bulb and $\Delta V_2 = i_2 (R + R)$ for both light bulbs.

SIMPLIFY:

$$(a) \Delta V_1 = i_1 R \Rightarrow R = \frac{\Delta V_1}{i_1}$$

$$(b) \Delta V_2 = i_2 (R + R) \Rightarrow R = \frac{\Delta V_2}{2i_2}$$

CALCULATE:

$$(a) R = \frac{6.20 \text{ V}}{4.1 \text{ A}} = 1.5122 \Omega$$

$$(b) R = \frac{6.29 \text{ V}}{2(2.9 \text{ A})} = 1.084 \Omega$$

ROUND:

$$(a) R = 1.51 \Omega$$

$$(b) R = 1.08 \Omega.$$

(c) When two bulbs are put in series, it is expected that they glow dimmer than only one bulb. This would mean the one bulb would be hotter and thus have a larger resistance.

DOUBLE-CHECK: Answer to part (c) helps to verify that the answers to parts (a) and (b) are reasonable.

- 25.48. Simplifying the circuit gives

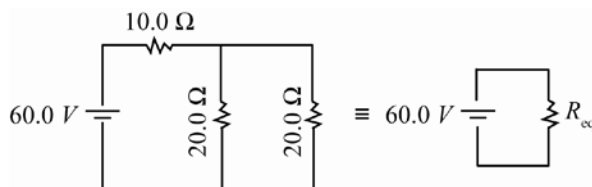

$R_{\text{eq}} = 10.0 \Omega + [1/(20.0 \Omega) + 1/(20.0 \Omega)]^{-1} = 20.0 \Omega$. By Ohm's Law, the current through R_{eq} is $i_{\text{eq}} = 60.0 \text{ V}/(20.0 \Omega) = 3.00 \text{ A}$. From the circuit setup, the current through R_{eq} is the same as that through the 10.0Ω resistor, which is 3.00 A .

- 25.49. **THINK:** The circuit can be redrawn to have the $10.0\ \Omega$ and $20.0\ \Omega$ resistors in series, both of which are parallel to the $30.0\ \Omega$ resistor, and then parallel again with the $40.0\ \Omega$ resistor. These resistors are then put in series with the $50.0\ \Omega$ resistor and the $60.0\ \text{V}$ battery.

SKETCH:

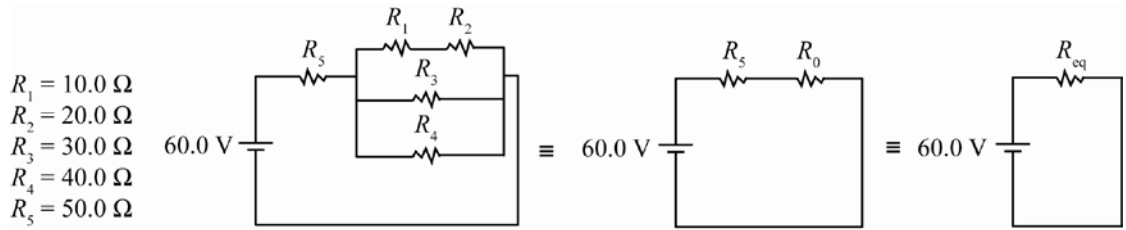

RESEARCH: Resistors in series combine as $R_{\text{eq}} = \sum_{i=1}^n R_i$. Resistors in parallel combine as $\frac{1}{R_{\text{eq}}} = \sum_{i=1}^n \frac{1}{R_i}$.

SIMPLIFY: The combined resistors in parallel become R_p where

$$R_p^{-1} = (R_1 + R_2)^{-1} + R_3^{-1} + R_4^{-1} \Rightarrow R_p = \left(\frac{1}{R_1 + R_2} + \frac{1}{R_3} + \frac{1}{R_4} \right)^{-1}$$

The equivalent resistance is $R_{\text{eq}} = R_5 + R_p$.

CALCULATE: $R_p = \left(\frac{1}{10.0\ \Omega + 20.0\ \Omega} + \frac{1}{30.0\ \Omega} + \frac{1}{40.0\ \Omega} \right)^{-1} = 10.909091\ \Omega$

$$R_{\text{eq}} = 50.0\ \Omega + 10.909091\ \Omega = 60.909091\ \Omega$$

ROUND: The result should be rounded to three significant figures: $R_{\text{eq}} = 60.9\ \Omega$.

DOUBLE-CHECK: If you add N equal resistors, R , in parallel, the equivalent resistance is R/N . Since the resistors in parallel are all about $30\ \Omega$ in each branch, the equivalent resistance should be about $10\ \Omega$, which is close to the calculated answer of $11\ \Omega$. Therefore, the values of R_p and R_{eq} are reasonable.

- 25.50. **THINK:** When the switch is open, the current clearly breaks up into paths and the two left resistors, $R_1 = R_3 = 3.00\ \Omega$, are in parallel with the two resistors, $R_2 = 5.00\ \Omega$ and $R_4 = 1.00\ \Omega$. When the switch is closed, it is not as obvious. Consider the potential drop from before the current splits to the switch arm. It should be the same regardless of which path is taken, likewise with the potential drop from the switch arm to after the current recombines. This means that the pairs of resistors R_1 and R_2 , and R_3 and R_4 , are connected in parallel. The pairs are subsequently connected in series with each other.

SKETCH:

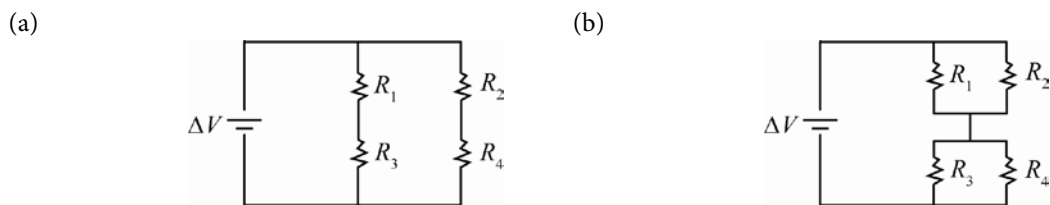

RESEARCH: Resistors in series combine as $R_{\text{eq}} = \sum_{i=1}^n R_i$. Resistors in parallel combine as $\frac{1}{R_{\text{eq}}} = \sum_{i=1}^n \frac{1}{R_i}$.

The current is given by Ohm's Law $i = \Delta V / R_{\text{eq}}$.

SIMPLIFY:

(a) Equivalent resistance is $R_{\text{eq}} = \left(1/(R_1 + R_3) + 1/(R_2 + R_4) \right)^{-1} \Rightarrow i = \Delta V / R_{\text{eq}}$.

(b) Equivalent resistance is $R_{\text{eq}} = \left(1/(R_1 + R_2) \right)^{-1} + \left(1/(R_3 + R_4) \right)^{-1} \Rightarrow i = \Delta V / R_{\text{eq}}$.

CALCULATE:

$$(a) R_{\text{eq}} = \left(\frac{1}{3.00 \, \Omega + 3.00 \, \Omega} + \frac{1}{5.00 \, \Omega + 1.00 \, \Omega} \right)^{-1} = 3.00 \, \Omega; \text{ therefore, } i = \frac{24.0 \, \text{V}}{3.00 \, \Omega} = 8.00 \, \text{A}.$$

$$(b) R_{\text{eq}} = \left(\frac{1}{3.00 \, \Omega} + \frac{1}{5.00 \, \Omega} \right)^{-1} + \left(\frac{1}{3.00 \, \Omega} + \frac{1}{1.00 \, \Omega} \right)^{-1} = 2.625 \, \Omega; \text{ therefore, } i = \frac{24 \, \text{V}}{2.625 \, \Omega} = 9.1429 \, \text{A}.$$

ROUND:

$$(a) i = 8.00 \, \text{A}$$

$$(b) i = 9.14 \, \text{A}$$

DOUBLE-CHECK: Typically, when resistors are in parallel, they have a lower equivalent resistance than when in series and thus would yield a larger current, so it makes sense.

- 25.51. THINK:** The circuit can be redrawn to have $R_3 = 2.00 \, \Omega$ and $R_4 = 4.00 \, \Omega$ in series, which are then parallel to $R_2 = 6.00 \, \Omega$. These are then in series with $R_1 = 6.00 \, \Omega$, $R_5 = 3.00 \, \Omega$, and the battery $V = 12.0 \, \text{V}$. Since R_5 is in series with the equivalent resistance, the current through it is the same as the current through the whole circuit. Since $R_2 = R_3 + R_4$, the current through each branch is equal, and half of the total current.

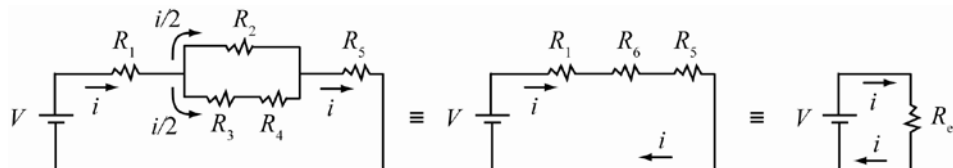
SKETCH:

RESEARCH: Resistors in series $R_{\text{eq}} = R_1 + R_2$. Resistors in parallel $R_{\text{eq}} = (1/R_1 + 1/R_2)^{-1}$. The current is given by Ohm's Law $i = \Delta V / R_{\text{eq}}$.

SIMPLIFY:

$$(a) \text{ The resistors in parallel combine as } R_6, \text{ where } R_6 = \left(\frac{1}{R_2} + \frac{1}{R_3 + R_4} \right)^{-1}.$$

The total equivalent resistance is $R_{\text{eq}} = R_1 + R_6 + R_5$.

$$(b) \text{ The current through } R_5 \text{ is } i = V / R_{\text{eq}}.$$

$$(c) \text{ The current through each branch is } i/2, \text{ so potential across } R_3 \text{ is } \Delta V_3 = \frac{1}{2} i R_3.$$

CALCULATE:

$$(a) R_6 = \left[\frac{1}{6.00 \, \Omega} + \frac{1}{(2.00 + 4.00) \, \Omega} \right]^{-1} = 3.00 \, \Omega. \quad R_{\text{eq}} = 6.00 \, \Omega + 3.00 \, \Omega + 3.00 \, \Omega = 12.00 \, \Omega$$

$$(b) i = (12.0 \, \text{V}) / (12.0 \, \Omega) = 1.00 \, \text{A}$$

$$(c) \Delta V_3 = \Delta V = \frac{(1.00 \, \text{A})(2.00 \, \Omega)}{2} = 1.00 \, \text{V}$$

ROUND:

$$(a) R_{\text{eq}} = 12.00 \, \Omega$$

$$(b) i = 1.00 \, \text{A}$$

$$(c) \Delta V_3 = 1.00 \, \text{V}$$

DOUBLE-CHECK: By considering the potential drop across R_1, R_2 , and R_5 , the values are: $\Delta V_1 = 6 \, \text{V}$, $\Delta V_2 = 3 \, \text{V}$, and $\Delta V_5 = 3 \, \text{V}$. Hence, $\Delta V_1 + \Delta V_2 + \Delta V_5 = 12 \, \text{V}$. This value matches the total voltage provided by the battery. Using $\Delta V_3 + \Delta V_4$ instead of ΔV_2 also gives $12 \, \text{V}$, as expected.

- 25.52. **THINK:** The circuit can be redrawn to have R_0 and R_1 in series, which are then parallel to R_1 . These are then in series with R_1 .

SKETCH:

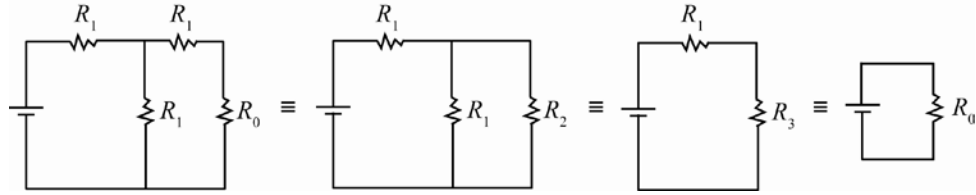

RESEARCH: Resistors in series combine as $R_{\text{eq}} = \sum_{i=1}^n R_i$. Resistors in parallel combine as $\frac{1}{R_{\text{eq}}} = \sum_{i=1}^n \frac{1}{R_i}$.

SIMPLIFY: Resistance R_2 is $R_2 = R_1 + R_0$. Resistance R_3 is $R_3 = \left(\frac{1}{R_1} + \frac{1}{R_1 + R_0} \right)^{-1}$. Equivalent resistance

$$R_0 \text{ is } R_0 = R_1 + R_3 = R_1 + \left(\frac{1}{R_1} + \frac{1}{R_1 + R_0} \right)^{-1}. \text{ Thus, } R_0 - R_1 = \frac{1}{\frac{1}{R_1} + \frac{1}{R_0 + R_1}} = \left(\frac{R_1 + R_0 + R_1}{R_1(R_1 + R_0)} \right)^{-1}.$$

$$R_0 - R_1 = \frac{R_1^2 + R_1 R_0}{2R_1 + R_0} \Rightarrow (R_0 - R_1)(2R_1 + R_0) = R_1^2 + R_1 R_0 \Rightarrow R_0^2 + R_1 R_0 - 2R_1^2 = R_1^2 + R_1 R_0$$

$$R_0^2 = 3R_1^2 \Rightarrow R_1 = \frac{R_0}{\sqrt{3}}.$$

CALCULATE: Not applicable.

ROUND: Not applicable.

DOUBLE-CHECK: If $R_1 = R_0$, the total equivalent resistance would be $5R_0/3$. If $R_1 = R_0/2$, the total equivalent resistance would be $7R_0/8$. Therefore, for $R_{\text{eq}} = R_0$, $R_0/2 < R_1 < R_0$. The answer satisfies this condition.

- 25.53. **THINK:** From the circuit, it is clear that resistors $R_1 = 5.00 \Omega$ and $R_2 = 10.00 \Omega$ are in series. Resistors $R_3 = R_4 = 5.00 \Omega$ are in parallel, with equivalent resistance R_{34} . This is also true of resistors $R_5 = R_6 = 2.00 \Omega$, whose equivalent resistance is R_{56} . This second pair of resistors are in turn connected in series with resistors R_1 and R_2 . Ohm's Law can be used to determine the current through the whole circuit which is the same as each resistor in series.

SKETCH:

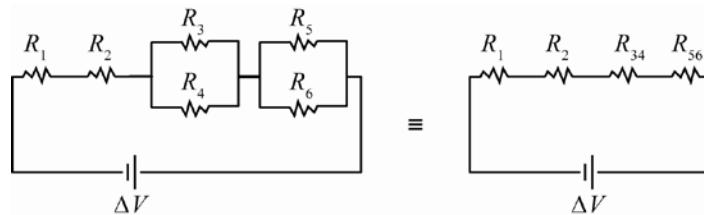

RESEARCH: Equivalent resistances if resistors are in parallel are $R_{34} = (1/R_3 + 1/R_4)^{-1}$. Total current through 4 resistors in series is $i = \Delta V / (R_1 + R_2 + R_{34} + R_{56})$. The potential drop across a resistor is $\Delta V_i = iR_i$.

SIMPLIFY:

(a) The total current is $i = \Delta V / (R_1 + R_2 + R_{34} + R_{56})$, $\Delta V_1 = iR_1$, $\Delta V_2 = iR_2$, $\Delta V_3 = \Delta V_4 = iR_{34}$ and $\Delta V_5 = \Delta V_6 = iR_{56}$.

(b) Current through R_1 and R_2 is i . Since $R_3 = R_4$ and $R_5 = R_6$, the current splits evenly among them so $i' = i/2$ through each of them.

CALCULATE:

$$(a) R_{34} = \left(1/(5.00 \Omega) - 1/(5.00 \Omega)\right)^{-1} = 2.50 \Omega \quad R_{56} = \left(1/(2.00 \Omega) - 1/(2.00 \Omega)\right)^{-1} = 1.00 \Omega,$$

$$i = 20.0 \text{ V} / (5.00 \Omega + 10.00 \Omega + 2.50 \Omega + 1.00 \Omega) = 1.08108 \text{ A}, \quad \Delta V_1 = (1.08108 \text{ A})(5.00 \Omega) = 5.405 \text{ V},$$

$$\Delta V_2 = (1.08108 \text{ A})(10.0 \Omega) = 10.81 \text{ V}, \quad \Delta V_3 = \Delta V_4 = (1.08108 \text{ A})(2.50 \Omega) = 2.702 \text{ V} \text{ and}$$

$$\Delta V_5 = \Delta V_6 = (1.08108 \text{ A})(1.00 \Omega) = 1.081 \text{ V}$$

$$(b) i_1 = i_2 = 1.08108 \text{ A}, \quad i_3 = i_4 = i_5 = i_6 = 1.08108 / 2 = 0.5405 \text{ A}$$

ROUND:

$$(a) \Delta V_1 = 5.41 \text{ V}, \quad \Delta V_2 = 10.8 \text{ V}, \quad \Delta V_3 = \Delta V_4 = 2.70 \text{ V} \text{ and } \Delta V_5 = \Delta V_6 = 1.08 \text{ V}.$$

$$(b) i_1 = i_2 = 1.08 \text{ A} \text{ and } i_3 = i_4 = i_5 = i_6 = 0.541 \text{ A}.$$

DOUBLE-CHECK: The sum of the four potential drops equals 20 V, so energy is conserved, so the answers make sense.

- 25.54. THINK:** Ohm's law can be used to relate the potential drop, $\Delta V = 40.0 \text{ V}$, to current $i_1 = 10.0 \text{ A}$ when resistors R_1 and R_2 are in series and to current $i_2 = 50.0 \text{ A}$ when the resistors are in parallel. This means there are two equations (the series and parallel configurations) and two unknowns (the resistors). Let R_1 be the one that is larger, since the choice is arbitrary, and solve for it.

SKETCH:

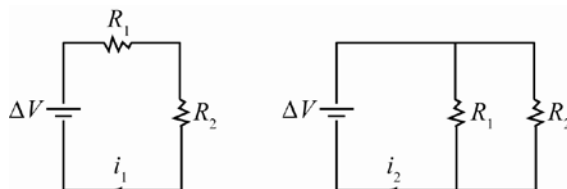

RESEARCH: For the series setup, $\Delta V = i_1(R_1 + R_2)$. For the parallel setup, $\Delta V = i_2(1/R_1 + 1/R_2)^{-1}$.

SIMPLIFY: The second resistor is, from series setup, $\Delta V = i_1(R_1 + R_2) \Rightarrow R_2 = (\Delta V / i_1) - R_1$ and

$$\frac{\Delta V}{i} = R_1 + R_2. \text{ From the parallel setup, } \Delta V = i_2 \left(\frac{R_1 R_2}{R_1 + R_2} \right) = \frac{\Delta V}{i_2} (R_1 + R_2) = R_1 \left(\frac{\Delta V}{i_2} - R_1 \right). \text{ Therefore,}$$

$$\frac{\Delta V^2}{i_1 i_2} = \frac{\Delta V}{i_1} R_1 - R_1^2 \Rightarrow P = S R_1 - R_1^2.$$

$$\text{With } P = \frac{\Delta V^2}{i_1 i_2}, \text{ and } S = \frac{\Delta V}{i_1}, \quad R_1^2 - S R_1 + P = 0 \Rightarrow R_1 = \frac{S \pm \sqrt{S^2 - 4P}}{2}. \quad R_1 \text{ must be positive to get the}$$

$$\text{largest possible value, so } R_1 = \frac{S + \sqrt{S^2 - 4P}}{2}.$$

$$\text{CALCULATE: } P = \frac{(40.0 \text{ V})^2}{(10.0 \text{ A})(50.0 \text{ A})} = 3.2 \Omega^2, \quad \text{and } S = \frac{40.0 \text{ V}}{10.0 \text{ A}} = 4 \Omega. \quad \text{Therefore,}$$

$$R_1 = \frac{(4 \Omega) + \sqrt{(4 \Omega)^2 - 4(3.2 \Omega^2)}}{2} = 2.8944 \Omega.$$

ROUND: $R_1 = 2.89 \Omega$

DOUBLE-CHECK: The other value for R_1 , the negative in the quadratic, gives $R_1 = 1.11 \Omega$, so R_{eq} in series and parallel is 4Ω and 0.8Ω , respectively. $(4 \Omega)(10.0 \text{ A}) = 40 \text{ V}$ and $(0.8 \Omega)(50.0 \text{ A}) = 40 \text{ V}$, which is consistent with emf voltage.

- 25.55. The voltage changes, from $\Delta V_0 = 110. \text{ V}$ to $\Delta V_1 = 150. \text{ V}$, and the initial power is $P_0 = 100. \text{ W}$. Since the resistance does not change, the power is, generally, $P = \Delta V^2 / R$, so the fractional change in power is $\%P = \frac{P_1 - P_0}{P_0} = \frac{\Delta V_1^2 / R - \Delta V_0^2 / R}{\Delta V_0^2 / R} = \frac{\Delta V_1^2}{\Delta V_0^2} - 1 = \frac{(150 \text{ V})^2}{(110 \text{ V})^2} - 1 = 0.8595$. Therefore, $\%P = 86.0\%$ (brighter).
- 25.56. (a) The average current, i , is simply the change in charge, $\Delta Q = 5.00 \text{ C}$, over change in time, $\Delta t = 0.100 \text{ ms}$. $i = \frac{\Delta Q}{\Delta t} = \frac{(5.00 \text{ C})}{(0.100 \cdot 10^{-3} \text{ s})} = 50.0 \text{ kA}$.
- (b) If over the lightning bolt there is a $V = 70.0 \text{ MV}$ potential, the power is $P = iV = (50.0 \text{ kA})(70.0 \text{ MV}) = 3.50 \cdot 10^{12} \text{ W}$
- (c) The energy is the power times the change in time, $E = P\Delta t = (3.50 \cdot 10^{12} \text{ W})(0.100 \text{ ms}) = 3.50 \cdot 10^8 \text{ J}$.
- (d) Assuming the lightning obeys Ohm's Law, the resistance is $R = \Delta V / i = \frac{70.0 \text{ MV}}{50.0 \text{ kA}} = 1.40 \cdot 10^3 \Omega$.
- 25.57. (a) If the hair dryer has power $P = 1600. \text{ W}$ and requires a potential of $V = 110. \text{ V}$, the current supplied is then $i = P / V = 1600. \text{ W} / 110. \text{ V} = 14.545 \text{ A} = 14.5 \text{ A}$. i does not exceed 15.0 A , so it will not trip the circuit.
- (b) Assuming the hair dryer obeys Ohm's Law, its effective resistance is given by $R = \Delta V / i = (110. \text{ V}) / (14.545 \text{ A}) = 7.56 \Omega$.
- 25.58. For a year of use, the time it is active is $\Delta t = (1 \text{ year})(365 \text{ days / year})(24 \text{ hours / day}) = 8760 \text{ h}$. The power of a regular light bulb is $P = 100.00 \text{ W} = 0.10000 \text{ kW}$. The power of the fluorescent bulb is $P_F = 26.000 \text{ W} = 0.026000 \text{ kW}$. Since it costs $\$0.12 / \text{kWh}$ to have each on, the cost of running each is: $C = (\$0.12 / \text{kWh})(0.10000 \text{ kW})(8760 \text{ h}) = \105.12 , $C_F = (\$0.12 / \text{kWh})(0.026 \text{ kW})(8760 \text{ h}) = \27.33 .
- 25.59. To find the current through each, reduce circuit to

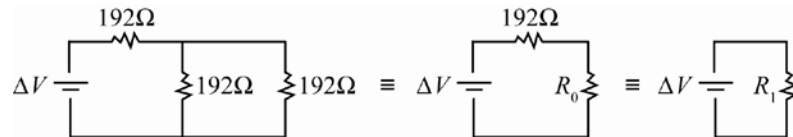

- (a) The two 192Ω resistors in parallel have an equivalent resistance given by

$$\frac{1}{R_0} = \frac{1}{192 \Omega} + \frac{1}{192 \Omega} = \frac{2}{192 \Omega} \Rightarrow R_0 = 96.0 \Omega$$

The resistance R_0 is in series with another 192Ω resistor. This system has the equivalent resistance given by

$$R_1 = R_0 + 192 \Omega = 96.0 \Omega + 192 \Omega = 288 \Omega$$

The total power in the circuit is given by

$$P = \frac{(\Delta V)^2}{R_1} = \frac{(120. \text{ V})^2}{288 \Omega} = 50.0 \text{ W}$$

- (b) The current supplied by the emf source is given by

$$\Delta V = iR_1 \Rightarrow i = \frac{\Delta V}{R_1} = \frac{120. \text{ V}}{288 \Omega} = 0.4167 \text{ A}$$

This current flows through the first resistor. So the potential drop across the first resistor is

$$\Delta V_1 = (0.4167 \text{ A})(192 \Omega) = 80.0 \text{ V}$$

The remaining two resistors are in parallel, so the potential drop across each of these two resistors must sum to the potential difference of the source of emf

$$\Delta V_2 = \Delta V_3 = 120. \text{ V} - 80.0 \text{ V} = 40.0 \text{ V}.$$

- 25.60.** The current through the light bulb is $i = P/V$. The charge through the bulb is $q = i\Delta t$, so

$$q = i\Delta t = \frac{P\Delta t}{\Delta V} \Rightarrow \Delta t = \frac{q\Delta V}{P} = \frac{(625 \text{ mAh}) \left(\frac{1 \text{ A}}{1000 \text{ mA}} \right) \left(\frac{60 \text{ min}}{\text{h}} \right) (1.5 \text{ V})}{5.0 \text{ W}} = 11 \text{ min}.$$

- 25.61. THINK:** The overall current through the resistor, R (which takes the values 1.00Ω , 2.00Ω and 3.00Ω), is found using Ohm's Law for when the load resistance is in series with the internal resistance, $R_i = 2.00 \Omega$, and the external emf, $V_{\text{emf}} = 12.0 \text{ V}$. I will determine an expression for the power across the load resistor and differentiate with respect to R , and solve this derivative equal to zero, in order to find a maximum in power.

SKETCH:

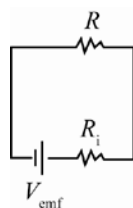

RESEARCH: With R and R_i in series, current through circuit is $i = V_{\text{emf}} / (R_i + R)$. Power through load resistor is $P = i^2 R$. The power is maximized when $dP/dR = 0$ and $d^2P/dR^2 < 0$.

SIMPLIFY: Power is $P = \left(\frac{V_{\text{emf}}}{R_i + R} \right)^2 R = \frac{V_{\text{emf}}^2}{(R_i + R)^2} R$. Therefore,

$$\begin{aligned} \frac{dP}{dR} &= V_{\text{emf}}^2 \frac{d}{dR} \left[R(R_i + R)^{-2} \right] = V_{\text{emf}}^2 \left[(R_i + R)^{-2} - 2(R)(R_i + R)^{-3} \right] \\ &= V_{\text{emf}}^2 \left[\frac{R_i + R}{(R_i + R)^3} - \frac{2R}{(R_i + R)^3} \right] = V_{\text{emf}}^2 \left[\frac{R_i - R}{(R_i + R)^3} \right] = 0, \end{aligned}$$

and hence $R = R_i$ is a critical point of P . The double-check step will verify that $R = R_i$ leads to a maximum.

CALCULATE: $P_1 = \frac{(12.0 \text{ V})^2 (1.00 \Omega)}{(1.00 \Omega + 2.00 \Omega)^2} = 16.0 \text{ W}$, $P_2 = \frac{(12.0 \text{ V})^2 (2.00 \Omega)}{(2.00 \Omega + 2.00 \Omega)^2} = 18.0 \text{ W}$ and

$$P_3 = \frac{(12.0 \text{ V})^2 (3.00 \Omega)}{(3.00 \Omega + 2.00 \Omega)^2} = 17.28 \text{ W}.$$

ROUND: The values should be rounded to three significant figures each: $P_1 = 16.0 \text{ W}$, $P_2 = 18.0 \text{ W}$ and $P_3 = 17.3 \text{ W}$.

DOUBLE-CHECK: The second derivative of P , $\frac{d^2P}{dR^2} = 2 \frac{V_{\text{emf}}^2 (R - 2R_i)}{(R_i + R)^4}$, is clearly negative when $R = R_i$, which verifies that $R = R_i$ yields a maximum for P .

- 25.62. THINK:** Using the density and volume of water, $\rho = 1000 \text{ kg/m}^3$ and $V = 250 \text{ mL}$, the mass of the water can be determined. Along with the specific heat of water, $c = 4.186 \text{ kJ}/(\text{kg K})$, and the fact that the water goes from $T_i = 20 \text{ }^\circ\text{C} = 293 \text{ K}$ to $T_f = 100 \text{ }^\circ\text{C} = 373 \text{ K}$ the energy gained by the water can be determined.

The change in energy over the time $\Delta t = 45$ s is equal to the power that the coil, $\Delta V = 15$ V, dissipates.

SKETCH:

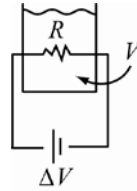

RESEARCH: Power dissipated by coil is $P = \Delta V^2 / R$. The energy gained by heating water, $\Delta Q = mc\Delta T$. The rate of energy gained by water is $P = \Delta Q / \Delta t$, mass of water is $m = \rho V$.

SIMPLIFY: Equating power dissipated by coil to energy rate gained by water gives the equation:

$$P = \frac{\Delta V^2}{R} = \frac{\Delta Q}{\Delta t} = \frac{mc\Delta T}{\Delta t} = \frac{\rho Vc(T_f - T_i)}{\Delta t}.$$

Therefore, $R = \frac{\Delta V^2 \Delta t}{\rho Vc(T_f - T_i)}.$

CALCULATE: $R = \frac{(15 \text{ V})^2 (45 \text{ s})}{(1000 \text{ kg/m}^3)(0.25 \text{ L})(4186 \text{ J/kg K})(373 \text{ K} - 293 \text{ K})(1 \text{ m}^3/1000 \text{ L})} = 0.1209 \Omega$

ROUND: The values in the question have two significant figures, so round the answer to $R = 1.2 \text{ m}\Omega$.

DOUBLE-CHECK: Since power is inversely proportional to resistance, the optimal way to heat using it would be to make the resistance as small as possible, so it makes sense.

- 25.63. THINK:** Both the copper wire length ($l = 75.0$ cm, diameter $d = 0.500$ mm and resistivity $\rho_C = 1.69 \cdot 10^{-8} \Omega \text{ m}$) and silicon block (length $L = 15.0$ cm, width $a = 2.00$ mm, thickness b , resistivity $\rho_S = 8.70 \cdot 10^{-4} \Omega \text{ m}$ and resistance $R_S = 50.0 \Omega$) can be thought of as resistors in series with a total potential drop of $\Delta V = 0.500$ V and a density of charge carriers of $1.23 \cdot 10^{23} \text{ m}^{-3}$. The current density, J , can be used to determine the velocity of the carriers through the silicon.

SKETCH:

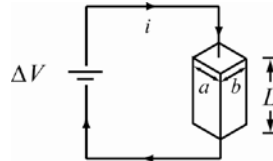

RESEARCH: The resistance of the material is in general $R = \rho L / A$. The current through circuit is found by Ohm's Law with copper wire and silicon block in series, $\Delta V = i(R_C + R_S)$. Area of the silicon block is $A = ab$. The current density is $J = i / A = nev_d$. The time it takes to pass through silicon block is $\Delta t = L / v_d$. Power dissipated by silicon block is $P_S = i^2 R_S$.

SIMPLIFY:

(a) Resistance of wire is $R_C = \frac{\rho_C l}{(1/4)\pi d^2}.$

(b) Current through circuit is $i = \frac{\Delta V}{R_C + R_S}.$

(c) Thickness of silicon block $R_S = \frac{\rho_S L}{ab} \Rightarrow b = \frac{\rho_S L}{aR_S}.$

(d) Drift velocity of electrons $J = \frac{i}{A} = nev_d \Rightarrow v_d = \frac{i}{abne}$. So the time to cross the block is

$$\Delta t = \frac{L}{v_d} = \frac{Labne}{i}.$$

(e) $P_s = i^2 R_s$

(f) Electric power is lost via heat.

CALCULATE:

(a) $R_C = \frac{(1.69 \cdot 10^{-8} \Omega \text{ m})(75.0 \text{ cm})}{(1/4)\pi(0.500 \text{ mm})^2} = 0.064553 \Omega = 64.553 \text{ m} \Omega$

(b) $i = \frac{0.500 \text{ V}}{50.0 \Omega + 0.064533 \Omega} = 0.009987 \text{ A} = 9.987 \text{ mA}$

(c) $b = \frac{(8.70 \cdot 10^{-4} \Omega \text{ m})(15.0 \text{ cm})}{(2.00 \text{ mm})(50.0 \Omega)} = 0.001305 \text{ m} = 1.305 \text{ mm}$

(d) $\Delta t = \frac{(15.0 \text{ cm})(2.00 \text{ mm})(1.305 \text{ mm})(1.23 \cdot 10^{23} \text{ m}^{-3})(1.602 \cdot 10^{-19} \text{ C})}{9.987 \text{ mA}} = 0.77243 \text{ s}$

(e) $P_s = (9.987 \text{ mA})^2 (50.0 \Omega) = 0.004987 \text{ W} = 4.987 \text{ mW}$

ROUND:

(a) $R_C = 64.6 \text{ m} \Omega$

(b) $i = 9.99 \text{ mA}$

(c) $b = 1.31 \text{ mm}$

(d) $\Delta t = 0.772 \text{ s}$

(e) $P_s = 4.99 \text{ mW}$

DOUBLE-CHECK: Drift velocity is $L / \Delta t \approx 20 \text{ cm/s}$ which is reasonable for such a small resistance. Also, the power lost is small, which is desirable in silicon, which is used in many electronic devices, so it makes sense.

25.64. Electrical power is defined as $P = i^2 R$ or $P = \Delta V^2 / R$ or $P = i \Delta V$. In the normal operation, the radio has a resistance of $r = \Delta V^2 / P = (10.0 \text{ V})^2 / (30.0 \text{ W}) = 3.33 \Omega$ and the current flowing through the radio is

$$i = \frac{P}{\Delta V} = \frac{30.0 \text{ W}}{10.0 \text{ V}} = 3.00 \text{ A}.$$

Now, if a 25.0 kV power supply is used, the required total resistance, such

that the current flowing through the radio is the same, is $R_T = \frac{\Delta V}{i} = \frac{25.0 \text{ kV}}{3.0 \text{ A}} = 8333.33 \Omega$. Thus, the

external resistance required is $R = R_T - r$. The closest number of resistors is

$$N = \frac{R}{R_1} = \frac{R_T - r}{R_1} = \frac{8333.33 \Omega - 3.33 \Omega}{25 \Omega} = 333.2 \approx 333 \text{ resistors}.$$

All resistors are connected in series, since the potential drop across the resistors makes up for the rest of the enormous potential drop provided by the power supply.

25.65. It is given $\Delta V = 120 \text{ V}$, $\Delta t = 2.0 \text{ min} = 120 \text{ s}$ and $U_1 = 48 \text{ kJ}$. The power needed to cook one hot dog is $P_1 = U_1 / \Delta t = 4.8 \cdot 10^4 \text{ J} / 120 \text{ s} = 4.0 \cdot 10^2 \text{ W}$. The current to produce this power is $i_1 = P_1 / \Delta V = 4.0 \cdot 10^2 \text{ W} / 120 \text{ V} = 3.3 \text{ A}$. The current to cook three hot dogs is $i = 3i_1 = 3(3.3 \text{ A}) = 10. \text{ A}$.

25.66. The aluminum wire and the copper wire dissipate the same power. Since the voltages across the wires are the same, this means that the resistances of the wires are the same. That is $R_{\text{Al}} = R_{\text{Cu}}$, $\frac{\rho_{\text{Al}}L_{\text{Al}}}{A_{\text{Al}}} = \frac{\rho_{\text{Cu}}L_{\text{Cu}}}{A_{\text{Cu}}}$.

Using the area of a circle $A = \pi r^2$, it is found that $\frac{r_{\text{Al}}^2}{r_{\text{Cu}}^2} = \frac{\rho_{\text{Al}}L_{\text{Al}}}{\rho_{\text{Cu}}L_{\text{Cu}}}$. Thus, $r_{\text{Al}} = r_{\text{Cu}}\sqrt{\frac{\rho_{\text{Al}}L_{\text{Al}}}{\rho_{\text{Cu}}L_{\text{Cu}}}}$. Substituting the numerical values:

$$r_{\text{Al}} = (1.00 \text{ mm})\sqrt{\frac{(2.82 \cdot 10^{-8} \text{ } \Omega \text{ m})(5.00 \text{ m})}{(1.72 \cdot 10^{-8} \text{ } \Omega \text{ m})(10.0 \text{ m})}} = 0.905 \text{ mm}.$$

25.67. The resistance of a cylindrical wire is $R = \rho L / A$. The length of the resistor is $L = RA / \rho$. Substituting the numerical values yields $L = (10.0 \text{ } \Omega)(1.00 \cdot 10^{-6} \text{ m}^2) / (1.00 \cdot 10^{-5} \text{ } \Omega \text{ m}) = 1.00 \text{ m}$.

25.68. Two resistive cylindrical wires of identical length are made of copper and aluminum. They carry the same current and have the same potential difference across their length. This means that they have the same resistance, that is, $R_{\text{Cu}} = R_{\text{Al}}$, $\frac{\rho_{\text{Al}}L_{\text{Al}}}{A_{\text{Al}}} = \frac{\rho_{\text{Cu}}L_{\text{Cu}}}{A_{\text{Cu}}}$. Since $L_{\text{Al}} = L_{\text{Cu}}$ and $A_{\text{Al}} = \pi r_{\text{Al}}^2$ and $A_{\text{Cu}} = \pi r_{\text{Cu}}^2$, it becomes

$$\frac{r_{\text{Cu}}^2}{r_{\text{Al}}^2} = \frac{\rho_{\text{Cu}}}{\rho_{\text{Al}}} \text{ or } \frac{r_{\text{Cu}}}{r_{\text{Al}}} = \sqrt{\frac{\rho_{\text{Cu}}}{\rho_{\text{Al}}}}. \text{ Therefore, the ratio of their radii is}$$

$$\frac{r_{\text{Cu}}}{r_{\text{Al}}} = \sqrt{\frac{1.72 \cdot 10^{-8} \text{ } \Omega \text{ m}}{2.82 \cdot 10^{-8} \text{ } \Omega \text{ m}}} = 0.781.$$

25.69. Consider a circuit with $R_1 = 200. \text{ } \Omega$ and $R_2 = 400. \text{ } \Omega$.

(a) What is the power dissipated in R_1 when the two resistors are connected in series?

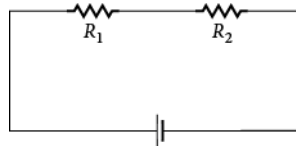

The current in the circuit is given by

$$\Delta V = iR_{\text{eq}} \Rightarrow i = \frac{\Delta V}{R_{\text{eq}}} = \frac{\Delta V}{R_1 + R_2}.$$

The power dissipated in R_1 is then

$$P = i^2 R_1 = \left(\frac{\Delta V}{R_1 + R_2} \right)^2 R_1 = \frac{R_1 (\Delta V)^2}{(R_1 + R_2)^2} = \frac{(200. \text{ } \Omega)(9.00 \text{ V})^2}{(200. \text{ } \Omega + 400. \text{ } \Omega)^2} = 0.0450 \text{ W}.$$

(b) What is the power dissipated in R_1 when the two resistors are connected in parallel?

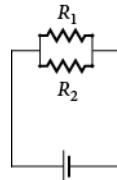

The potential difference across R_1 is 9.00 V so the power dissipated in this case is

$$P = \frac{(\Delta V)^2}{R_1} = \frac{(9.00 \text{ V})^2}{200. \text{ } \Omega} = 0.405 \text{ W}.$$

The ratio of the power delivered to the $200. \Omega$ resistor by the 9.00 V battery when the resistors are connected in parallel to the power delivered when connected in series is

$$\frac{P_{\text{parallel}}}{P_{\text{series}}} = \frac{\frac{(\Delta V)^2}{R_1}}{\frac{R_1 (\Delta V)^2}{(R_1 + R_2)^2}} = \frac{(R_1 + R_2)^2}{R_1^2} = \left(\frac{R_1 + R_2}{R_1} \right)^2 = \left(\frac{200. \Omega + 400. \Omega}{200. \Omega} \right)^2 = 9.00.$$

25.70. The conductance of a wire is given by $G = \frac{1}{R} = \frac{A}{\rho L}$.

(a) From the electrical power $P = \frac{\Delta V^2}{R}$, the conductance of the element is

$$G = \frac{P}{\Delta V^2} = \frac{1500. \text{ W}}{(110. \text{ V})^2} = 0.124 \Omega^{-1}.$$

(b) Using $A = \pi r^2$, the radius of the wire is $r^2 = \frac{\rho L G}{\pi}$ or $r = \sqrt{\frac{\rho L G}{\pi}}$. Substituting $\rho = 9.7 \cdot 10^{-8} \Omega \text{ m}$,

$L = 3.5 \text{ m}$ and $G = 0.124 \Omega^{-1}$ gives

$$r = \sqrt{\frac{(9.7 \cdot 10^{-8} \Omega \text{ m})(3.50 \text{ m})(0.124 \Omega^{-1})}{\pi}} = 0.116 \text{ mm}.$$

25.71. The resistance of the light bulb is $R = \Delta V_1^2 / P_1$. Consider each value in the problem to have three significant figures. The power consumed by the bulb in a US household is

$$P_2 = \frac{\Delta V_2^2}{R} = \left(\frac{\Delta V_2}{\Delta V_1} \right)^2 P_1 = \left(\frac{120. \text{ V}}{240. \text{ V}} \right)^2 (100. \text{ W}) = 25.0 \text{ W}.$$

25.72. (a) The minimum overall resistance is $R = \Delta V / i = 115 \text{ V} / 200. \text{ A} = 0.575 \Omega$.

(b) The maximum electrical power is $P = i \Delta V = (200. \text{ A})(115 \text{ V}) = 23.0 \text{ kW}$.

25.73. THINK: A battery with emf 12.0 V and internal resistance $R_i = 4.00 \Omega$ is attached across an external resistor of resistance R . The maximum power that can be delivered to the resistor R is required.

SKETCH:

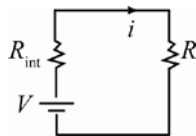

RESEARCH: The power delivered to the resistor R is given by $P = i^2 R$. The current flowing through the circuit is $i = \Delta V / (R + R_i)$. Therefore, the power is $P = \Delta V^2 R / (R + R_i)^2$. The maximum power delivered to the resistor R is given when R satisfies $dP / dR = 0$. That is

$$\frac{dP}{dR} = \frac{\Delta V^2}{(R + R_i)^2} + \frac{\Delta V^2 R (-2)}{(R + R_i)^3} = 0.$$

SIMPLIFY: Solving the above equation for R yields $R + R_i - 2R = 0$ or $R = R_i$. Thus, the maximum

power delivered to R is $P = \frac{\Delta V^2 R_i}{(2R_i)^2} = \frac{\Delta V^2}{4R_i}$.

CALCULATE: Substituting the numerical values gives $P = \frac{(12.0 \text{ V})^2}{4(4.00 \Omega)} = 9.00 \text{ W}$.

ROUND: $P = 9.00 \text{ W}$

DOUBLE-CHECK: This is a reasonable amount of power for a 12 V battery to supply.

- 25.74. THINK:** Calculate the resistance of a 10.0 m length of multilayered wire consisting of a zinc core of radius 1.00 mm surrounded by a copper sheath of thickness 1.00 mm. The wire can be treated as two resistors in parallel.

SKETCH:

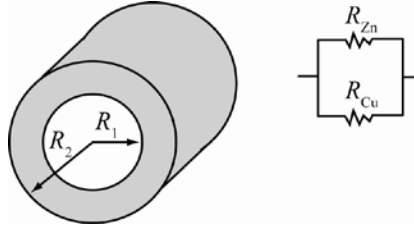

RESEARCH: The resistivity of zinc is $\rho_{\text{Zn}} = 5.964 \cdot 10^{-8} \Omega \text{ m}$, and the resistivity of copper is $\rho_{\text{Cu}} = 1.72 \cdot 10^{-8} \Omega \text{ m}$. Resistance is given by $R = \rho \frac{L}{A}$. The resistance of the zinc wire is therefore $R_{\text{Zn}} = \frac{\rho_{\text{Zn}} L}{\pi R_1^2}$, and the resistance of the hollow copper wire is $R_{\text{Cu}} = \frac{\rho_{\text{Cu}} L}{\pi R_2^2 - \pi R_1^2}$. The net resistance is $1/R = 1/R_{\text{Zn}} + 1/R_{\text{Cu}}$.

SIMPLIFY:
$$R_{\text{eq}} = \left(\frac{1}{R_{\text{Zn}}} + \frac{1}{R_{\text{Cu}}} \right)^{-1} = \left(\frac{R_{\text{Cu}} + R_{\text{Zn}}}{R_{\text{Zn}} R_{\text{Cu}}} \right)^{-1} = \frac{R_{\text{Cu}} R_{\text{Zn}}}{R_{\text{Cu}} + R_{\text{Zn}}} = \frac{\frac{\rho_{\text{Cu}} L}{A_{\text{Cu}}} \cdot \frac{\rho_{\text{Zn}} L}{A_{\text{Zn}}}}{\frac{\rho_{\text{Cu}} L}{A_{\text{Cu}}} + \frac{\rho_{\text{Zn}} L}{A_{\text{Zn}}}}$$

$$R_{\text{eq}} = \frac{\frac{\rho_{\text{Zn}} L}{\pi r_1^2} \cdot \frac{\rho_{\text{Cu}} L}{\pi (R_2^2 - R_1^2)}}{\frac{\rho_{\text{Cu}} L}{\pi (R_2^2 - R_1^2)} + \frac{\rho_{\text{Zn}} L}{\pi R_1^2}} = \frac{L(\rho_{\text{Zn}} \rho_{\text{Cu}})}{\pi (\rho_{\text{Cu}} r_1^2 + \rho_{\text{Zn}} (R_2^2 - R_1^2))}$$

CALCULATE:

$$R_{\text{eq}} = \frac{10.0 \text{ m} (1.72 \cdot 10^{-8} \Omega \text{ m}) (5.964 \cdot 10^{-8} \Omega \text{ m})}{\pi \left((1.72 \cdot 10^{-8} \text{ m}) (1.00 \cdot 10^{-3} \text{ m})^2 + (5.964 \cdot 10^{-8} \Omega \text{ m}) \left((2.00 \cdot 10^{-3} \text{ m})^2 - (1.00 \cdot 10^{-3} \text{ m})^2 \right) \right)}$$

$$= 0.01664925 \Omega$$

ROUND: Keeping only three significant digits gives $R = 0.0166 \Omega$.

DOUBLE-CHECK: The combined resistance of the components of the wire is less than the resistance of either material alone, as expected for resistances in parallel.

- 25.75. THINK:** The Stanford Linear Accelerator accelerated a beam of $2.0 \cdot 10^{14}$ electrons per second through a potential difference of $2.0 \cdot 10^{10} \text{ V}$.

SKETCH: Not required.

RESEARCH: Electrical current is defined by $i = q/t$, i.e. the amount of charging passing per unit of time. The power in the beam is calculated by $P = i\Delta V$ and the effective ohmic resistance is $R = \Delta V / i$.

SIMPLIFY:

(a) The electrical current in the beam is $i = q/t = |e|(n/t)$.

(b) The power in the beam is $P = i\Delta V$.

(c) The effective resistance is $R = \Delta V / i$.

CALCULATE:

(a) $i = (1.602 \cdot 10^{-19} \text{ C})(2.0 \cdot 10^{14} \text{ electrons/second}) = 3.204 \cdot 10^{-5} \text{ A}$.

(b) $P = (3.204 \cdot 10^{-5} \text{ A})(2.0 \cdot 10^{10} \text{ V}) = 640.8 \text{ kW}$.

(c) $R = \frac{2.0 \cdot 10^{10} \text{ V}}{3.204 \cdot 10^{-5} \text{ A}} = 6.2422 \cdot 10^{14} \Omega$.

ROUND: Keeping only two significant digits, the results become,

(a) $i = 3.2 \cdot 10^{-5} \text{ A}$

(b) $P = 640 \text{ kW}$

(c) $R = 6.2 \cdot 10^{14} \Omega$

DOUBLE-CHECK: Such large values are reasonable for a device meant to accelerate particles to relativistic speeds.

- 25.76. **THINK:** To solve this problem, the circuit needs to be simplified by finding equivalent resistances. Use the relationships of parallel and series resistors.

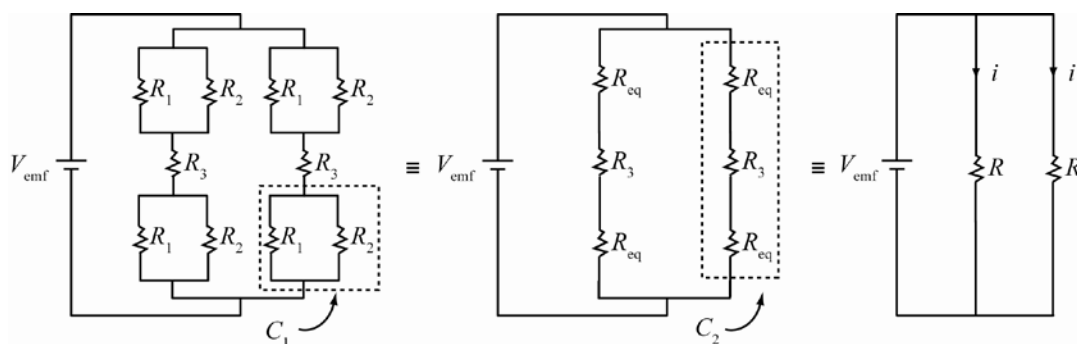
SKETCH:

RESEARCH: If two resistors in series, the equivalent resistance is $R_{\text{eq}} = R_A + R_B$, and if two resistors in parallel, the equivalent resistances is $1/R_{\text{eq}} = 1/R_A + 1/R_B$ or $R_{\text{eq}} = R_A R_B / (R_A + R_B)$.

SIMPLIFY: The equivalent resistance of two resistors in the circuit C_1 is $R_{\text{eq}} = R_1 R_2 / (R_1 + R_2)$. The equivalent resistance of three resistors in the circuit C_2 is $R = R_{\text{eq}} + R_3 + R_{\text{eq}} = 2R_{\text{eq}} + R_3 = 2R_1 R_2 / (R_1 + R_2) + R_3$. Thus, the effective resistance is given by

$$\frac{1}{R_{\text{eff}}} = \frac{1}{R} + \frac{1}{R} \Rightarrow R_{\text{eff}} = \frac{1}{2}R = \frac{R_1 R_2}{R_1 + R_2} + \frac{1}{2}R_3.$$

 The current flowing through R_3 is the same as current through R . Therefore, $i = \frac{V_{\text{emf}}}{R} = \frac{V_{\text{emf}}}{2R_{\text{eff}}}$.

CALCULATE:

(a) $R_{\text{eff}} = \frac{(3.00 \Omega)(6.00 \Omega)}{3.00 \Omega + 6.00 \Omega} + \frac{20.0 \Omega}{2} = 10.0 \Omega$

(b) $i = \frac{12.0 \text{ V}}{2(10.0 \Omega)} = 0.500 \text{ A}$

ROUND: Not required.

DOUBLE-CHECK: Both of the calculated values have appropriate units for what the values represent.

- 25.77. **THINK:** For resistors connected in parallel, the potential differences across the resistors are the same.
SKETCH:

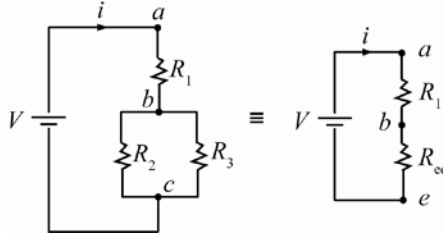

RESEARCH: The equivalent resistance of two resistors in parallel (R_2 and R_3) is $R_{\text{eq}} = (R_2)(R_3)/(R_2 + R_3)$.

SIMPLIFY:

- (a) The potential difference across R_3 is $V_{bc} = V_{ac} - V_{ab} = V - iR_1 = V \left(\frac{R_1}{R_1 + R_{\text{eq}}} \right)$.
- (b) Since R_1 and R_{eq} are in series, the current flowing through R_1 and R_{eq} is $i = \frac{V}{R_1 + R_{\text{eq}}}$.
- (c) The rate thermal energy dissipated from R_2 is $P = \frac{V_{bc}^2}{R_2}$.

CALCULATE: $R_{\text{eq}} = \frac{(3.00 \Omega)(6.00 \Omega)}{3.00 \Omega + 6.00 \Omega} = 2.00 \Omega$

- (a) The potential difference across R_3 is $V_{bc} = 110. \text{ V} \left(\frac{2.00 \Omega}{2.00 \Omega + 2.00 \Omega} \right) = 55.0 \text{ V}$.
- (b) The current through R_1 is $i = \frac{110. \text{ V}}{2.00 \Omega + 2.00 \Omega} = 27.5 \text{ A}$.
- (c) The thermal energy dissipated from R_2 is $P = \frac{(55.0 \text{ V})^2}{3.00 \Omega} = 1.008 \text{ kW}$.

ROUND: Keeping three significant digits gives:

- (a) $V_{bc} = 55.0 \text{ V}$
 (b) $i = 27.5 \text{ A}$
 (c) $P = 1.01 \text{ kW}$

DOUBLE-CHECK: Each value has appropriate units for what is being measured.

- 25.78. **THINK:** When a potential difference V is applied across resistors connected in series, the resistors have identical currents. The potential difference across R_1 is $V_{ac} = V$.

SKETCH:

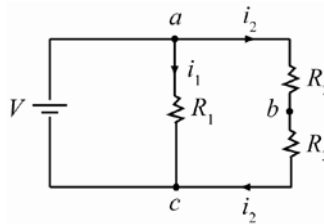

RESEARCH:

$V_{ac} = V_{ab} + V_{bc}$; The potential differences across R_1 , R_2 and R_3 are $V_{ab} = i_2 R_2 = \frac{VR_2}{R_2 + R_3}$ and

$V_{bc} = i_2 R_3 = \frac{VR_3}{R_2 + R_3}$, respectively. The currents are: $i_1 = \frac{V}{R_1}$ and $i_2 = i_3 = \frac{V}{R_2 + R_3}$.

SIMPLIFY: Not required.

CALCULATE: Substituting the values of the resistors and the potential difference across the battery yields

$$(a) \quad V_{ac} = 1.500 \text{ V}, \quad V_{ab} = \frac{(1.500 \text{ V})(4.00 \Omega)}{4.00 \Omega + 6.00 \Omega} = 0.600 \text{ V}, \quad \text{and}$$

$$V_{bc} = V_{ac} - V_{ab} = 1.500 \text{ V} - 0.600 \text{ V} = 0.900 \text{ V}.$$

$$(b) \quad i_1 = \frac{1.500 \text{ V}}{2.00 \Omega} = 0.750 \text{ A} \quad \text{and} \quad i_2 = i_3 = \frac{1.500 \text{ V}}{4.00 \Omega + 6.00 \Omega} = 0.150 \text{ A}.$$

ROUND: Keeping three significant figures gives:

$$(a) \quad V_{ac} = 1.500 \text{ V}, \quad V_{ab} = 0.600 \text{ V} \quad \text{and} \quad V_{bc} = 0.900 \text{ V}.$$

$$(b) \quad i_1 = 0.750 \text{ A} \quad \text{and} \quad i_2 = i_3 = 0.150 \text{ A}.$$

DOUBLE-CHECK: The resistance through the right path is five times larger than the resistance through the center path. Therefore the current should be five times smaller in the right path, which the calculation shows before rounding for significant figures.

- 25.79. THINK:** In order for a copper cable to start melting, its temperature must be increased to a melting point temperature, which for copper is 1359 K (Table 18.2). Copper has a specific heat of 386 J/kg K (Table 18.1) and a mass density of 8960 kg/m³. The cable is insulated. This means the energy dissipated by the cable is used to increase its temperature. Use $L = 2.5$ m, and $V = 12$ V.

SKETCH:

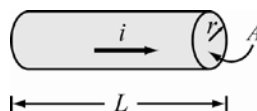

RESEARCH: The resistance of the copper cable is $R = \rho \frac{L}{A}$. The energy dissipated by the cable is

$E = P \cdot \Delta t = \left(\frac{V^2}{R} \right) \Delta t = \left(\frac{V^2 A}{\rho L} \right) \Delta t$. This energy must be equal to the amount of heat required to increase the temperature of the cable from the room temperature to the melting point temperature, which is $Q = cm(T_M - T_R) = cm\Delta T$, where c is the specific heat of copper.

SIMPLIFY: Using the mass of the copper cable given by $m = \rho_D AL$, the time required to start melting the

cable is $\left(\frac{V^2 A}{\rho L} \right) \Delta t = c \rho_D AL \Delta T \Rightarrow \Delta t = \frac{c \rho_D \rho L^2 \Delta T}{V^2}$.

$$\text{CALCULATE: } \Delta t = \frac{(386 \text{ J/kg K})(8960 \text{ kg/m}^3)(1.72 \cdot 10^{-8} \Omega \text{ m})(2.5 \text{ m})^2 (1359 \text{ K} - 300 \text{ K})}{(12.0 \text{ V})^2} = 2.734 \text{ s}$$

ROUND: Rounding Δt to three significant digits produces $\Delta t = 2.73$ s.

DOUBLE-CHECK: This is a short time interval, but the 12 V battery supplies a large voltage, and the insulation does not allow the heat of the wire to dissipate.

- 25.80. THINK:** A piece of copper wire is used to form a circular loop of radius 10 cm. The cross-sectional area of the wire is 10 mm^2 . The resistance between two points on the wire is needed.

SKETCH:

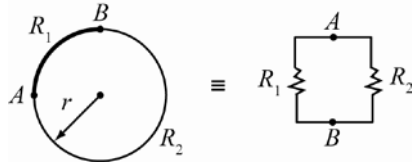

RESEARCH: The resistance of a wire is given by $R = \rho L / A$. Thus, the resistances of each segment of the wire are $R_1 = \rho L_1 / A$ and $R_2 = \rho L_2 / A$.

SIMPLIFY: Since $L_2 = 3L_1$, the resistance R_2 is $R_2 = \rho 3L_1 / A = 3R_1$. Because R_1 and R_2 are in parallel, the effective resistance is $R = \frac{R_1 R_2}{R_1 + R_2} = \frac{3R_1^2}{R_1 + 3R_1} = \frac{3}{4} R_1 = \frac{3}{4} \frac{\rho L_1}{A}$. Putting in $L_1 = \frac{1}{4} \cdot 2\pi r$ gives $R = \frac{3}{8} \cdot \frac{\rho \pi r}{A}$.

CALCULATE: $R = \frac{3}{8} \left(1.72 \cdot 10^{-8} \Omega \text{ m} \right) \frac{\pi (0.100 \text{ m})}{1.00 \cdot 10^{-5} \text{ m}^2} = 2.03 \cdot 10^{-4} \Omega$

ROUND: $R = 2.03 \cdot 10^{-4} \Omega$

DOUBLE-CHECK: The resistance of L_1 is

$$R_1 = \rho L_1 / A = \left(1.72 \cdot 10^{-8} \Omega \text{ m} \right) \frac{2\pi (10 \cdot 10^{-2} \text{ m})}{4 (10 \cdot 10^{-6} \text{ m}^2)} = 2.702 \cdot 10^{-4} \Omega.$$

The resistance of L_2 is $R_2 = 3R_1 = 8.105 \cdot 10^{-4} \Omega$. Our result is less than R_1 and R_2 , because the two resistances are in parallel. So our answer seems reasonable.

- 25.81. THINK:** Two conducting wires have identical length and identical radii of circular cross-sections. I want to calculate the ratio of the power dissipated by the two resistors (copper and steel).

SKETCH: Not required.

RESEARCH: The resistance of a wire is given by $R = \rho L / A$. The power dissipated by the wire is

$$P = \frac{V^2}{R} = \frac{V^2 A}{\rho L}.$$

SIMPLIFY: Therefore, the ratio of powers of two wires is

$$\frac{P_{\text{copper}}}{P_{\text{steel}}} = \left(\frac{V^2 A_{\text{copper}}}{\rho_{\text{copper}} L_{\text{copper}}} \right) \div \left(\frac{V^2 A_{\text{steel}}}{\rho_{\text{steel}} L_{\text{steel}}} \right).$$

Since $L_{\text{copper}} = L_{\text{steel}}$ and $A_{\text{copper}} = A_{\text{steel}}$, the ratio becomes $\frac{P_{\text{copper}}}{P_{\text{steel}}} = \frac{\rho_{\text{steel}}}{\rho_{\text{copper}}}$.

CALCULATE: $\frac{P_{\text{copper}}}{P_{\text{steel}}} = \frac{40.0 \cdot 10^{-8} \Omega \text{ m}}{1.68 \cdot 10^{-8} \Omega \text{ m}} = 23.8095$

ROUND: Rounding the result to three significant digits yields a ratio of 23.8:1. This is because copper is a better conducting material than steel. Moreover, the specific heat of copper is less than steel. This means that copper is less susceptible to heat than steel.

DOUBLE-CHECK: Since the two wires have identical dimensions, and the power dissipated is inversely proportional to the resistivity of the wires, it is reasonable that the material with the higher resistivity dissipates the larger amount of power.

25.82. THINK: The resistance of a wire increases or decreases linearly as a function of temperature.

SKETCH: Not required.

RESEARCH: The resistance of the wire at temperature T is given by $R = R_0(1 + \alpha(T - T_0))$. The resistance at temperature T is $R = V^2 / P$.

SIMPLIFY: The resistance at the temperature T_0 becomes $R_0 = (V^2 / P)[1 + \alpha(T - T_0)]^{-1}$.

CALCULATE: Substituting $T = 20^\circ\text{C}$, $T_0 = 1800^\circ\text{C}$, $\alpha = -5 \cdot 10^{-4}^\circ\text{C}^{-1}$, $V = 110\text{ V}$ and $P = 40.0\text{ W}$ gives

$$R_0 = \frac{(110\text{ V})^2}{40\text{ W}} \left(1 - (5.0 \cdot 10^{-4}^\circ\text{C}^{-1})(1800^\circ\text{C} - 20^\circ\text{C}) \right)^{-1} = 2750\ \Omega.$$

ROUND: Rounding to two significant figures yields $R_0 = 2800\ \Omega = 2.8\text{ k}\Omega$.

DOUBLE-CHECK: Ohms are appropriate units for resistance. The calculation can be checked by rounding the values to the nearest power of 10. $T \approx 0^\circ\text{C}$, $T_0 \approx 1000^\circ\text{C}$, $\alpha \approx -10^{-3}^\circ\text{C}^{-1}$, $V \approx 100\text{ V}$, and $P \approx 100\text{ W}$ (note that P was rounded to 100 since $\log 40 > 1.5$). Then,

$R_0 = (100\text{ V} / 100\text{ W}) \left[1 - (10^{-3}^\circ\text{C}^{-1})(1000^\circ\text{C} - 0^\circ\text{C}) \right] \approx 1000\ \Omega$. The approximated value is the same order of magnitude as the calculated value. This lends support to the calculation.

25.83. THINK: The energy dissipated in a resistor is equal to the energy required to move electrons along the direction of a current. The material may or may not be ohmic. The rate of energy dissipation in a resistor is equal to the amount of power required to push electrons.

SKETCH:

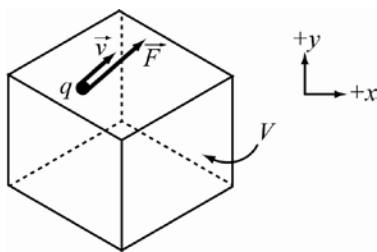

RESEARCH: If the force on the electrons is \vec{F} and the average velocity of the electrons is \vec{v} , the required power is $P = Fv$. Since $F = qE$, the power becomes $P = qEv$.

SIMPLIFY: Using the charge $q = neV$, where V is a small finite volume, the required power is $P = nevVE$ or $P = EJV$.

(a) Therefore, the power dissipated per unit volume is $P/V = EJ$.

(b) For an ohmic material the current density \vec{J} is related to \vec{E} by $\vec{J} = \sigma\vec{E}$. This equation yields the power dissipated per unit volume of $P/V = E(\sigma E) = \sigma E^2$ or $P/V = (J)(J)/\sigma = (1/\sigma)J^2 = \rho J^2$.

CALCULATE: Not required.

ROUND: Not required.

DOUBLE-CHECK: Examine the two sides of the equation $P/V = EJ$. The units of P/V are watts per cubic meter. The units of the product EJ are $(\text{V/m})(\text{A/m}^2) = \text{V A/m}^3 = \text{W/m}^3$. In (b), the units of P/V are still watts per cubic meter. Since $\vec{J} = \sigma\vec{E}$, the units of σ are A^2/mW . Therefore, the units of $(1/\sigma)J^2 = \rho J^2$ are $(\text{m W/A}^2)(\text{A/m}^2)^2 = (\text{m W/A}^2)(\text{A}^2/\text{m}^4) = \text{W/m}^3$. Thus, by dimensional analysis, the computed equations are sensible.

Multi-Version Exercises

Exercises 25.84–25.86 Following Solved Problem 25.4, we find $f = \frac{4P\rho_{\text{Cu}}L}{\pi(\Delta V)^2 d^2}$.

$$25.84. \quad f = \frac{4P\rho_{\text{Cu}}L}{\pi(\Delta V)^2 d^2} = \frac{4(7935 \cdot 10^6 \text{ W})(1.72 \cdot 10^{-8} \Omega\text{m})(643.1 \cdot 10^3 \text{ m})}{\pi(1.177 \cdot 10^6 \text{ V})^2 (0.02353 \text{ m})^2} = 0.1457 = 14.6\%.$$

$$25.85. \quad f = \frac{4P\rho_{\text{Cu}}L}{\pi(\Delta V)^2 d^2}$$

$$\Delta V = \sqrt{\frac{4P\rho_{\text{Cu}}L}{\pi f d^2}} = \sqrt{\frac{4(5319 \cdot 10^6 \text{ W})(1.72 \cdot 10^{-8} \Omega\text{m})(411.7 \cdot 10^3 \text{ m})}{\pi(0.07538)(0.02125 \text{ m})^2}} = 1.187 \cdot 10^6 \text{ V} = 1.19 \text{ MV}.$$

$$25.86. \quad f = \frac{4P\rho_{\text{Cu}}L}{\pi(\Delta V)^2 d^2}$$

$$L = \frac{\pi f (\Delta V)^2 d^2}{4P\rho_{\text{Cu}}} = \frac{\pi(0.1166)(1.197 \cdot 10^6 \text{ V})^2 (0.01895 \text{ m})^2}{4(5703 \cdot 10^6 \text{ W})(1.72 \cdot 10^{-8} \Omega\text{m})} = 4.804 \cdot 10^5 \text{ m} = 480. \text{ km}.$$

Exercises 25.87–25.88 The energy stored in the battery is equal to the power output of the battery multiplied by the time the battery delivers that power. The power delivered by the battery is $P = i\Delta V$. The energy stored in the battery is then $U = Pt = i\Delta Vt$.

$$25.87. \quad \text{The time is } t = 110.0 \text{ min} \frac{60 \text{ s}}{\text{min}} = 6600 \text{ s}.$$

$$U = i\Delta Vt = (25.0 \text{ A})(10.5 \text{ V})(6600 \text{ s}) = 1732500 \text{ J} = 1.73 \text{ MJ}.$$

$$25.88. \quad U = i\Delta Vt$$

$$t = \frac{U}{i\Delta V} = \frac{1.843 \cdot 10^6 \text{ J}}{(25.0 \text{ A})(10.5 \text{ V})} = 7020 \text{ s} = 117 \text{ min}$$

$$RC = 117$$

Exercises 25.89–25.91 The temperature dependence of resistance is $R - R_0 = R_0\alpha(T - T_0)$. The resistance at operating temperature is given by $\Delta V = iR \Rightarrow R = \frac{\Delta V}{i}$. Combining these equations gives us

$$\frac{\Delta V}{i} - R_0 = R_0\alpha(T - T_0)$$

$$T = T_0 + \frac{\frac{\Delta V}{i} - R_0}{R_0\alpha}.$$

$$25.89. \quad T = 20.00 \text{ }^\circ\text{C} + \frac{\frac{3.907 \text{ V}}{0.3743 \text{ A}} - 1.347 \Omega}{(1.347 \Omega)(4.5 \cdot 10^{-3} \text{ }^\circ\text{C}^{-1})} = 1520 \text{ }^\circ\text{C}$$

$$\begin{aligned}
 \mathbf{25.90.} \quad & \frac{\Delta V}{i} - R_0 = R_0 \alpha (T - T_0) \\
 & \frac{\Delta V}{i} = R_0 + R_0 \alpha (T - T_0) \\
 R_0 = & \frac{\Delta V / i}{1 + \alpha (T - T_0)} = \frac{\Delta V}{i [1 + \alpha (T - T_0)]} = \frac{3.949 \text{ V}}{(0.4201 \text{ A}) [1 + (4.5 \cdot 10^{-3} \text{ } ^\circ\text{C}^{-1})(1291 \text{ } ^\circ\text{C} - 20.00 \text{ } ^\circ\text{C})]} = 1.399 \text{ } \Omega
 \end{aligned}$$

$$\begin{aligned}
 \mathbf{25.91.} \quad & \frac{\Delta V}{i} - R_0 = R_0 \alpha (T - T_0) \\
 & \frac{\Delta V}{i} = R_0 + R_0 \alpha (T - T_0) \\
 i = & \frac{\Delta V}{R_0 [1 + \alpha (T - T_0)]} = \frac{3.991 \text{ V}}{(1.451 \text{ } \Omega) [1 + (4.5 \cdot 10^{-3} \text{ } ^\circ\text{C}^{-1})(1.110 \cdot 10^3 \text{ } ^\circ\text{C} - 20.00 \text{ } ^\circ\text{C})]} = 0.4658 \text{ A} = 465.8 \text{ mA}
 \end{aligned}$$

Chapter 26: Direct Current Circuits

Concept Checks

26.1. b 26.2. c 26.3. c 26.4. e 26.5. d 26.6. b 26.7. d

Multiple-Choice Questions

26.1. a 26.2. b 26.3. b 26.4. d 26.5. a 26.6. d 26.7. c 26.8. b 26.9. d, e & f 26.10. c 26.11. e 26.12. e 26.13. c

Conceptual Questions

26.14. In the first diagram, the voltmeter does not measure the voltage across the load resistor R_{Load} , but it measures the voltage across the series $R_{\text{Load}} + R_{\text{Ammeter}}$. As long as the internal resistance of the Ammeter is much less than R_{Load} , the effect can be neglected. Similarly, the Ammeter does not measure only the current through the load resistor R_{Load} , but also the current through the R_{Ammeter} . This means that the current measurement is affected by the value of R_{Ammeter} . As long as R_{Ammeter} is much less than R_{Load} the effect can be neglected.

In the second diagram, the voltmeter measures the voltage across the load resistor. However, the current flowing through R_{Load} is affected by the internal resistance of the voltmeter. As a result the measured voltage is altered from the original value. As long as the load resistance of the voltmeter $R_{\text{Voltmeter}}$ is much larger than the load resistance R_{Load} , the effect can be neglected. The ammeter measures the net current flowing through the resistors R_{Ammeter} , R_{Load} and $R_{\text{Voltmeter}}$. The effects of the internal resistors of the ammeter and the voltmeter are negligible if $R_{\text{Load}} \ll R_{\text{Voltmeter}}$ and $R_{\text{Ammeter}} \ll R_{\text{Load}}$.

26.15. The capacitive time constant is given by $\tau_0 = RC$. Since the equivalent of two identical capacitors connected in series is $C_{\text{eq}} = \left(\frac{1}{C} + \frac{1}{C}\right)^{-1} = \frac{1}{2}C$, the time constant is $\tau = RC_{\text{eq}} = (1/2)RC = (1/2)\tau_0$. Therefore, the time constant decreases by a factor of 2.

26.16. The resistance in the two-point probe measurement is given by the resistance of the device and the wires since they are in series. The four-point measurement is designed such that the resistance of the wires is no longer a part of the measurement so the real potential drop measured is that of the device. The four-point measurement, therefore, gives a better measurement of the real resistance.

26.17. For a capacitor, the rate of which it discharges is based on the current. If the resistance is high and the current is low then the discharge rate is slower. If the capacitance is large, then for a given voltage the amount of charge is higher, because $C = \frac{q}{\Delta V}$, and it will take a longer time for the capacitor to discharge. Hence, increasing R or C can increase the time constant.

26.18. The charge builds up on the capacitor. Thus, the emf of the capacitor balances the emf of the batteries. Summing around the circuit balances the emf, which must be zero regardless of the resistor. The current that satisfies this condition is zero.

26.19. An appropriate resistor R may be connected in series with the bulb and the battery, the value of the resistor can be solved by applying Kirchoff's loop rule for the circuit containing \mathcal{E} (the voltage of the car battery), R and the bulb. $\mathcal{E} - iR - iR_{\text{bulb}} = 0 \Rightarrow R = \mathcal{E}/i - R_{\text{bulb}}$ where $i = P/V$ and $R_{\text{bulb}} = V^2/P$.

Therefore,

$$R = \frac{\varepsilon V}{P} - \frac{V^2}{P} = \frac{V}{P}(\varepsilon - V) = \frac{1.5 \text{ V}}{1.0 \text{ W}}(12.0 \text{ V} - 1.5 \text{ V}) = 16 \Omega.$$

- 26.20.** If the emf's are doubled then the currents will also double as Kirchoff's junction rule will still be satisfied as long as all the currents are doubled. Kirchoff's Loop rule implies that if the potential drop across all the resistors is equal to the emf, then doubling the emf means that the currents must also double to account for the needed increases in the potential drop.
- 26.21.** With the capacitors uncharged at $t = 0$, the potential difference across each capacitor at that instant is zero, just like the potential difference of a connecting wire. After a long time, the capacitors will be fully charged, and the potential across the two points will be such that the charge cannot flow between the two points across the capacitor. This has the same effect as open segments in the circuit.
- 26.22.** When using a voltmeter, I want to measure the potential difference across a device. To do this, I set it up parallel to the component, because the potential drop is the same for any two circuit elements in parallel. Ammeters are instruments with very low resistance designed to measure the current. Think of this as a device submerged into a running stream. In order for the instrument to measure the flow, it has to be "in the stream". Similarly, ammeters are in series with the components they wish to measure.
- 26.23.** This question provides an example of meter loading. In connecting an ordinary voltmeter and ammeter simultaneously to some component of a circuit, only two possible orientations are available: one can connect the ammeter in series with the parallel combination of the voltmeter and the component, or one can connect the voltmeter in parallel with the series combination of the ammeter and the component. In the first case, the ammeter measures not the current through the component but the current through the component and the voltmeter, which is slightly greater for any voltmeter with non-infinite resistance. In the second case, the voltmeter measures not the potential difference across the component, but the potential difference across the component and the ammeter, which will be slightly greater for any ammeter with non zero resistance. Simultaneous exact measurements of the current and voltage for the components alone are not possible with ordinary meters. The restriction "with ordinary meters" is reiterated here because it is possible to measure the voltage across a component, for example, without drawing current. This can be done via a "null measurement" such as is done with a potentiometer.
- 26.24.** $P = V^2/R$ implies $R = V^2/P$. A larger power rating implies a smaller filament resistance. Therefore, the answer is a 100 W bulb.

- 26.25.** Since the constant is given by RC , the ratio of the times is equal to the ratio of the capacitances. The capacitances in each case are: series: $C_{\text{series}} = C_1 C_2 / (C_1 + C_2)$, parallel: $C_{\text{parallel}} = C_1 + C_2$. The ratio is then:

$$\frac{C_{\text{parallel}}}{C_{\text{series}}} = \frac{C_1 + C_2}{\left(\frac{C_1 C_2}{C_1 + C_2}\right)} = \frac{(C_1 + C_2)^2}{C_1 C_2} = \frac{C_1^2 + 2C_1 C_2 + C_2^2}{C_1 C_2} = \frac{C_1}{C_2} + \frac{C_2}{C_1} + 2.$$

The time to charge the capacitors in parallel is larger by a factor of $\frac{C_1}{C_2} + \frac{C_2}{C_1} + 2$ (which is at least 2).

- 26.26.** (a) The current at any time t is given by: $i = i_{\text{initial}} e^{-t/\tau}$ where $i_{\text{initial}} = V/R$ and $\tau = RC$.
 (b) The power of the battery is $P = Vi$. Integrated over all time, the power gives us the energy

$$\int_0^{\infty} P dt = \int_0^{\infty} Vi dt = \int_0^{\infty} (V^2/R) e^{-t/(RC)} dt = CV^2.$$

(c) The power dissipation from R is $P = iR$. $\int_0^{\infty} iR dt = \int_0^{\infty} (V^2/R) e^{-2t/(RC)} dt = (1/2)CV^2$.

(d) Note that the energy provided by the battery less the energy dissipated by the resistor is the energy stored in the capacitor satisfying the law of conservation of energy.

Exercises

- 26.27. The total resistance of the circuit is given by: $R_{\text{total}} = R_1 + R_2$. The current is then $I = \Delta V / R_{\text{total}}$. The potential drop across each resistor is then:

$$V_1 = \left(\frac{R_1}{R_1 + R_2} \right) \Delta V, \quad V_2 = \left(\frac{R_2}{R_1 + R_2} \right) \Delta V.$$

The resistors in series construct a voltage divider. The voltage ΔV is divided between the two resistors with potential drop proportional to their respective resistances.

- 26.28. The current must be such that $P = I^2 R = 10.0 \text{ W}$.

$$\begin{aligned} I = \frac{V_{\text{emf}}}{r + R} &\Rightarrow \left(\frac{V_{\text{emf}}}{r + R} \right)^2 R = P \Rightarrow (V_{\text{emf}})^2 R = r^2 P + 2rRP + R^2 P \\ &\Rightarrow 12.0^2 R = 1.0^2 (10.0) + 2(1.00)(10.0)R + 10.0R^2 \Rightarrow 0 = R^2 - 12.4R + 1.00. \end{aligned}$$

Solving this quadratic equation yields: $R = \frac{12.4 \pm \sqrt{12.4^2 - 4.00}}{2.00} \Omega = 0.0812 \Omega$ or 12.3Ω . Either of those two resistances will work.

- 26.29. Kirchhoff's Loop Rule around the upper loop and large loop yields

$$V_{\text{emf}} - (2.00 \text{ A})R - (2.00 \text{ A})(20.0 \Omega) = 0 \quad \text{and} \quad V_{\text{emf}} - (3.00 \text{ A})R = 0 \Rightarrow V_{\text{emf}} = (3.00 \text{ A})R,$$

respectively. Therefore,

$$(3.00 \text{ A})R - (2.00 \text{ A})R - (2.00 \text{ A})(20.0 \Omega) = 0 \Rightarrow (1.00 \text{ A})R = (2.00 \text{ A})(20.0 \Omega) \Rightarrow R = 40.0 \Omega$$

$$V_{\text{emf}} = (3.00 \text{ A})(40.0 \Omega) = 120. \text{ V}.$$

- 26.30. **THINK:** Close inspection of the diagram shows that there is no current flowing across the middle resistor is zero. This is because there is nothing different between the point above and below the middle resistor. That resistor can therefore be removed while changing nothing.

SKETCH: The new diagram is then:

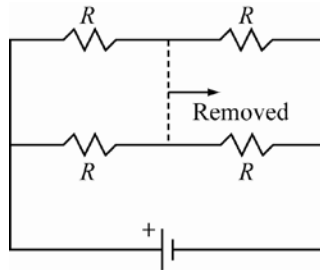

RESEARCH: The equivalent resistances of the top two resistors and the bottom two resistors are given by $R_{\text{top}} = R + R = 2R$, and $R_{\text{bottom}} = R + R = 2R$, respectively. The system's total equivalent resistance is given

$$\text{by } R_{\text{eq}} = \left(\frac{1}{2R} + \frac{1}{2R} \right)^{-1}.$$

$$\text{SIMPLIFY: } R_{\text{eq}} = \left(\frac{1}{2R} + \frac{1}{2R} \right)^{-1} = \left(\frac{2}{2R} \right)^{-1} = R$$

CALCULATE: Not required.

ROUND: Not required.

DOUBLE-CHECK: The total resistance is comparable to each of the individual resistors as one would expect.

26.31. THINK:

(a) The dead battery is parallel to the starter and the live battery.

(b) Kirchoff's Laws can be used to find the currents. Use the data:

$$V_L = 12.00 \text{ V}, V_D = 9.950 \text{ V}, R_L = 0.0100 \ \Omega, R_D = 1.100 \ \Omega, R_S = 0.0700 \ \Omega.$$

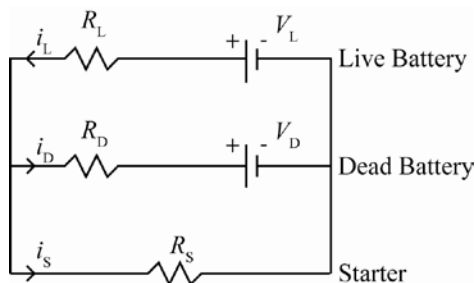
SKETCH:

RESEARCH: Kirchoff's Laws give:

$$i_L = i_D + i_S \quad (1)$$

$$i_D = i_L - i_S \quad (1.1)$$

$$V_L - i_L R_L - i_S R_S = 0 \quad (2)$$

$$V_D + i_D R_D - i_S R_S = 0 \quad (3)$$

SIMPLIFY: Substitute (1) into (2) and solve for i_D . $V_L - (i_D + i_S)R_L - i_S R_S = 0$ implies

 $V_L - i_D R_L - i_S (R_L + R_S) = 0$, which in turn implies

$$i_D = \frac{V_L - i_S (R_L + R_S)}{R_L} \quad (4)$$

 Substitute (4) into (3) and solve for i_S . $V_D + \left(\frac{V_L - i_S (R_L + R_S)}{R_L} \right) R_D - i_S R_S = 0$ implies

$$i_S = \frac{V_D R_L + V_L R_D}{R_L R_D + R_S R_D + R_S R_L} \quad (5)$$

 Substitute (1.1) into (3) and solve for i_S . $V_D + (i_L - i_S)R_D - i_S R_S = 0$ implies

$$i_S = \frac{V_D + i_L R_D}{R_D + R_S} \quad (6)$$

 Substitute (6) into (2) and solve for i_L . $V_L - i_L R_L - \left(\frac{V_D + i_L R_D}{R_D + R_S} \right) R_S = 0$ implies

$$i_L = \frac{V_L R_D + V_L R_S - V_D R_S}{R_L R_D + R_L R_S + R_D R_S} \quad (7)$$

 Substitute (5) and (7) into (1) and solve for i_L .

$$\text{CALCULATE: } i_S = \frac{(9.950 \text{ V})(0.0100 \ \Omega) + (12.00 \text{ V})(1.100 \ \Omega)}{(0.0100 \ \Omega)(1.100 \ \Omega) + (0.0700 \ \Omega)(1.100 \ \Omega) + (0.0700 \ \Omega)(0.0100 \ \Omega)} = 149.938 \text{ A}$$

$$i_L = \frac{(12.00 \text{ V})(1.100 \ \Omega) + (12.00 \text{ V})(0.0700 \ \Omega) - (9.950 \text{ V})(0.0700 \ \Omega)}{(0.0100 \ \Omega)(1.100 \ \Omega) + (0.0100 \ \Omega)(0.0700 \ \Omega) + (1.100 \ \Omega)(0.0700 \ \Omega)} = 150.434 \text{ A}$$

$$150.434 \text{ A} = i_D + 149.938 \text{ A} \Rightarrow i_D = 150.434 \text{ A} - 149.938 \text{ A} = 0.496 \text{ A}$$

ROUND: Three significant figures: $i_S = 150. \text{ A}$, $i_L = 150. \text{ A}$, $i_D = 0.496 \text{ A}$.

DOUBLE-CHECK: Inserting the calculated values back into the original Kirchoff's equations;

$$V_L - i_L R_L - i_S R_S = (12 \text{ V}) - (150 \text{ A})(0.01 \ \Omega) - (150 \text{ A})(0.07 \ \Omega) = 0,$$

and

$$V_D + i_D R_D - i_S R_S = (9.95 \text{ V}) + (0.496 \text{ A})(1.1 \Omega) - (150 \text{ A})(0.07 \Omega) = 0,$$

as required.

- 26.32. THINK:** There is only one unknown, so one equation is sufficient to solve the problem. Use Kirchoff's Loop Law to obtain the answer.

SKETCH:

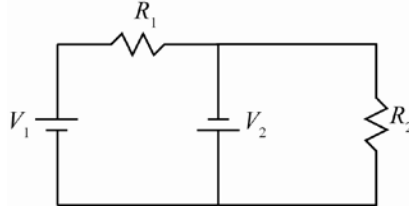

RESEARCH: Kirchoff's Loop Law gives $V_1 - i_1 R_1 + V_2 = 0$ for the first loop.

SIMPLIFY: $i_1 = \frac{V_2 + V_1}{R_1}$

CALCULATE: $i_1 = \frac{2.5 \text{ V} + 1.5 \text{ V}}{4.0 \Omega} = 1.0 \text{ A}$

ROUND: $i_1 = 1.0 \text{ A}$

DOUBLE-CHECK: Consider the outside loop: $V_1 - i_1 R_1 - i_2 R_2 = 0$. From the second loop, $-V_2 - i_2 R_2 = 0 \Rightarrow i_2 = V_2 / R_2$. So, $0 = V_1 - i_1 R_1 - i_2 R_2 = V_1 - i_1 R_1 - (V_2 / R_2) R_2 \Rightarrow i_1 = 1.0 \text{ A}$, as before.

- 26.33. THINK:** Kirchoff's Laws can be used to determine the currents. Use the values: $V_A = 6.0 \text{ V}$, $V_B = 12.0 \text{ V}$, $R_1 = 10.0 \Omega$, $R_2 = 40.0 \Omega$, and $R_3 = 10.0 \Omega$.

SKETCH:

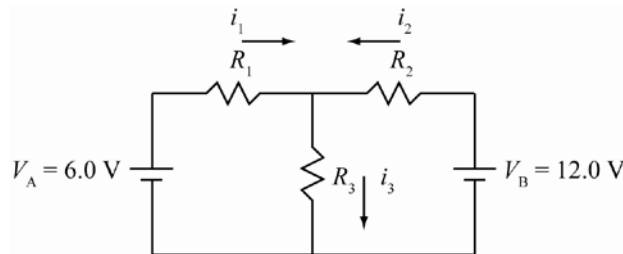

RESEARCH: $i_3 = i_1 + i_2$, $V_A = i_1 R_1 + i_3 R_3$, $V_B = i_2 R_2 + i_3 R_3$, $V_A - i_1 R_1 + i_2 R_2 - V_B = 0$, and $P = iV$.

SIMPLIFY: $V_A = i_1 R_1 + (i_1 + i_2) R_3 \Rightarrow i_1 = \frac{V_A - i_2 R_3}{R_1 + R_3}$

$$V_B = i_2 R_2 + (i_1 + i_2) R_3 \Rightarrow V_B = i_2 R_2 + \left[\frac{V_A - i_2 R_3}{R_1 + R_3} + i_2 \right] R_3 \Rightarrow V_B = i_2 R_2 + \frac{V_A R_3}{R_1 + R_3} - \frac{i_2 R_3^2}{R_1 + R_3} + i_2 R_3$$

$$i_2 = \frac{\left(V_B - \frac{V_A R_3}{R_1 + R_3} \right)}{\left(R_2 - \frac{R_3^2}{R_1 + R_3} + R_3 \right)}, \quad i_1 = \frac{V_A - i_2 R_3}{R_1 + R_3}, \quad i_3 = i_1 + i_2$$

$P_A = i_1 V_A$, $P_B = i_2 V_B$

CALCULATE: $i_2 = \left(12.0 \text{ V} - \frac{(6.0 \text{ V})(10.0 \Omega)}{10.0 \Omega + 10.0 \Omega} \right) / \left(40.0 \Omega - \frac{(10.0 \Omega)^2}{10.0 \Omega + 10.0 \Omega} + 10.0 \Omega \right) = 0.20 \text{ A}$

$$i_1 = \frac{6.0 \text{ V} - (0.20 \text{ A})(10.0 \Omega)}{10.0 \Omega + 10.0 \Omega} = 0.20 \text{ A}, \quad i_3 = 0.20 \text{ A} + 0.20 \text{ A} = 0.40 \text{ A}$$

$$P_A = (0.20 \text{ A})(6.0 \text{ V}) = 1.2 \text{ W}, \quad P_B = (0.20 \text{ A})(12.0 \text{ V}) = 2.4 \text{ W}$$

ROUND: $i_1 = 0.20 \text{ A}$, $i_2 = 0.20 \text{ A}$, $i_3 = 0.40 \text{ A}$, $P_A = 1.2 \text{ W}$, and $P_B = 2.4 \text{ W}$.

DOUBLE-CHECK: The direction of i_1 and i_2 makes sense since they are in the direction of the driving force of the battery.

- 26.34. THINK:** The circuit has three branches. Kirchoff's Loop and junction laws can be used to find at least three linearly independent equations. Use the values: $R_1 = 5.00 \Omega$, $R_2 = 10.0 \Omega$, $R_3 = 15.0 \Omega$, $V_{\text{emf},1} = 10.0 \text{ V}$, and $V_{\text{emf},2} = 15.0 \text{ V}$.

SKETCH:

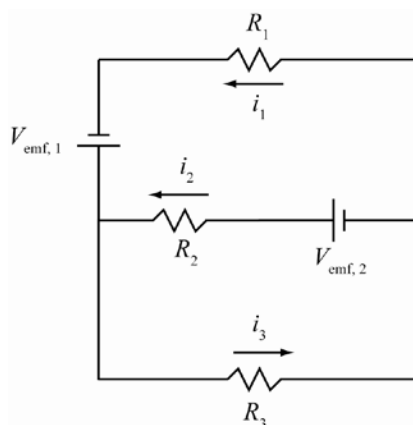

RESEARCH:

$$V_{\text{emf},1} - V_{\text{emf},2} + i_2 R_2 - i_1 R_1 = 0 \quad (1)$$

$$V_{\text{emf},1} - i_3 R_3 - i_1 R_1 = 0 \quad (2)$$

$$i_1 + i_2 = i_3 \quad (3)$$

SIMPLIFY: Substitute (3) into (2) and solve for i_1 : $V_{\text{emf},1} - (i_1 + i_2)R_3 - i_1 R_1 = 0$ implies

$$i_1 = \frac{V_{\text{emf},1} - i_2 R_3}{R_1 + R_3} \quad (4)$$

Substitute 4 into 1 and solve for i_2 :

$$V_{\text{emf},1} - V_{\text{emf},2} + i_2 R_2 - \left(\frac{V_{\text{emf},1} - i_2 R_3}{R_1 + R_3} \right) R_1 = 0 \Rightarrow i_2 = \frac{V_{\text{emf},2} - V_{\text{emf},1} + (V_{\text{emf},1} R_1 / (R_1 + R_3))}{(R_1 R_3 / (R_1 + R_3)) + R_2} \quad (5)$$

CALCULATE: $i_2 = \frac{15.0 \text{ V} - 10.0 \text{ V} + (10.0 \text{ V})(5.00 \Omega) / (5.00 \Omega + 15.0 \Omega)}{(5.00 \Omega)(15.0 \Omega) / (5.00 \Omega + 15.0 \Omega) + 10.0 \Omega} = 0.54545 \text{ A}$

$$i_1 = \frac{10.0 \text{ V} - i_2 (15.0 \Omega)}{5.00 \Omega + 15.0 \Omega} = 0.09091 \text{ A}$$

$$i_3 = i_1 + i_2 = 0.636363 \text{ A}$$

ROUND: To three significant figures: $i_1 = 0.0909 \text{ A}$, $i_2 = 0.545 \text{ A}$, $i_3 = 0.636 \text{ A}$

DOUBLE-CHECK: The calculated values for the currents are all positive, which is consistent with the direction specified in the problem.

26.35. **THINK:** Kirchhoff's Laws can be applied to this circuit. We must identify the junctions and the loops. We note that the currents through resistors 1 and 3 are the same and the currents through resistors 6 and 7 are the same. We have five unknowns, i_1 , i_2 , i_4 , i_5 , and i_6 . We need five equations for the solution.

SKETCH:

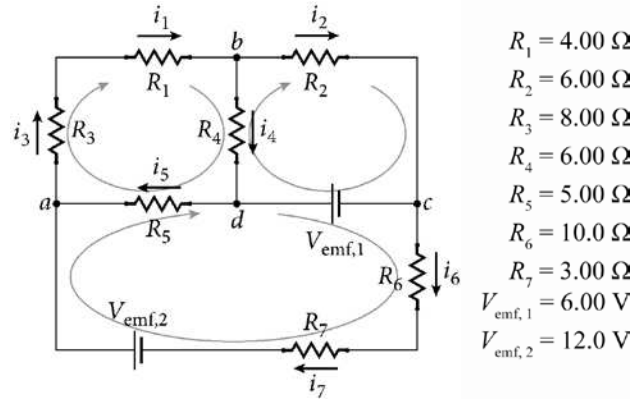

RESEARCH: We have $i_1 = i_3$ and $i_6 = i_7$. We take the directions of the currents as shown in the sketch. There are four junctions giving the following equations

$$a: i_5 + i_6 = i_1$$

$$b: i_1 = i_2 + i_4.$$

There are three loops that can be analyzed using Kirchhoff's loop rule. Analyzing each loop in the clockwise direction:

$$\text{Starting at } a: -i_1 R_3 - i_1 R_1 - i_4 R_4 - i_5 R_5 = 0$$

$$\text{Starting at } d: -V_{\text{emf},1} - i_6 R_6 - i_6 R_7 + V_{\text{emf},2} + i_5 R_5 = 0$$

$$\text{Starting at } c: V_{\text{emf},1} + i_4 R_4 - i_2 R_2 = 0.$$

The power supplied by each battery is given by $P = Vi$.

SIMPLIFY: Cramer's rule is the most efficient method for solving a system of five equations and five unknowns. Rearranging the equations:

$$-i_1 + i_5 + i_6 = 0$$

$$i_1 - i_2 - i_4 = 0$$

$$-i_1(R_1 + R_3) - i_4 R_4 - i_5 R_5 = 0$$

$$i_5 R_5 - i_6(R_6 + R_7) = V_{\text{emf},1} - V_{\text{emf},2}$$

$$-i_2 R_2 + i_4 R_4 = -V_{\text{emf},1}.$$

Taking the coefficients of the currents, we can write the matrix equation as:

$$\begin{bmatrix} -1 & 0 & 0 & 1 & 1 \\ 1 & -1 & -1 & 0 & 0 \\ -(R_1 + R_3) & 0 & -R_4 & -R_5 & 0 \\ 0 & 0 & 0 & R_5 & -(R_6 + R_7) \\ 0 & -R_2 & R_4 & 0 & 0 \end{bmatrix} \begin{bmatrix} i_1 \\ i_2 \\ i_4 \\ i_5 \\ i_6 \end{bmatrix} = \begin{bmatrix} 0 \\ 0 \\ 0 \\ V_{\text{emf},1} - V_{\text{emf},2} \\ -V_{\text{emf},1} \end{bmatrix}$$

CALCULATE: We can use Cramer's rule to solve this system of five equations and five unknowns

$$\begin{bmatrix} -1 & 0 & 0 & 1 & 1 \\ 1 & -1 & -1 & 0 & 0 \\ -12.00 & 0 & -6.00 & -5.00 & 0 \\ 0 & 0 & 0 & 5.00 & -13.00 \\ 0 & -6.00 & 6.00 & 0 & 0 \end{bmatrix} \begin{bmatrix} i_1 \\ i_2 \\ i_4 \\ i_5 \\ i_6 \end{bmatrix} = \begin{bmatrix} 0 \\ 0 \\ 0 \\ -6.00 \\ -6.00 \end{bmatrix}$$

The solution can be calculated by hand using Cramer's rule or using a computer algebra system. The matrix, when evaluated by such a program into reduced row echelon form, gives the numeric solution as:

$$\begin{bmatrix} 1 & 0 & 0 & 0 & 0 \\ 0 & 1 & 0 & 0 & 0 \\ 0 & 0 & 1 & 0 & 0 \\ 0 & 0 & 0 & 1 & 0 \\ 0 & 0 & 0 & 0 & 1 \end{bmatrix} \begin{bmatrix} i_1 \\ i_2 \\ i_4 \\ i_5 \\ i_6 \end{bmatrix} = \begin{bmatrix} 0.250746 \\ 0.625373 \\ -0.374627 \\ -0.152239 \\ 0.402985 \end{bmatrix} \Rightarrow \begin{matrix} i_1 = 0.250746 \text{ A} \\ i_2 = 0.625373 \text{ A} \\ i_4 = -0.374627 \text{ A} \\ i_5 = -0.152239 \text{ A} \\ i_6 = 0.402985 \text{ A} \end{matrix}$$

The current through resistors R_1 and R_3 is $i_1 = i_3 = 0.250746 \text{ A}$ in the assumed direction. The current through resistor R_2 is $i_2 = 0.625373 \text{ A}$ in the assumed direction. The current through resistor R_4 is $i_4 = 0.374627 \text{ A}$ in a direction opposite to the assumed direction. The current through resistor R_5 is $i_5 = 0.152239 \text{ A}$ in a direction opposite to the assumed direction. The current through resistors R_6 and R_7 is $i_6 = i_7 = 0.402985 \text{ A}$ in the assumed direction.

The current flowing through $V_{\text{emf},1}$ is given by

$$i_2 + i_4 = 0.625373 \text{ A} - 0.374627 \text{ A} = 0.250746 \text{ A}.$$

$$P(V_{\text{emf},1}) = (6.00 \text{ V})(0.250746 \text{ A}) = 1.504476 \text{ W}.$$

The current flowing through $V_{\text{emf},2}$ is given by

$$i_1 + i_2 + i_3 + i_6 + i_7 = 0.250746 \text{ A} + 0.625373 \text{ A} + 0.250746 \text{ A} + 0.402985 \text{ A} + 0.402985 \text{ A} = 1.932835 \text{ A}.$$

$$P(V_{\text{emf},2}) = (12.0 \text{ V})(1.932835 \text{ A}) = 23.19402 \text{ W}.$$

ROUND: Rounding to three significant digits and assigning the directions we have:

	Magnitude	Direction
i_1	0.251 A	to the right
i_2	0.625 A	to the right
i_3	0.251 A	upward
i_4	0.375 A	upward
i_5	0.152 A	to the right
i_6	0.403 A	downward
i_7	0.403 A	to the left

$$P(V_{\text{emf},1}) = 1.50 \text{ W}, \quad P(V_{\text{emf},2}) = 23.2 \text{ W}.$$

DOUBLE-CHECK: We can substitute out results for the five currents back into our five equations and show that they are satisfied.

- 26.36. THINK:** When the potential difference between a and b is zero, no current will flow. The potential difference will be zero when the ratio of the resistances above the ammeter is equal to the ratio of the resistances below the ammeter. Use $L_1 = 25.0 \text{ cm}$ and $L_2 = 75.0 \text{ cm}$.

SKETCH:

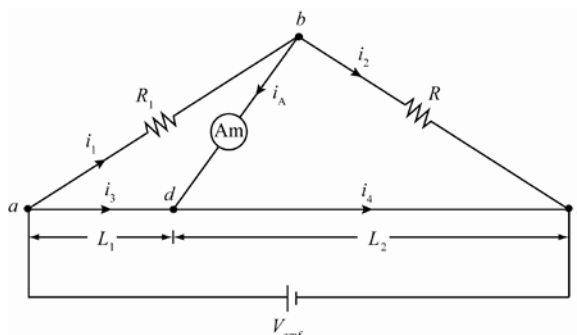

RESEARCH: The current is zero when $\frac{R_1}{R_x} = \frac{R_{L_1}}{R_{L_2}} \Rightarrow R_1 R_{L_2} = R_x R_{L_1}$, $R_1 = 100. \Omega$. $R_{L_1} = \rho \frac{L_1}{A}$ and $R_{L_2} = \rho \frac{L_2}{A}$.

SIMPLIFY: $R_1 \rho \left(\frac{L_2}{A} \right) = R_x \rho \left(\frac{L_1}{A} \right)$, $R_x = R_1 \frac{L_2}{L_1}$

CALCULATE: $R_x = (100. \Omega) \left(\frac{75.0 \text{ cm}}{25.0 \text{ cm}} \right) = 300. \Omega$

ROUND: $R_x = 300. \Omega$

DOUBLE-CHECK: R_x is comparable to R_1 as one would expect.

26.37. THINK: Suppose the total equivalent resistance of the ladder up to some arbitrary point is given by R_L . Since the ladder is infinite, it does not matter what point on the ladder is chosen for the analysis, and adding one more segment to the end will not change the equivalent resistance of the network.

SKETCH:

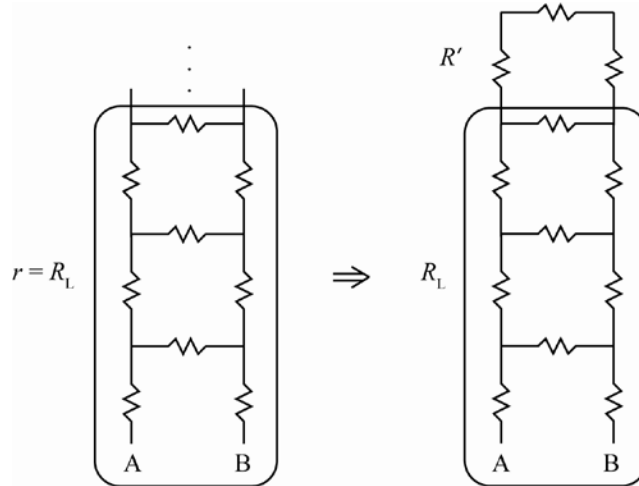

RESEARCH: The ladder consists of the array with resistance R_L plus another segment with resistance R' . R' contributes one resistor of resistance R , in parallel with the array, and two resistors of resistance, R , in series with the array. The total resistance is now $R'_L = 2R + R \parallel R_L = R_L$.

SIMPLIFY: $R_L = 2R + R \parallel R_L = 2R + \left(\frac{1}{R} + \frac{1}{R_L} \right)^{-1} = 2R + \frac{RR_L}{R + R_L}$

$R_L = 2R + \frac{RR_L}{R + R_L} \Rightarrow R_L (R + R_L) = 2R(R + R_L) + RR_L \Rightarrow R_L^2 - 2RR_L - 2R^2 = 0$

CALCULATE: Solving the quadratic equation for R_L gives $R_L = (1 + \sqrt{3})R$.

ROUND: Since no values are given in the question, it is best to leave the answer in its precise form, $R_L = (1 + \sqrt{3})R$.

DOUBLE-CHECK: Consider the first rung of three resistors in series. The equivalent resistance is $R_{eq} = 3R$. Now, add another rung of three resistors. One resistor is in parallel with the first rung, and two resistors are in series with the first rung. The equivalent resistance is now

$$R_{eq,1} = \left(\frac{1}{3R} + \frac{1}{R} \right)^{-1} + 2R = \frac{11}{4}R = 2.75R.$$

Adding another rung gives $R_{\text{eq},2} = \left(\frac{4}{11R} + \frac{1}{R} \right)^{-1} + 2R = \frac{41}{15}R = 2.7333R$. Repeating the process, $R_{\text{eq},3} = \frac{153}{56}R = 2.7324R$, $R_{\text{eq},4} = \frac{571}{209}R = 2.73206R$, ..., $R_n \rightarrow (1 + \sqrt{3})R$. This verifies the value found in the solution.

26.38. THINK: This is a very famous and very tricky problem. Superposition can be used to find the answer. I will inject 1 Amp into A as specified below and extract 1 Amp from B as specified below.

SKETCH:

1 Amp injected into A:

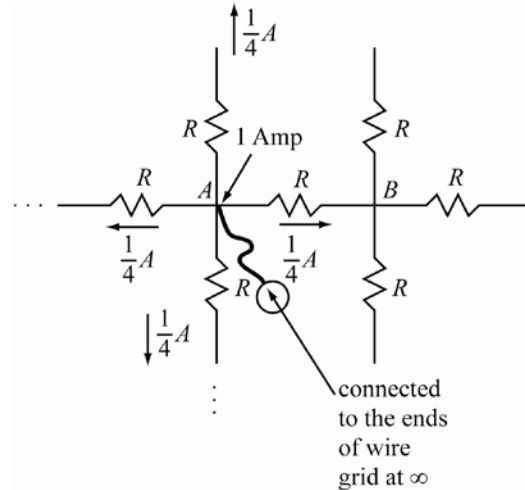

1 Amp extracted from B:

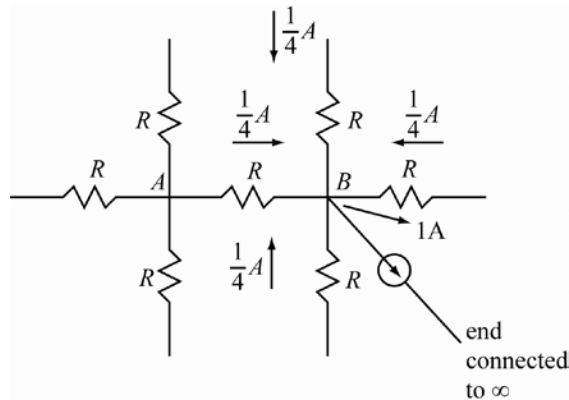

RESEARCH: The superposition of the two cases has 1 Amp entering A and leaving B. The superposition of the currents indicates that $(1/2)A$ passes through the resistor R_{AB} , showing the effective resistance between the two points is $R/2$.

SIMPLIFY: Not required.

CALCULATE: Not required.

ROUND: Not required.

DOUBLE-CHECK: It makes sense that the effective resistance is less than R since there are other pathways for the current to flow.

- 26.39. Let i_A be the maximum current (i.e. full scale value) the ammeter can measure without the shunt. If the shunt is to extend the full scale value by a factor $N = i_{\text{tot}} / i_A$, then

$$i_A + i_{\text{shunt}} = Ni_A \Rightarrow \frac{i_{\text{shunt}}}{i_A} = N - 1.$$

Since the ammeter and shunt have the same voltage across them,

$$R_{i,A} i_A = R_{\text{shunt}} i_{\text{shunt}} \Rightarrow R_{\text{shunt}} = \frac{i_A}{i_{\text{shunt}}} R_{i,A} = \frac{R_{i,A}}{N - 1}.$$

To allow a current of 100 A, the resistance of the shunt resistor must be

$$R_{\text{shunt}} = \frac{(1.00 \Omega)}{(100. \text{ A} / 1.00 \text{ A}) - 1} = \frac{1.00 \Omega}{99.0} = 10.1 \text{ m}\Omega.$$

The fraction of the total current flowing through the ammeter is

$$\frac{i_A}{i_{\text{tot}}} = \frac{(1.00 \text{ A})}{(100. \text{ A})} = 0.0100.$$

The fraction of the total current flowing through the shunt is

$$\frac{i_{\text{shunt}}}{i_{\text{tot}}} = 1 - \frac{(1.00 \text{ A})}{(100. \text{ A})} = 0.990.$$

- 26.40. The voltage across the device must be smaller than the voltage across the device and the resistor by a factor of N . $N(V_{1,V}) = V_{1,V} + V_{\text{series}}$. Since $i_{1,V} = i_{\text{series}}$:

$$\frac{V_{1,V}}{R_{1,V}} = \frac{V_{\text{series}}}{R_{\text{series}}} \Rightarrow N(V_{1,V}) = V_{1,V} + \left(\frac{R_{\text{series}}}{R_{1,V}} \right) V_{1,V} \Rightarrow N = 1 + \frac{R_{\text{series}}}{R_{1,V}} \Rightarrow R_{\text{series}} = (N - 1)R_{1,V}$$

Numerical Application: $R_{\text{series}} = (100. - 1)1.00 \cdot 10^6 \Omega = 99.0 \cdot 10^6 \Omega = 99.0 \text{ M}\Omega$. The 1.00 V potential drop across the voltmeter is 1.00% of the total power. The other 99.0 V potential drop occurs across the added series resistor and is 99.0% of the total.

- 26.41. The sketch illustrates the case of measuring V_{ab} .

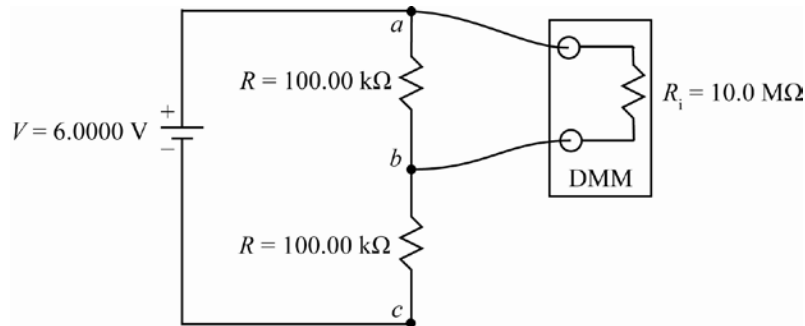

The total resistance is $\frac{RR_i}{R + R_i} + R$. The total current is

$$i = \frac{V}{\frac{RR_i}{R + R_i} + R} = \frac{6.0000 \text{ V}}{\frac{(1.0000 \cdot 10^5 \Omega)(1.00 \cdot 10^7 \Omega)}{1.0000 \cdot 10^5 \Omega + 1.00 \cdot 10^7 \Omega} + 1.0000 \cdot 10^5 \Omega} = 3.0149 \cdot 10^{-5} \text{ A}.$$

The potential across the voltmeter is

$$V_{ab} = i \frac{RR_1}{R + R_1} = (3.0149 \cdot 10^{-5} \text{ A}) \frac{(1.0000 \cdot 10^5 \Omega)(1.00 \cdot 10^7 \Omega)}{1.0000 \cdot 10^5 \Omega + 1.00 \cdot 10^7 \Omega} = 2.985 \text{ V} = 2.99 \text{ V},$$

Increasing R_1 will reduce the error since the voltmeter will draw less current.

26.42. (a) The current is to be 10.0 mA for a voltage of 9.00 V. $R = V_{\text{emf}} / i = 9.00 \text{ V} / (10.0 \text{ mA}) = 900. \Omega$

(b) The current is 2.50 mA. The resistance is $R_{\text{variable}} + R$. The current is given by

$$i = \frac{V_{\text{emf}}}{R_{\text{variable}} + R} \Rightarrow iR_{\text{variable}} + iR = V_{\text{emf}} \Rightarrow R = \frac{V_{\text{emf}} - iR_{\text{variable}}}{i} = \frac{9.00 \text{ V} - (2.50 \text{ mA})(900. \Omega)}{2.50 \text{ mA}} = 2.70 \text{ k}\Omega.$$

26.43. THINK:

(a) The total resistance must first be determined in order to find the current. Since the resistors are in series, the same current flows through both of them.

(b) The current that flows through the circuit is the result of the equivalent resistance including the ammeter. The same current flows through the 1.00 k Ω resistor and the parallel combination of resistor and ammeter. Of the current flowing through this combination, the majority will flow through the lower resistance, i.e., the ammeter. The fraction of the current that goes through the Ammeter can be calculated using the resistances.

SKETCH:

(a)

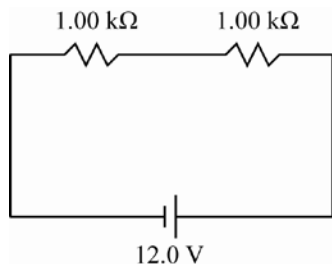

(b)

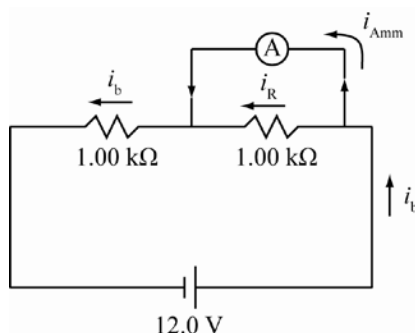

RESEARCH:

(a) $R_{\text{eq}} = 2R$, $R = 1.00 \text{ k}\Omega$, $i_a = V / R_{\text{eq}}$, $V = 12.0 \text{ V}$

(b) The current that flows through the circuit is $i_b = \frac{V}{R_{\text{eq}}}$, where $R_{\text{eq}} = R + \left(\frac{RR_A}{R + R_A} \right)$, $R_A = 1.0 \Omega$. The current flowing through the resistor/ammeter combination is split into two parts. $i_R = \Delta V_1 / R$, and $i_{\text{Amm}} = \Delta V_2 / R_A$.

SIMPLIFY:

(a) $i_a = \frac{V}{2R}$

(b) $i_{\text{Amm}} = \frac{\Delta V_2}{R_{\text{Amm}}} = \frac{i_b RR_{\text{Amm}}}{R_{\text{Amm}}(R + R_{\text{Amm}})} = \frac{V}{R + \left(\frac{RR_{\text{Amm}}}{R + R_{\text{Amm}}} \right)} \cdot \left(\frac{RR_{\text{Amm}}}{R_{\text{Amm}}(R + R_{\text{Amm}})} \right) = \frac{V}{R + 2R_{\text{Amm}}}$

CALCULATE:

(a) $i_a = \frac{12.0 \text{ V}}{2(1.00 \cdot 10^3 \Omega)} = 6.00 \text{ mA}$

$$(b) \frac{12.0 \text{ V}}{(1.00 \text{ k}\Omega + 2 \cdot (1.0 \text{ }\Omega))} = 0.01198 \text{ A}$$

ROUND:

$$(a) i_a = 6.00 \text{ mA}$$

$$(b) i_{\text{Amm}} = 0.012 \text{ A}$$

DOUBLE-CHECK: The ammeter measures the current across the other resistor acting like a short across the first resistor, as would be expected.

26.44. **THINK:**

(a) I need to find the total resistance and then find the potential drop in each resistor.

(b) When a voltmeter is connected across one of the resistors, the combination of the resistor and the voltmeter will have an equivalent resistance slightly different from that of the resistor alone. This will cause a change in the potential drop across the resistor/voltmeter combination. I need to calculate the new potential drop.

SKETCH:

(a)

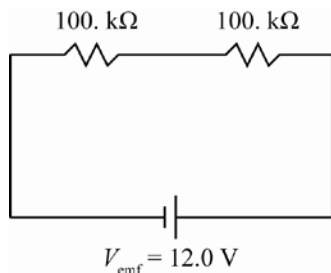

(b)

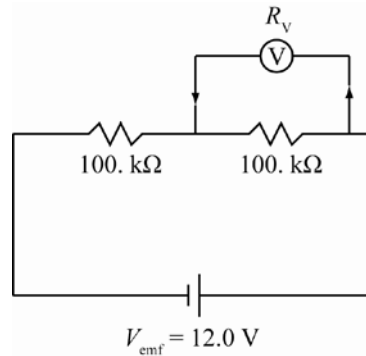

RESEARCH:

(a) Since they are identical and in series, the resistors have the same potential drop of $V/2$.

(b) The total resistance is now given by $R_{\text{total}} = R + \left(\frac{R_{\text{voltmeter}} R}{R_{\text{voltmeter}} + R} \right)$. The potential drop across the voltmeter

$$\text{is then } V_{\text{voltmeter}} = iR = \left(\frac{V}{R_{\text{total}}} \right) \left(\frac{R_{\text{voltmeter}} R}{R_{\text{voltmeter}} + R} \right).$$

SIMPLIFY: Not required.

CALCULATE:

$$(a) \frac{12.0 \text{ V}}{2} = 6.00 \text{ V}$$

$$(b) R_{\text{total}} = 100. \text{ k}\Omega + \frac{(10.0 \text{ M}\Omega)(100. \text{ k}\Omega)}{(10.0 \text{ M}\Omega + 100. \text{ k}\Omega)} = 199.009901 \text{ k}\Omega$$

$$V_{\text{voltmeter}} = \frac{12.0 \text{ V}}{199.009 \text{ k}\Omega} \left[\frac{(10.0 \text{ M}\Omega)(100. \text{ k}\Omega)}{(10.0 \text{ M}\Omega + 100. \text{ k}\Omega)} \right] = 5.97 \text{ V}$$

$$\text{The percentage change is } \frac{6.00 \text{ V} - 5.97 \text{ V}}{6.00 \text{ V}} = 0.500\%.$$

ROUND: The percentage change is 0.500%.

DOUBLE-CHECK: It make sense that the voltmeter will reduce the voltage since any voltmeter (with non-infinite resistance) will draw a small amount of current.

- 26.45.** The equation for the charge of a capacitor in an RC circuit over time is $Q(t) = Q_{\text{initial}} e^{-t/\tau}$. Use the equations: $\tau = RC$, $R = 100. \Omega + 200. \Omega = 300. \Omega$, $C = 10.0 \text{ mF}$, $\ln\left(\frac{Q(t)}{Q_{\text{initial}}}\right) = -t / \tau$,
 $t = -\tau \ln\left(\frac{Q(t)}{Q_{\text{initial}}}\right)$, and $t = -(300. \Omega)(10.0 \text{ mF}) \ln\left(\frac{5.00 \text{ mC}}{100. \text{ mC}}\right) = 8.99 \text{ s}$.

- 26.46.** The circuit can be easily simplified to

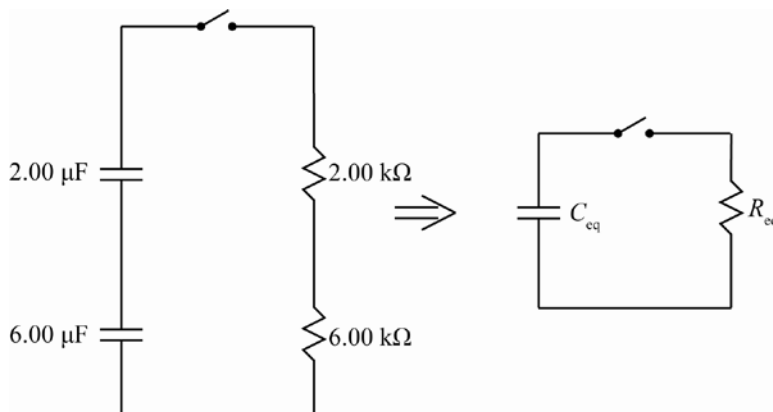

where $R_{\text{eq}} = 2.00 \text{ k}\Omega + 6.00 \text{ k}\Omega = 8.00 \text{ k}\Omega$ and $C_{\text{eq}} = \left[(1/2.00 \mu\text{F}) + (1/6.00 \mu\text{F}) \right]^{-1} = 1.50 \mu\text{F}$. The time constant is then $\tau = R_{\text{eq}} C_{\text{eq}} = (8.00 \text{ k}\Omega)(1.50 \mu\text{F}) = 12.0 \text{ ms}$. The initial charge of the $2.00 \mu\text{F}$ capacitor, with initial potential $V = 10.0 \text{ V}$, is $q_0 = CV = (2.00 \mu\text{F})(10.0 \text{ V}) = 2.00 \cdot 10^{-5} \text{ C}$. The charge decays as $q(t) = q_0 e^{-t/\tau}$. When $t = \frac{\tau}{2}$, the charge left is
 $q\left(\frac{\tau}{2}\right) = q_0 e^{-1/2} = 0.6065 q_0 = 0.6065 \cdot (2 \cdot 10^{-5} \text{ C}) = 1.213 \cdot 10^{-5} \text{ C}$.

- 26.47.** Since the position of the resistor with respect to the capacitor is irrelevant, the circuit is simplified to:

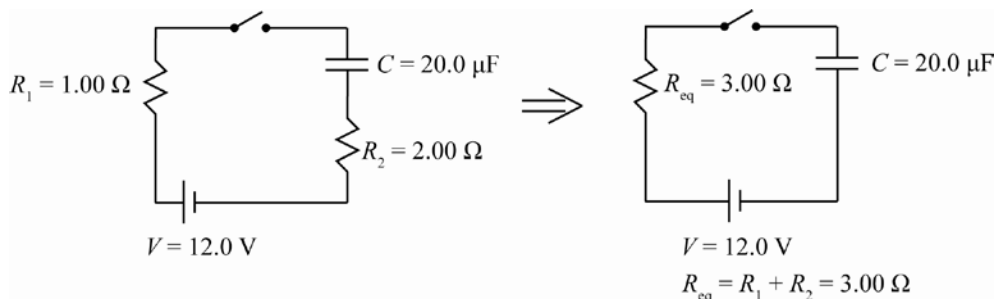

The maximum charge of the capacitor is $q_0 = C\Delta V = (20.0 \mu\text{F})(12.0 \text{ V}) = 2.40 \cdot 10^{-4} \text{ C}$. In general, the capacitor charges as $q(t) = q_0 \left(1 - e^{-t/RC}\right)$. When $q(t) = (1/2)q_0$:

$$\frac{1}{2}q_0 = q_0 \left(1 - e^{-t/RC}\right) \Rightarrow e^{-t/RC} = \frac{1}{2} \Rightarrow t = -RC \ln\left(\frac{1}{2}\right) = RC \ln(2).$$

Therefore, $t = (3.00 \Omega)(20.0 \mu\text{F}) \ln(2) = 4.16 \mu\text{s}$.

26.48. By Ohm's law, the power, $P = 1.21 \text{ GW}$, is related to potential, $V = 12.0 \text{ V}$, and resistance, R , by

$$P = \frac{V^2}{R} \Rightarrow R = \frac{V^2}{P} = \frac{(12.0 \text{ V})^2}{1.21 \text{ GW}} = 119 \text{ n}\Omega.$$

The time to charge the capacitor, $C = 1.00 \text{ F}$, to 90.0% is $q(t) = q_0 \left(1 - e^{-\frac{t}{RC}} \right) = 0.900q_0 \Rightarrow e^{-\frac{t}{RC}} = 0.100$.

Therefore, $t = -RC \ln(0.100) = -(119 \text{ n}\Omega)(1.00 \text{ F}) \ln(0.100) = 274 \cdot 10^{-9} \text{ s} = 274 \text{ ns}$.

26.49. **THINK:** The charge on the capacitor, $C = 90.0 \text{ }\mu\text{F}$, decays exponentially through the resistor, $R = 60.0 \text{ }\Omega$. The energy on the capacitor is proportional to the square of the charge, so the energy also decays exponentially. If 80.0% of the energy is lost, then 20.0% is left on the capacitor.

SKETCH:

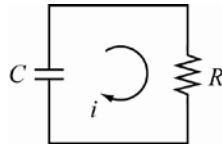

RESEARCH: The charge on the capacitor is given by $q(t) = q_0 e^{-t/RC}$. The energy on the capacitor is given

by $E(t) = \frac{1}{2} \frac{q(t)^2}{C}$. To determine the time when there is 20.0% energy remaining, consider the equation:

$$E(t) = 0.200E(0).$$

SIMPLIFY: Determine time, t :

$$\begin{aligned} E(t) &= \frac{q(t)^2}{2C} = \frac{q_0^2 e^{-2t/RC}}{2C} = 0.200E(0) = 0.200 \frac{q_0^2}{2C} \\ \Rightarrow e^{-2t/RC} &= 0.200 \Rightarrow \frac{-2t}{RC} = \ln(0.200) \Rightarrow t = -\frac{RC}{2} \ln(0.200). \end{aligned}$$

CALCULATE: $t = -\frac{60.0 \text{ }\Omega (90.0 \times 10^{-6} \text{ F})}{2} \ln(0.200) = 4.3455 \cdot 10^{-3} \text{ s}$

ROUND: To three significant figures, $t = 4.35 \text{ ms}$

DOUBLE-CHECK: After $t = 4.35 \text{ ms}$, the charge on the capacitor is 0.451 of the maximum charge. This value squared gives 0.203, which is 20.0% with rounding error considered.

26.50. **THINK:** After sufficient time, the potential on both plates (area $A = 2.00 \text{ cm}^2$ and separation $d = 0.100 \text{ mm}$) will be $\Delta V = 60.0 \text{ V}$. Since the capacitors are in series, the total charge on each will be the same. The potential drop across a capacitor is needed to find its electric field. The second capacitor has dielectric constant $\kappa = 7.00$ and dielectric strength $S = 5.70 \text{ kV/mm}$.

SKETCH:

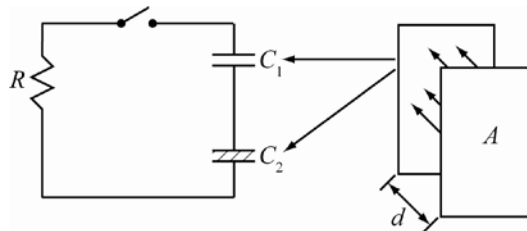

RESEARCH: The capacitance of the air filled capacitor is $C_1 = \frac{\epsilon_0 A}{d}$, and that with the dielectric is $C_2 = \frac{\kappa \epsilon_0 A}{d}$. The charge on a capacitor is $Q = C\Delta V$. The energy stored in a capacitor is $U = \frac{Q^2}{2C}$. The electric field inside a capacitor is $E = \frac{V}{d}$.

SIMPLIFY:

(a) Equivalent capacitance is

$$C_{\text{eq}} = \left(\frac{1}{C_1} + \frac{1}{C_2} \right)^{-1} = \left(\frac{d}{\epsilon_0 A} + \frac{d}{\kappa \epsilon_0 A} \right)^{-1} = \frac{\epsilon_0 A}{d} \left(1 + \frac{1}{\kappa} \right)^{-1} = \frac{\epsilon_0 A}{d} \left(\frac{\kappa}{\kappa + 1} \right).$$

Charge on the first capacitor is $Q = Q_1 = C_{\text{eq}} \Delta V$.

(b) Charge on the second capacitor is $Q = Q_2 = C_{\text{eq}} \Delta V$.

(c) The total energy on both plates is $U = \frac{Q^2}{2C_{\text{eq}}} = \frac{C_{\text{eq}}^2 \Delta V^2}{2C_{\text{eq}}} = \frac{1}{2} C_{\text{eq}} \Delta V^2$.

(d) The potential drop across the second capacitor is $\Delta V_2 = \frac{Q_2}{C_2} = \frac{Qd}{\kappa \epsilon_0 A}$. The electric field across it is then

$$E_2 = \frac{\Delta V_2}{d} = \frac{Q}{\kappa \epsilon_0 A}.$$

CALCULATE:

$$(a) C_{\text{eq}} = \frac{7.00}{7.00 + 1} \left[\frac{(8.854 \cdot 10^{-12} \text{ C}^2 / (\text{N m}^2))(2.00 \cdot 10^{-4} \text{ m}^2)}{1.00 \cdot 10^{-4} \text{ m}} \right] = 1.54945 \cdot 10^{-11} \text{ F}$$

$$Q_1 = (1.54945 \cdot 10^{-11} \text{ F})(60.0 \text{ V}) = 9.2967 \cdot 10^{-10} \text{ C}$$

$$(b) Q_2 = 9.2967 \cdot 10^{-10} \text{ C}$$

$$(c) U = \frac{1}{2} (1.54945 \cdot 10^{-11} \text{ F})(60.0 \text{ V})^2 = 2.789 \cdot 10^{-8} \text{ J}$$

$$(d) E_2 = \frac{9.2967 \cdot 10^{-10} \text{ C}}{7.00(8.854 \cdot 10^{-12} \text{ C}^2 / (\text{N m}^2))(2.00 \cdot 10^{-4} \text{ m}^2)} = 75,000 \text{ V/m}$$

ROUND:

$$(a) Q_1 = 9.30 \cdot 10^{-10} \text{ C}$$

$$(b) Q_2 = 9.30 \cdot 10^{-10} \text{ C}$$

$$(c) U = 2.79 \cdot 10^{-8} \text{ J}$$

$$(d) E_2 = 75.0 \text{ kV/m}$$

DOUBLE-CHECK: Numerically, $\Delta V_2 = 7.5 \text{ V}$ and $\Delta V_1 = Qd / \epsilon_0 A = 52.5 \text{ V}$, so $\Delta V_1 + \Delta V_2 = 60 \text{ V} = \Delta V$, which means energy was conserved. Also, since $E_2 < S$ (dielectric strength), this capacitor is clearly viable, so it makes sense.

26.51. THINK: Since the dielectric material ($\kappa = 2.5$, $d = 50.0 \mu\text{m}$ and $\rho = 4.0 \cdot 10^{12} \Omega \text{ m}$) acts as the resistor and it shares the same cross sectional area as the capacitor, $C = 0.050 \mu\text{F}$, a time constant, τ , should be independent of the actual capacitance and resistance, and only depend on the material.

SKETCH:

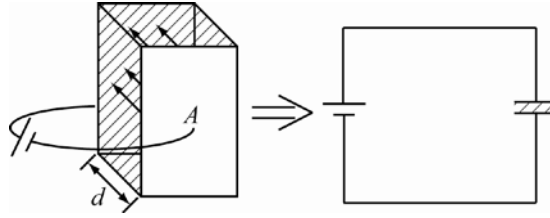

RESEARCH: The capacitance is $C = \kappa\epsilon_0 A / d$. The resistance is $R = \rho d / A$. The time constant is $\tau = RC$.

SIMPLIFY: The time constant is $\tau = RC = \left(\frac{\rho d}{A}\right)\left(\frac{\kappa\epsilon_0 A}{d}\right) = \kappa\rho\epsilon_0$.

CALCULATE: $\tau = 2.5(4.0 \cdot 10^{12} \Omega \text{ m})\left(8.85 \cdot 10^{-12} \text{ C}^2 / (\text{N m}^2)\right) = 88.5 \text{ s}$

ROUND: $\tau = 89 \text{ s}$

DOUBLE-CHECK: While this value seems relatively high, it is nonetheless perfectly reasonable. The high resistivity and greater than 1 dielectric material, both imply bigger R and C , so a high τ is reasonable.

- 26.52. THINK:** Since the current varies with time due to the charging of the capacitor, $C = 2.00 \text{ mF}$, the energy lost due to heat from the resistor, $R = 100. \Omega$, is found by integrating the power dissipation of the resistor over time. When the capacitor is fully charged it has the same potential as the battery, $\Delta V = 12.0 \text{ V}$.

SKETCH:

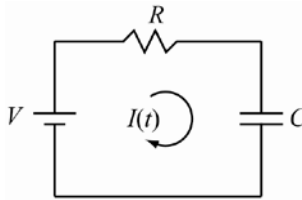

RESEARCH: When the capacitor is fully charged, the energy stored in it is $U = (1/2)CAV^2$. The power across the resistor is $P = I^2R$. The current decreases exponentially by $i(t) = i_0 e^{-t/\tau}$, where $\tau = RC$ and $i_0 = V/R$.

SIMPLIFY: Energy across the capacitor: $U_C = (1/2)CV^2$. Energy dissipated through the resistor:

$$U_R = \int_0^\infty P(t) dt = \int_0^\infty (I(t))^2 R dt = R \int_0^\infty (I_0)^2 e^{-2t/\tau} dt = R \int_0^\infty \left(\frac{V}{R}\right)^2 e^{-2t/\tau} dt = \frac{V^2}{R} \int_0^\infty e^{-2t/\tau} dt.$$

Therefore,

$$U_R = \frac{V^2}{R} \left[-\frac{\tau}{2} e^{-2t/\tau} \right]_0^\infty = \frac{V^2}{R} \left(0 - \left(-\frac{\tau}{2}\right) e^0 \right) = \frac{V^2 \tau}{2R}.$$

Therefore, $\tau = RC$, $U_R = \frac{V^2(RC)}{2R} = \frac{1}{2}CV^2$ and $U_C = U_R$.

CALCULATE: $U_C = U_R = (1/2)(2.00 \text{ mF})(12.0 \text{ V})^2 = 0.144 \text{ J}$

ROUND: $U_C = U_R = 0.144 \text{ J}$, the same energy for both.

DOUBLE-CHECK: The energy stored in capacitor is same as energy lost to heat by the resistor. This makes sense if I consider that the total internal energy should stay the same. Therefore, energy lost by resistor is energy gained by capacitor, so energy is conserved.

- 26.53. THINK:** Normally, to be fully discharged the time needs to go to infinity. After $\Delta t = 2.0$ ms, the capacitor should be as close to fully discharged as possible. A good standard of discharge is when the final charge is less than 0.01% which roughly corresponds to a time of 10τ , where τ is the time constant of the circuit. From τ , the capacitance, C , can be determined and using $E = 5.0$ J the potential difference on the plates is found. $R = 10.0$ k Ω .

SKETCH: Not required.

RESEARCH: The time constant is approximated as $\tau = (1/10)\Delta t$, and is also $\tau = RC$. The energy stored in the capacitor is $E = (1/2)C\Delta V^2$.

SIMPLIFY: The capacitance is $C = \frac{\tau}{R} = \frac{\Delta t}{10R}$ the potential difference is then $\Delta V = \sqrt{\frac{2E}{C}}$.

CALCULATE: $C = \frac{2.0 \text{ ms}}{10 \cdot 10.0 \text{ k}\Omega} = 2.0 \cdot 10^{-8} \text{ F} = 0.020 \mu\text{F}$ $\Delta V = \sqrt{\frac{2(5.0 \text{ J})}{0.020 \mu\text{F}}} = 22361 \text{ V}$

ROUND: $C = 0.0200 \mu\text{F}$, $\Delta V = 22.4 \text{ kV}$

DOUBLE-CHECK: If instead I chose the capacitor to be only 99% discharged, corresponding to only $\Delta t = 5\tau$, the potential across the capacitor would be about 16 kV, which is also high, so our choice is reasonable.

- 26.54. THINK:**

(a) When switch S_1 is closed, the current flows solely through resistors $R_1 = 100. \Omega$ and $R_3 = 300. \Omega$ which are in series with a battery $V_{\text{emf}} = 6.00$ V.

(b) When switch S_2 is closed, the current splits between $R_1 = 100. \Omega$ in one branch and $R_2 = 200. \Omega$ with a capacitor $C = 4.00$ mF in the other branch. Initially there is no charge on the capacitor so there is no potential drop across it, meaning it does not initially contribute to the current. These branches are then in series with resistor $R_3 = 300. \Omega$ and battery $V_{\text{emf}} = 6.00$ V.

(c) The capacitor, $C = 4.00$ mF, will charge but only through resistor $R_2 = 200. \Omega$, so as to give a time constant τ . As it charges over $t = 10.0$ min = 600. s, the current through that branch will decrease exponentially.

(d) When the capacitor, $C = 4.00$ mF, is fully charged, no current flows through that branch. This means that initially, the battery $V_{\text{emf}} = 6.00$ V, is in series with resistors $R_1 = 100. \Omega$ and $R_3 = 300. \Omega$. The initial potential in the capacitor must still equal the potential drop across resistor R_1 . When switch S_1 is opened, the capacitor begins to discharge through resistors R_1 and $R_2 = 200. \Omega$. As capacitor discharges, the current will decrease exponentially to $i_f = 1.00$ mA.

SKETCH:

(a)

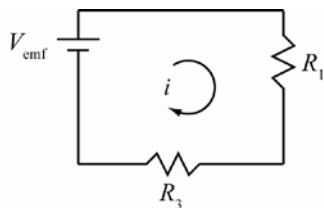

(b)

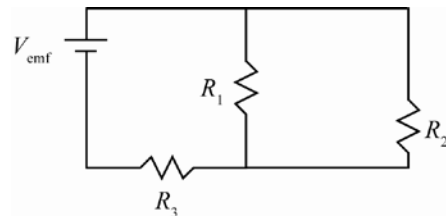

(c)

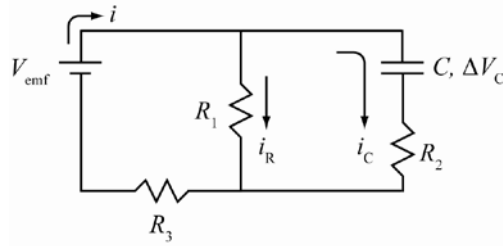

(d)

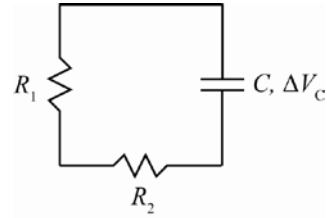
RESEARCH:

 (a) The equivalent resistance is $R_{\text{eq}} = R_1 + R_3$. By Ohm's Law, the current through circuit is $i_1 = V_{\text{emf}} / R_{\text{eq}}$.

 (b) The equivalent resistance of resistors 1 and 2 is $R_{12} = (1/R_1 + 1/R_2)^{-1}$. The total equivalent resistance is then $R_{\text{eq}} = R_3 + R_{12}$. By Ohm's law, the current through circuit is $I_2 = V_{\text{emf}} / R_{\text{eq}}$.

 (c) As the capacitor charges, the current through it decrease as $i_C(t) = i_0 e^{-t/\tau}$ where, $\tau = R_2 C$. The current through resistor R_1 is i_R and the total current out of the battery is $i = i_R + i_C$.

 (d) Potential drop across R_1 initially is $i_1 R_1 = \Delta V_1 = \Delta V_C$. Current decays exponentially as $i(t) = i_0 e^{-t/\tau}$, where $\tau = (R_1 + R_2)C$ and by Ohm's law, $i_0 = \Delta V_C / (R_1 + R_2)$.

SIMPLIFY:

(a)
$$i_1 = \frac{V_{\text{emf}}}{R_{\text{eq}}} = \frac{V_{\text{emf}}}{R_1 + R_3}$$

(b)
$$R_{12} = \left(\frac{1}{R_1} + \frac{1}{R_2} \right)^{-1} = \frac{R_1 R_2}{R_1 + R_2}, \quad i_2 = \frac{V_{\text{emf}}}{R_{\text{eq}}} = \frac{V_{\text{emf}}}{R_3 + R_{12}}$$

 (c) Calculate $i_C(t)$ and infer i from it.

 (d) Initial current is $i_0 = \frac{\Delta V_C}{R_1 + R_2} = \frac{R_1 i_1}{R_1 + R_2}$ when $i(t) = i_f$. Therefore,

$$i_f = \frac{R_1 i_1}{R_1 + R_2} e^{-t/\tau} \Rightarrow \frac{i_f (R_1 + R_2)}{R_1 i_1} = e^{-t/\tau} \Rightarrow t = -\tau \ln \left(\frac{i_f (R_1 + R_2)}{R_1 i_1} \right)$$

CALCULATE:

(a)
$$i_1 = \frac{6.00 \text{ V}}{100. \Omega + 300. \Omega} = 0.0150 \text{ A} = 15.0 \text{ mA}$$

(b)
$$R_{12} = \frac{(100. \Omega)(200. \Omega)}{100. \Omega + 200. \Omega} = 66.67 \Omega, \quad i_2 = \frac{6.00 \text{ V}}{300. \Omega + 66.67 \Omega} = 0.01636 \text{ A} = 16.36 \text{ mA}$$

 (c) $\tau = (200. \Omega)(4.00 \text{ mF}) = 0.800 \text{ s}$. $i_C(t) = i_0 e^{\frac{-600. \text{ s}}{0.8 \text{ s}}} = i_0 e^{-750} \approx 0 \text{ A}$. Regardless of what i_0 is after 10.0 min, the current through that branch is effectively 0.0 A. Therefore, $i = i_R = 15.0 \text{ mA}$. Since there is no current through the capacitor, the circuit is equivalent to having switch S_2 open, as in part (a) so current through battery is then the same as in part (a).

(d)
$$\tau = (100. \Omega + 200. \Omega)(4.0 \text{ mF}) = 1.20 \text{ s} \text{ and } t = -(1.20 \text{ s}) \ln \left(\frac{(1.00 \text{ mA})(100. \Omega + 200. \Omega)}{(100. \Omega)(15.0 \text{ mA})} \right) = 1.9313 \text{ s}$$

ROUND:

(a) $i_1 = 15.0 \text{ mA}$

(b) $i_2 = 16.4 \text{ mA}$

(c) $i = 15.0 \text{ mA}$

(d) $t = 1.93 \text{ s}$

DOUBLE-CHECK:

- (a) This is a reasonable value for current.
 (b) Since I added a resistor in parallel, the overall resistance is expected to decrease, and hence the current increase, so it makes sense.
 (c) From part (b), I saw the overall current was greater than in part (a). If a piece of the current found in part (b) dies off, the final current should be smaller, so it makes sense.
 (d) Since I know the current should reduce to zero in $t = 600. \text{ s}$, then reducing by 80.0% in only 1.93 s is very reasonable so it makes sense.

- 26.55. THINK:** The capacitor, $C = 2.00 \mu\text{F}$, charges via the battery, $\Delta V = 10.0 \text{ V}$, through resistor, $R_1 = 10.0 \Omega$, so the resistors, $R_2 = 4.00 \Omega$ and $R_3 = 10.0 \Omega$, can be simplified to be in parallel. After a long time, the capacitor becomes fully charged and no current goes through it. The potential drop across it is then the same as the drop across R_2 and R_3 . The energy of the capacitor is proportional to the square of the potential drop across it. The total energy lost across R_3 is determined by integrating the power across it over time.

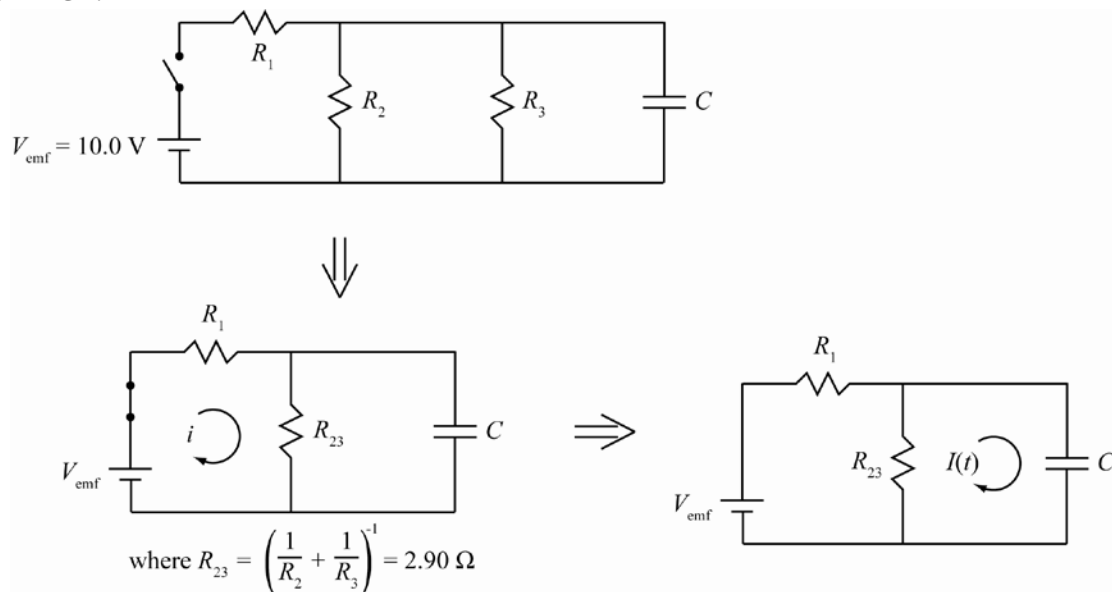
SKETCH:

RESEARCH: The current through the circuit after a long time is $i = V_{\text{emf}} / (R_1 + R_{23})$. Resistors in parallel add as $R_{23} = (R_2^{-1} + R_3^{-1})^{-1}$. The potential drop across the capacitor is $\Delta V_C = iR_{23}$. The energy in the capacitor is given by $E = C(\Delta V_C)^2 / 2$. When the switch is open, the current through R_3 is $i_3 = \Delta V_C / R_3$. The current across R_3 varies as $i_3(t) = i_3 e^{-t/R_{23}C}$. The power across R_3 is given by $P_3 = i_3^2(t)R_3$. The energy across R_3 is given by $E_3 = \int_0^\infty P_3(t) dt$.

SIMPLIFY:

- (a) The potential drop across the capacitor is given by: $\Delta V_C = iR_{23} = \frac{V_{\text{emf}} R_{23}}{R_1 + R_{23}}$.
 (b) The energy in the capacitor is given by $E = \frac{1}{2} C (\Delta V_C)^2$.

(c) The energy across R_3 is given by: $E_3 = \int_0^\infty P_3(t) dt = \int_0^\infty R_3 i_3^2 e^{-2t/R_{23}C} dt = \frac{\Delta V_C^2}{R_3} \int_0^\infty e^{-2t/R_{23}C} dt$

$$= \frac{\Delta V_C^2}{R_3} \left[-\frac{R_{23}C}{2} e^{-2t/R_{23}C} \right]_{t=0}^{t=\infty} = \frac{\Delta V_C^2}{R_3} \left[0 + \frac{R_{23}C}{2} \right] = \frac{\Delta V_C^2 R_{23}C}{2R_3}.$$

CALCULATE:

(a) $R_{23} = \left((10.0 \Omega)^{-1} + (4.00 \Omega)^{-1} \right)^{-1} = 2.86 \Omega$, $\Delta V_C = \frac{(10.0 \text{ V})(2.86 \Omega)}{10.0 \Omega + 2.86 \Omega} = 2.22 \text{ V}$

(b) $E = \frac{1}{2} (2.00 \mu\text{F})(2.22 \text{ V})^2 = 4.938 \cdot 10^{-6} \text{ J}$

(c) $E_3 = \frac{(2.22 \text{ V})^2 (2.86 \Omega)(2.00 \mu\text{F})}{2(10.0 \Omega)} = 1.411 \cdot 10^{-6} \text{ J}$

ROUND:

(a) $\Delta V_C = 2.22 \text{ V}$

(b) $E = 4.94 \mu\text{J}$

(c) $E_3 = 1.41 \mu\text{J}$

DOUBLE-CHECK: The energy across R_2 is $E_2 = (\Delta V_C)^2 R_{23}C / 2R_2 = 3.15 \mu\text{J}$. The result makes sense because energy is conserved: $E_2 + E_3 = E$.

26.56. THINK:

(a) The capacitor, $C = 15 \mu\text{F}$ and $\Delta V_C = 100.0 \text{ V}$, is fully discharged when the charge is less than 0.01%, which roughly corresponds to a time of 10τ , where τ is the time constant of the circuit. The resistor in question is a cube of gold of sides $l = 2.5 \text{ mm}$ and resistivity $\rho_R = 2.44 \cdot 10^{-8} \Omega \cdot \text{m}$.

(b) The capacitor, $C = 15 \mu\text{F}$ and $\Delta V_C = 100.0 \text{ V}$, is fully discharged so that all the initial stored energy has gone to heating the resistor. The resistor in question is a cube of gold of size $l = 2.5 \text{ mm}$, density $\rho_D = 19.3 \cdot 10^3 \text{ kg/m}^3$ and specific heat $c = 129 \text{ J/kg} \cdot ^\circ\text{C}$. Assume the cube is initially at room temperature, $T_i = 20.0 ^\circ\text{C}$.

SKETCH:

(a)

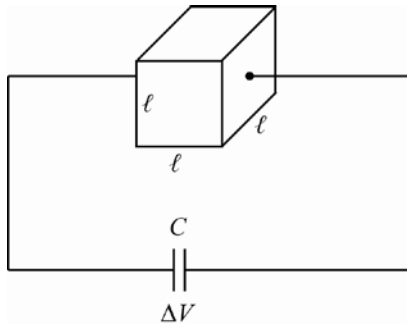

(b)

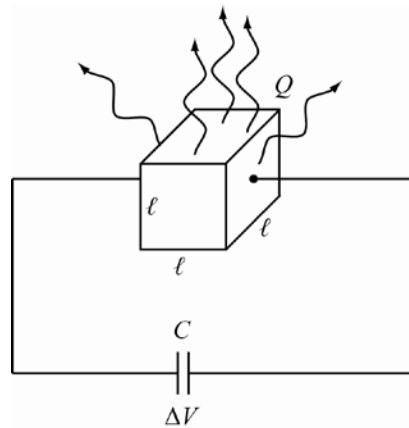

RESEARCH:

(a) The resistance of the cube is $R = \rho_R L / A$. The time constant is $t = 10\tau$.

(b) The energy of the capacitor is $U_c = (1/2)C\Delta V_c^2$. The energy gained by the gold block increases its temperature as $Q = mc\Delta T$. Mass of gold is $m = \rho_D V$. The energy the cube gains is same energy the capacitor dissipates, $U_c = Q$.

SIMPLIFY:

(a) The time for discharge is $t = 10\tau = 10RC = 10\left(\rho_R \frac{L}{A}\right)C = 10\left(\frac{\rho_R l^2}{l}\right)C = \frac{10\rho_R C}{l}$.

(b) To find the final temperature: $Q = U_c \Rightarrow mc\Delta T = (1/2)C(\Delta V)^2$. Therefore,

$$\rho_D V c (T_f - T_i) = \frac{1}{2} C \Delta V_c^2 \Rightarrow T_f = \frac{C \Delta V_c^2}{2 \rho_D l^3 c} + T_i.$$

CALCULATE:

$$(a) \quad t = \frac{10(2.44 \cdot 10^{-8} \Omega \cdot \text{m})(15 \text{ } \mu\text{F})}{(2.5 \text{ mm})} = 1.464 \cdot 10^{-9} \text{ s}$$

$$(b) \quad T_f = \frac{(15 \text{ } \mu\text{F})(100.0 \text{ V})^2}{2(1.93 \cdot 10^4 \text{ kg/m}^3)(2.5 \text{ mm})^3(129 \text{ J/(kg } ^\circ\text{C)})} + 20.0 \text{ } ^\circ\text{C} = 21.928 \text{ } ^\circ\text{C}$$

ROUND:

(a) $t = 1.46 \text{ ns}$

(b) $T_f = 21.9 \text{ } ^\circ\text{C}$

DOUBLE-CHECK:

(a) The calculated value has appropriate units for time, and the magnitude of the value is reasonable for a discharge time.

(b) The temperature of the gold cube does not change appreciable, which would be desirable for real circuits, so it makes sense.

26.57. THINK: Consider any given rung on the ladder to have a total equivalent capacitance of C_0 . Next, determine the equivalent capacitance, C_1 , of C_0 with the next rung and two legs. Since the ladder is infinite, it should not matter where on the ladder the analysis is performed. If C_0 is the equivalent capacitance of all the capacitors beyond some point, then adding another set of capacitors to the mix should not affect anything and C_1 should equal C_0 , giving a recursive relation in C and thus the total equivalent capacitance, in terms of C , can be determined.

SKETCH:

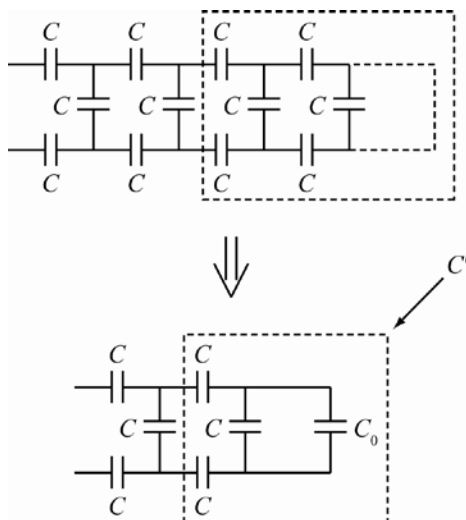

RESEARCH: Capacitors add in series as $C_{\text{eq}}^{-1} = C_1^{-1} + C_2^{-1}$. Capacitors in parallel add as $C_{\text{eq}} = C_1 + C_2$.

SIMPLIFY: C_0 is parallel to C , which gives $C' = C_0 + C$. C' is in series with $2C$'s, which gives:

$$\frac{1}{C_1} = \frac{2}{C} + \frac{1}{C + C_0} = \frac{1}{C_0}.$$

$$\text{Therefore, } 2C_0 + \frac{CC_0}{C + C_0} = C \Rightarrow 2C_0(C + C_0) + CC_0 = C(C + C_0) \Rightarrow 2C_0C + 2C_0^2 + CC_0 = C^2 + CC_0$$

$$\Rightarrow 2C_0^2 + 2CC_0 - C^2 = 0.$$

CALCULATE: Using the quadratic equation: $C_0 = \frac{-2C \pm \sqrt{4C^2 + 8C^2}}{4} = -\frac{C}{2} \pm \frac{\sqrt{12}}{4}C = C \left(\frac{-1 \pm \sqrt{3}}{2} \right)$.

$$C_0 = \left(\frac{\sqrt{3} - 1}{2} \right) C, \text{ since } C_0 \text{ must be positive.}$$

ROUND: Not necessary.

DOUBLE-CHECK: Consider the first rung of three capacitors in series. The equivalent of these is $C/3$. Adding another rung of three capacitors puts one capacitor in parallel with $C/3$ and then two capacitors in series with this to get:

$$C + \frac{C}{3} = \frac{4C}{3} \text{ and then } \left(\frac{2}{C} + \frac{3}{4C} \right)^{-1} = \frac{4}{11}C.$$

Adding another rung performs the same operation as before to get:

$$C + \frac{4}{11}C = \frac{15}{11}C \text{ and then } \left(\frac{2}{C} + \frac{41}{56C} \right)^{-1} = \frac{56}{153}C.$$

Continuing on gives: $C + \frac{15}{41}C = \frac{56}{41}C$ and then $\left(\frac{2}{C} + \frac{153}{209C} \right)^{-1} = \frac{209}{571}C$, $C + \frac{209}{571}C = \frac{780}{571}C$ and then

$$\left(\frac{2}{C} + \frac{571}{780C} \right)^{-1} = 0.36602534C, \quad C + 0.36602534C = 1.36602534C \quad \text{and} \quad \text{therefore}$$

$$\left(\frac{2}{C} + \frac{1}{1.36602534C} \right)^{-1} = 0.366025399C. \text{ The series converges around } C_0 = 0.366025C. \text{ The solution is}$$

$C_0 = (\sqrt{3} - 1/2)C = 0.366025C$, which is the same as the above result. Therefore, by continuously adding rungs to the ladder, it converges to the previous result.

- 26.58.** (a) If the switch is closed for a long time, the capacitor is fully charged and there is no current through that branch. Therefore, the current through The 4.0Ω resistor is $i = 0$ A.
- (b) With no current through R_2 , the potential drop across it is $\Delta V_2 = 0$ V. The two resistors, $R_1 = 6.0 \Omega$ and $R_3 = 8.0 \Omega$, are in series with each other, so the current through them is $i = \Delta V / (R_1 + R_3) = (10.0 \text{ V}) / (14.0 \Omega) = 0.714$ A. The potential drop across the 6.0Ω resistor is $\Delta V_1 = iR_1 = (0.714 \text{ A})(6.0 \Omega) = 4.286$ V, and across the 8.0Ω resistor is $\Delta V_3 = iR_3 = (0.714 \text{ A})(8.0 \Omega) = 5.714$ V. Therefore, to three significant figures, $\Delta V_1 = 4.29$ V, $\Delta V_2 = 0.00$ V and $\Delta V_3 = 5.71$ V.
- (c) The potential on the capacitor is the same as the potential drop across the 8.0Ω resistor since they are parallel, so $\Delta V_C = \Delta V_3 = 5.71$ V.

- 26.59.** (a) The maximum current through the ammeter is $i_A = 1.5$ mA. The ammeter has resistance $R_1 = 75 \Omega$. The current through a resistor is given by $i = V/R$, where V is the potential difference across the resistor. Since current flows through the path of least resistance, when a shunt resistor of small resistance R_{shunt} is connected in parallel with the ammeter, most of the current flows through the shunt resistor. The shunt resistor carries most of the load so that the ammeter is not damaged.

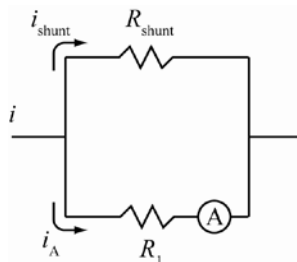

From Kirchoff's rules $i = i_{\text{shunt}} + i_A$ and $i_{\text{shunt}} R_{\text{shunt}} = i_A R_1$. Therefore,

$$i = \frac{i_A R_1}{R_{\text{shunt}}} + i_A = i_A \left(\frac{R_1}{R_{\text{shunt}}} + 1 \right).$$

For known current i_A (measured by ammeter) and known resistances R_1 and R_{shunt} , the new maximum current i can be calculated. Note that $i > i_A$. A shunt resistor is added in parallel with an ammeter so the current can be increased without damaging the ammeter.

(b) From Kirchoff's rules shown above,

$$R_{\text{shunt}} = \frac{i_A R_1}{i_{\text{shunt}}} = \frac{i_A R_1}{i - i_A} = \frac{(1.50 \text{ mA})(75.0 \Omega)}{15.0 \text{ A} - 1.50 \text{ mA}} = 7.501 \cdot 10^{-3} \Omega = 7.50 \text{ m}\Omega.$$

- 26.60.** The potential on the capacitor, $C = 150. \mu\text{F}$, when it is fully charged is $\Delta V = 200. \text{V}$. The potential decreases exponentially as it discharges through $R = 1.00 \text{ M}\Omega$, by $\Delta V(t) = V e^{-t/RC}$. When

$$\Delta V(t) = 50.0 \text{ V}, \quad \Delta V(t) = 50.0 \text{ V} = (200. \text{V}) e^{-\frac{t}{RC}} \Rightarrow e^{-\frac{t}{RC}} = \frac{1}{4}. \quad \text{Therefore, the result is}$$

$$t = RC \ln(4.00) = 207.94 \text{ s} = 208 \text{ s} \text{ or } 3.47 \text{ min.}$$

- 26.61.** The capacitor, C , discharges through the bulb, $R_f = 2.5 \text{ k}\Omega$, in $\Delta t_d = 0.20 \text{ ms}$. The charging time is $\Delta t_c = 0.80 \text{ ms}$. For simplicity assume the charging and discharging time are the time constants of the circuits. Therefore, $\Delta t_d = \tau_d = R_f C \Rightarrow C = \frac{\Delta t_d}{R_f} = \frac{0.20 \text{ ms}}{2.5 \text{ k}\Omega} = 8.0 \cdot 10^{-8} \text{ F} = 80. \text{ nF}$, and

$$\Delta t_c = \tau_c = RC \Rightarrow R = \frac{\Delta t_c}{C} = \frac{0.80 \text{ ms}}{80. \text{ nF}} = 10. \text{ k}\Omega.$$

- 26.62.** The potential, V_{emf} , of the battery is the same with ammeter, $R_0 = 53 \Omega$, as without. The external resistance $R = 1130 \Omega$, has a current of $I = 5.25 \text{ mA}$ with ammeter, so by Ohm's law

$$V_{\text{emf}} = i(R_0 + R) = i'R \Rightarrow i' = \frac{i(R_0 + R)}{R} = \frac{(5.25 \text{ mA})(53 \Omega + 1130 \Omega)}{1130 \Omega} = 5.4962 \text{ mA} = 5.50 \text{ mA}.$$

- 26.63. THINK:** When the switch is set to X for a long time, the capacitor, $C = 10.0 \mu\text{F}$, charges fully so that it has the same potential as the battery, $\Delta V_C = V_{\text{emf}} = 9.00 \text{ V}$. After placing the switch on Y, the capacitor discharges through resistor $R_2 = 40.0 \Omega$ and decreases exponentially for both immediately ($t = 0 \text{ s}$) and $t = 1.00 \text{ ms}$ after the switch.

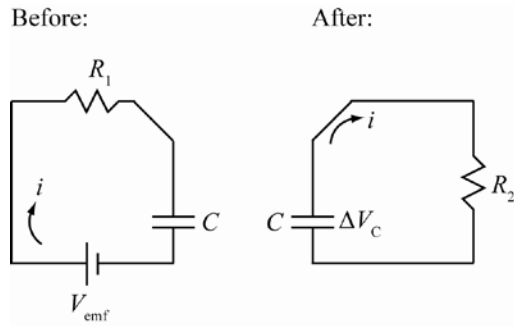
SKETCH:

RESEARCH: By Ohm's law, the current initially is $i_0 = \Delta V_C / R_2$, where $\Delta V_C = V_{\text{emf}}$. Current decays exponentially as $i(t) = i_0 e^{-t/\tau}$, where $\tau = RC$.

SIMPLIFY:

(a) Initial current is $i_0 = \Delta V_C / R_2 = V_{\text{emf}} / R_2$.

(b) After $t = 1$ ms, current is $i(t) = I_0 e^{-t/\tau} = i_0 e^{-t/RC}$.

CALCULATE:

(a) $i_0 = \frac{9.00 \text{ V}}{40.0 \Omega} = 0.225 \text{ A}$

(b) $i(1.00 \text{ ms}) = (0.225 \text{ A}) e^{\frac{-1.00 \text{ ms}}{(40.0 \Omega)(100 \mu\text{F})}} = 0.01847 \text{ A}$

ROUND:

(a) $i_0 = 225 \text{ mA}$

(b) $i(1.00 \text{ ms}) = 18.5 \text{ mA}$

DOUBLE-CHECK: After only 1.00 ms, the current decreases by almost 90.0%, which would make this a desirable circuit, so it makes sense.

- 26.64. THINK:** Since the two resistors, $R = 2.2 \text{ k}\Omega$, the two capacitors, $C = 3.8 \mu\text{F}$, and the battery, $V_{\text{emf}} = 12.0 \text{ V}$, are all in series, the order doesn't matter, so equivalent resistance and capacitance are used to determine the time constant, τ . The current then decreases exponentially from its initial current to $i_f = 1.50 \text{ mA}$ in time t .

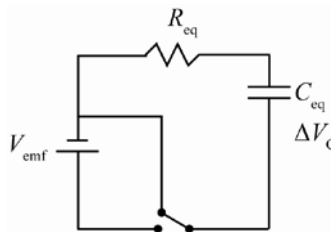
SKETCH:

RESEARCH: The equivalent resistance is $R_{\text{eq}} = R + R = 2R$, and the equivalent capacitance is $C_{\text{eq}} = (1/C + 1/C)^{-1} = C/2$. Initial potential in capacitor, $\Delta V_C = V_{\text{emf}}$. By Ohm's law, the initial current is $i_0 = \Delta V_C / R_{\text{eq}}$.

SIMPLIFY: The current at time t is $i(t) = i_0 e^{-t/\tau} = \frac{\Delta V_C}{R_{eq}} e^{-\frac{t}{R_{eq} C_{eq}}} = \frac{\Delta V_C}{2R} e^{-\frac{t}{(2R)(C/2)}} = \frac{\Delta V_C}{2R} e^{-\frac{t}{RC}}$.

$$i(t) = i_f \Rightarrow i_f = \frac{\Delta V_C}{2R} e^{-\frac{t}{RC}} \Rightarrow \frac{2Ri_f}{\Delta V_C} = e^{-\frac{t}{RC}} \Rightarrow t = -RC \ln \left(\frac{2Ri_f}{\Delta V_C} \right)$$

CALCULATE: $t = -(2.20 \text{ k}\Omega)(3.00 \mu\text{F}) \ln \left(\frac{2(2.20 \text{ k}\Omega)(1.50 \text{ mA})}{12.0 \text{ V}} \right) = 4.998 \text{ s}$

ROUND: $t = 5.00 \text{ ms}$

DOUBLE-CHECK: The initial value of the current was about 2.7 mA. The circuit decays to about half its original current in roughly 5 ms, which makes this a desirable circuit, so it makes sense.

- 26.65. The charge on the capacitor increases exponentially with a time constant, $\tau = 3.1 \text{ s}$. Since the amount of energy in the capacitor is proportional to the square of the charge, the energy also increases exponentially.

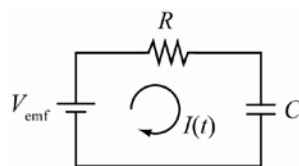

The charge on the capacitor is given by $q(t) = q_0(1 - e^{-t/\tau})$. The energy on the capacitor is given by $E(t) = q^2(t)/2C$. The time to get to half of the maximum energy is given by $E(t) = E_{\max}/2$, where $E_{\max} = q_0^2/2C$. This gives:

$$E(t) = \frac{1}{2} E_{\max} = \frac{q_0^2}{4C} = \frac{q^2(t)}{2C} = \frac{q_0^2(1 - e^{-t/\tau})^2}{2C} \Rightarrow 1 - e^{-t/\tau} = \frac{1}{\sqrt{2}} \Rightarrow$$

$$t = -\tau \ln \left(1 - \frac{1}{\sqrt{2}} \right) = -(3.1 \text{ s}) \ln \left(1 - \frac{1}{\sqrt{2}} \right) = 3.8 \text{ s}.$$

- 26.66. **THINK:** When the switch is closed for a long time, the capacitors, $C_1 = 1.00 \mu\text{F}$ and $C_2 = 2.00 \mu\text{F}$, are fully charged so no current flows through them, and thus the current only flows through the two resistors, $R_1 = 1.00 \text{ k}\Omega$ and $R_2 = 2.00 \text{ k}\Omega$, driven by a battery $V_{\text{emf}} = 10.0 \text{ V}$. At this point, the potential drop across each resistor is equal to the potential on its complementary capacitor. Since the capacitors are in series, they have the same charge on them.

SKETCH:

(a)

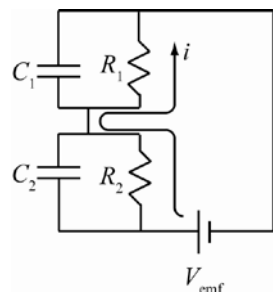

(b)

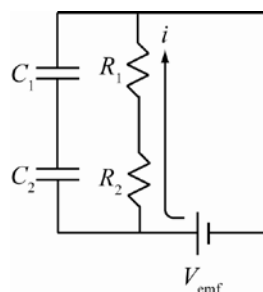

RESEARCH: The current, by Ohm's law is found in both cases as $i = V_{\text{emf}}/(R_1 + R_2)$. When the switch is closed, the potential drop across capacitor C_j is $\Delta V_j = Q_j/C_j = IR_j$ (for $j=1,2$). When switch is open, charge on each plate is $Q = C_{eq} V_{\text{emf}}$.

SIMPLIFY:

(a) The charges on the capacitor are given by: $Q_j/C_j = iR_j \Rightarrow Q_j = iR_jC_j = \Delta V_{\text{emf}}R_jC_j/(R_1 + R_2)$.

$$Q_1 = V_{\text{emf}}R_1C_1/(R_1 + R_2) \text{ and } Q_2 = V_{\text{emf}}R_2C_2/(R_1 + R_2).$$

(b) The charge on each capacitor is $Q = C_{\text{eq}}V_{\text{emf}} = (1/C_1 + 1/C_2)^{-1}V_{\text{emf}} = C_1C_2/(C_1 + C_2)V_{\text{emf}}$.

CALCULATE:

$$(a) \quad Q_1 = \frac{(10.0 \text{ V})(1.00 \text{ k}\Omega)(1.00 \text{ }\mu\text{F})}{1.00 \text{ k}\Omega + 2.00 \text{ k}\Omega} = 3.33 \cdot 10^{-6} \text{ C} \text{ and } Q_2 = \frac{(10.0 \text{ V})(2.00 \text{ k}\Omega)(2.00 \text{ }\mu\text{F})}{1.00 \text{ k}\Omega + 2.00 \text{ k}\Omega} = 1.33 \cdot 10^{-5} \text{ C}$$

$$(b) \quad Q = \frac{(10.0 \text{ V})(1.00 \text{ }\mu\text{F})(2.00 \text{ }\mu\text{F})}{1.00 \text{ }\mu\text{F} + 2.00 \text{ }\mu\text{F}} = 6.67 \cdot 10^{-6} \text{ C}$$

ROUND:

(a) $Q_1 = 3.33 \text{ }\mu\text{C}$, and $Q_2 = 13.3 \text{ }\mu\text{C}$

(b) $Q = 6.67 \text{ }\mu\text{C}$

DOUBLE-CHECK: More charge builds up when the capacitors have their own resistor than when they are paired together. This is because even though the potential drop across them is the same in both cases, when the switch is open, the overall capacitance of the circuit is less than the sum of two. So a smaller C gives a smaller Q , so it makes sense.

- 26.67. THINK:** From Kirchoff's rules, an equation can be obtained for the sum of the three currents, i_1 , i_2 and i_3 , and two equations for the two inner loops of the circuit. This will yield 3 equations for 3 unknowns (the currents) and can be solved by simple substitution. Once the currents are known, the power over each resistor is found via Ohm's law. $R_1 = 10.0 \text{ }\Omega$, $R_2 = 20.0 \text{ }\Omega$, $R_3 = 30.0 \text{ }\Omega$, $V_1 = 15.0 \text{ V}$ and $V_2 = 9.00 \text{ V}$.

SKETCH:

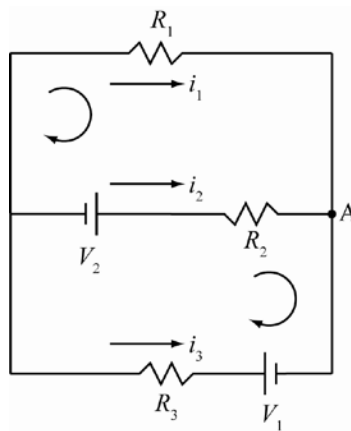

RESEARCH: Looking at point A, the three currents all flow into it, so $i_1 + i_2 + i_3 = 0$. Going clockwise in each loop (upper and lower) yields two more equations: $-i_1R_1 + i_2R_2 - V_2 = 0$ and $V_2 - i_2R_2 + V_1 + i_3R_3 = 0$.

The power across a resistor is $P = i^2R$.

SIMPLIFY: Since all resistances and all voltages are known, the first three equations can be solved for the three separate currents:

$$i_1 + i_2 + i_3 = 0 \Rightarrow i_3 = -i_1 - i_2, \text{ and } -i_1R_1 + i_2R_2 - V_2 = 0, \text{ then}$$

$$-i_1R_1 + i_2R_2 - V_2 = 0 \Rightarrow i_1 = \frac{i_2R_2 - V_2}{R_1}.$$

$$V_2 - i_2 R_2 + V_1 + i_3 R_3 = 0 \Rightarrow V_2 - i_2 R_2 + V_1 + (-i_1 - i_2) R_3 = 0$$

$$\Rightarrow V_2 - i_2 R_2 + V_1 + \left(-\left(\frac{i_2 R_2 - V_2}{R_1} \right) - i_2 \right) R_3 = 0 \Rightarrow i_2 = \frac{R_1 V_1 + V_2 (R_1 + R_3)}{R_1 R_2 + R_1 R_3 + R_2 R_3}.$$

$$i_3 = -i_1 - i_2.$$

The power across each is then $P_1 = i_1^2 R_1$, $P_2 = i_2^2 R_2$ and $P_3 = i_3^2 R_3$.

CALCULATE:

$$i_2 = \frac{R_1 V_1 + V_2 (R_1 + R_3)}{R_1 R_2 + R_1 R_3 + R_2 R_3} = \frac{(10.0 \Omega)(15.0 \text{ V}) + (9.00 \text{ V})(10.0 \Omega + 30.0 \Omega)}{(10.0 \Omega)(20.0 \Omega) + (10.0 \Omega)(30.0 \Omega) + (20.0 \Omega)(30.0 \Omega)} = 0.4636 \text{ A}$$

$$i_1 = \frac{i_2 R_2 - V_2}{R_1} = \frac{(0.4636 \text{ A})(20.0 \Omega) - (9.00 \text{ V})}{10.0 \Omega} = 0.02727 \text{ A}$$

$$i_3 = -i_1 - i_2 = -(0.4636 \text{ A}) - (0.02727 \text{ A}) = -0.49087 \text{ A}, \text{ or } i_3 = 0.49087 \text{ A to the left.}$$

$$P_1 = (0.02727 \text{ A})^2 (10.0 \Omega) = 0.00744 \text{ W}, P_2 = (0.4636 \text{ A})^2 (20.0 \Omega) = 4.299 \text{ W}, \text{ and}$$

$$P_3 = (0.49087 \text{ A})^2 (30.0 \Omega) = 7.230 \text{ W}.$$

ROUND: $P_1 = 7.44 \text{ mW}$, $P_2 = 4.30 \text{ W}$ and $P_3 = 7.23 \text{ W}$.

DOUBLE-CHECK: Looking back at the values for current, it is found that

$$i_1 + i_2 + i_3 = 0.4636 \text{ A} + 0.02727 \text{ A} - 0.49087 \text{ A} = 0,$$

which is what would be expected. Going from left to right on each branch gives

$$-i_1 R_1 = -\frac{3.00}{11.0} \text{ V}, V_2 - i_2 R_2 = -\frac{3.00}{11.0} \text{ V} \text{ and } -i_3 R_3 - V_1 = -\frac{3.00}{11.0} \text{ V}.$$

So the potential drop across each branch in parallel is the same, so the answers make sense.

- 26.68. THINK:** From Kirchoff's rules, an equation can be obtained for the sum of the three currents, i_1 , i_2 and i_3 , and two equations can be obtained for the two inner loops of the circuit. This will yield 3 equations for 3 unknowns (the currents) and can be solved by substitution. Once the currents are known, the voltage drop over resistor 2 is found via Ohm's law. $R_1 = 30.0 \Omega$, $R_2 = 40.0 \Omega$, $R_3 = 20.0 \Omega$, $V_{\text{emf},1} = 12.0 \text{ V}$ and $V_{\text{emf},2} = 16.0 \text{ V}$.

SKETCH:

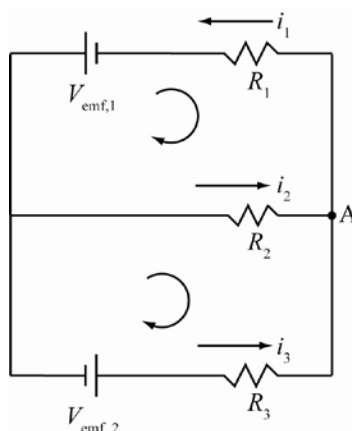

RESEARCH: By the choice of directions of currents, at point A, the currents sum as $i_1 - i_2 - i_3 = 0$. Going clockwise in the upper and lower loops gives 2 equations: $-V_1 + i_1 R_1 + i_2 R_2 = 0$ and $-i_2 R_2 + i_3 R_3 - V_2 = 0$. Potential drop across resistor 2 is $\Delta V = i_2 R_2$.

SIMPLIFY:

$$i_1 - i_2 - i_3 = 0 \Rightarrow i_3 = i_1 - i_2.$$

$$-V_1 + i_1 R_1 + i_2 R_2 = 0 \Rightarrow i_1 = \frac{V_1 - i_2 R_2}{R_1}$$

$$-i_2 R_2 + i_3 R_3 - V_2 = 0 \Rightarrow -i_2 R_2 + (i_1 - i_2) R_3 - V_2 = 0$$

$$\Rightarrow -i_2 R_2 + \left(\left(\frac{V_1 - i_2 R_2}{R_1} \right) - i_2 \right) R_3 - V_2 = 0 \Rightarrow i_2 = \frac{R_3 V_1}{R_1 R_2 + R_1 R_3 + R_2 R_3}$$

The potential drop across it is $\Delta V = |i_2| R_2$.

CALCULATE:

$$i_2 = \frac{R_3 V_1}{R_1 R_2 + R_1 R_3 + R_2 R_3} = \frac{(20.0 \Omega)(12.0 \text{ V})}{(30.0 \Omega)(40.0 \Omega) + (30.0 \Omega)(20.0 \Omega) + (40.0 \Omega)(20.0 \Omega)} = 0.092307 \text{ A}$$

$$\Delta V = (0.092307 \text{ A})(40.0 \Omega) = 3.6923 \text{ V}$$

ROUND: $\Delta V = 3.69 \text{ V}$

DOUBLE-CHECK: Going back to equation for i_1 and i_3 , I get $i_1 = 0.2769 \text{ A}$ and $i_3 = -0.18461 \text{ A}$, where $i_2 = 0.093207 \text{ A}$, so the currents are consistent. Calculating the potential drop across the upper and lower branches gives $V_1 - i_1 R_1 = 3.6923 \text{ V}$ and $V_2 + i_3 R_3 = 3.6923 \text{ V}$, so each branch has the same potential drop across it, so it makes sense.

- 26.69.** (a) From equation 24.10 of the textbook, the capacitance of a spherical capacitor is $C = \frac{4\pi\epsilon_0 ab}{b-a}$, where $b = 1.10 \text{ cm}$ and $a = 1.00 \text{ cm}$. Since it is connected in series with resistor $R = 10.0 \text{ M}\Omega$ and emf voltage, $V_{\text{emf}} = 10.0 \text{ V}$, the time constant is

$$\tau = RC = \frac{4\pi\epsilon_0 Rba}{(b-a)} = \frac{4\pi(8.8542 \cdot 10^{-12} \text{ N m}^2/\text{C}^2)(10.0 \text{ M}\Omega)(1.10 \text{ cm})(1.00 \text{ cm})}{(1.10 \text{ cm} - 1.00 \text{ cm})} = 1.22 \cdot 10^{-4} \text{ s}.$$

- (b) The charge on the capacitor still grows: $q(t) = q_0(1 - e^{-t/\tau})$, where $q_0 = CV_{\text{emf}}$. Therefore,

$$\begin{aligned} q(0.100 \text{ ms}) &= \frac{4\pi\epsilon_0 V_{\text{emf}} ba}{(b-a)} \left(1 - e^{-\frac{(0.1 \text{ ms})}{\tau}} \right) \\ &= \frac{4\pi(8.8542 \cdot 10^{-12} \text{ N m}^2/\text{C}^2)(10.0 \text{ V})(1.10 \text{ cm})(1.00 \text{ cm})}{(1.10 \text{ cm} - 1.00 \text{ cm})} \left(1 - e^{-\frac{(0.100 \text{ ms})}{(1.22 \cdot 10^{-4} \text{ s})}} \right) \\ &= 68.5 \text{ pC} \end{aligned}$$

- 26.70. THINK:** Since the circuit has three branches, four equations (one for each branch and the equation for the current at a junction) can be written down simply by inspection. However, a deeper analysis is required to fully understand the evolution of the circuit. For example, as the capacitor, $C = 30.0 \mu\text{F}$, charges, the current through it, $i_1(t)$, starts at some maximum and decays to zero. When this happens, the other currents, $i_2(t)$ and $i_3(t)$ must become equal. Even though there are two branches with batteries, $V_{\text{emf},2} = 80.0 \text{ V}$ and $V_{\text{emf},3} = 80.0 \text{ V}$, and resistors, $R_A = 40.0 \Omega$ and $R_B = 1.0 \Omega$, and $R_C = 20.0 \Omega$ and $R_D = 1.0 \Omega$, respectively, the capacitor effectively sees two resistors in parallel to charge through. All three currents and the potential across each branch are time dependent.

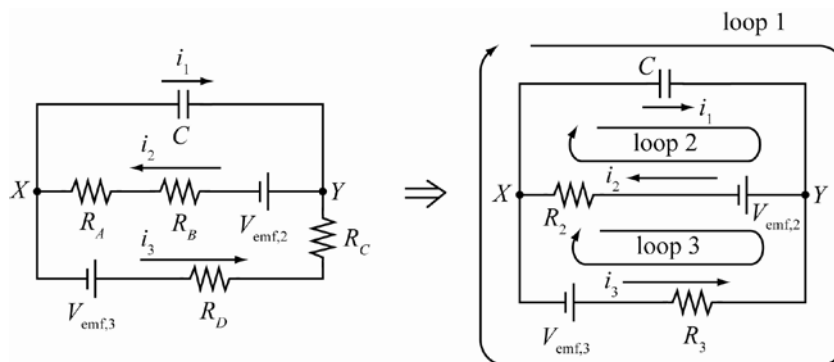
SKETCH:

RESEARCH: Starting at junction X and going clockwise around the three loops gives three equations for the potential along them. Also, junction X gives an equation relating the currents.

$$-\Delta V_C(t) + R_3 i_3(t) - V_{\text{emf},3} = 0 \quad (1)$$

$$-\Delta V_C(t) + V_{\text{emf},2} - R_2 i_2(t) = 0 \quad (2)$$

$$R_2 i_2(t) - V_{\text{emf},2} + R_3 i_3(t) - V_{\text{emf},3} = 0 \quad (3)$$

$$i_2(t) = i_1(t) + i_3(t) \quad (4)$$

where $R_2 = R_A + R_B$ and $R_3 = R_C + R_D$. The charge on the capacitor is $Q(t) = Q_{\text{max}}(1 - e^{-t/\tau})$, where $\tau = R_{\text{eq}} C$. The equivalent resistor is R_2 and R_3 in parallel. The current through the capacitor decays as $i_1(t) = i_1(0)e^{-t/\tau}$, where $i_1(0)$ is the initial current through the capacitor.

SIMPLIFY: The time constant is given by: $\tau = R_{\text{eq}} C = C \left(\frac{1}{R_2} + \frac{1}{R_3} \right)^{-1} = \frac{CR_2 R_3}{R_2 + R_3}$. Consider the voltage drop

from junction X to Y . Along each branch it must be equal, so for the bottom two branches: $R_2 i_2(t) - V_{\text{emf},2} = V_{\text{emf},3} - R_3 i_3(t) \Rightarrow V_{\text{emf},3} + V_{\text{emf},2} = R_2 i_2(t) + R_3 i_3(t)$. Using equation (4), and substituting in for $i_2(t)$ and $i_3(t)$ gives:

$$V_{\text{emf},2} + V_{\text{emf},3} = R_2 [i_1(t) + i_3(t)] + R_3 i_3(t) = R_2 i_1(t) + (R_2 + R_3) i_3(t) \Rightarrow i_3(t) = \frac{V_{\text{emf},2} + V_{\text{emf},3} - R_2 i_1(t)}{R_2 + R_3},$$

$$V_{\text{emf},2} + V_{\text{emf},3} = R_2 i_2(t) + R_3 [i_2(t) - i_1(t)] = -R_3 i_1(t) + (R_2 + R_3) i_2(t) \Rightarrow i_2(t) = \frac{V_{\text{emf},2} + V_{\text{emf},3} + R_3 i_1(t)}{R_2 + R_3}.$$

When $t \rightarrow \infty$, $i_1(t) \rightarrow 0$, so the steady state current is given by: $\lim_{t \rightarrow \infty} i_2(t) = \lim_{t \rightarrow \infty} i_3(t) = i_s = \frac{V_{\text{emf},2} + V_{\text{emf},3}}{R_2 + R_3}$.

At all times, the voltage drop from X to Y is the same along any branch. Now that the steady state current is reached, the voltage drop across the capacitor can be determined and thus the maximum charge and initial current on the capacitor. Compare $\Delta V_C(t = \infty)$ to both branches:

$$\Delta V_C(t = \infty) = \Delta V_{C,\text{max}} = R_3 i_3(t = \infty) - V_{\text{emf},3} = R_3 i_s - V_{\text{emf},3} \quad \text{or}$$

$$\Delta V_{C,\text{max}} = V_{\text{emf},2} - R_2 i_2(t = \infty) = V_{\text{emf},2} - R_2 i_s.$$

$$\begin{aligned}
 \Rightarrow \Delta V_{C,\max} &= R_3 \left(\frac{V_{\text{emf},2} + V_{\text{emf},3}}{R_2 + R_3} \right) - V_{\text{emf},3} = V_{\text{emf},2} - R_2 \left(\frac{V_{\text{emf},2} + V_{\text{emf},3}}{R_2 + R_3} \right) \\
 \Rightarrow R_3 \left(\frac{V_{\text{emf},2} + V_{\text{emf},3}}{R_2 + R_3} \right) - V_{\text{emf},3} \left(\frac{R_2 + R_3}{R_2 + R_3} \right) &= V_{\text{emf},2} \left(\frac{R_2 + R_3}{R_2 + R_3} \right) - R_2 \left(\frac{V_{\text{emf},2} + V_{\text{emf},3}}{R_2 + R_3} \right) \\
 \Rightarrow \frac{R_3 V_{\text{emf},2} - R_2 V_{\text{emf},3}}{R_2 + R_3} &= \frac{R_3 V_{\text{emf},2} - R_2 V_{\text{emf},3}}{R_2 + R_3}.
 \end{aligned}$$

The maximum charge is given by: $Q_{\max} = C\Delta V_{C,\max} = \frac{C(R_3 V_{\text{emf},2} - R_2 V_{\text{emf},3})}{R_2 + R_3}$. In general, $Q(t)$ is related to

$$i_1(t) \text{ by: } i_1(t) = \frac{dQ(t)}{dt} = \frac{d}{dt} Q_{\max} (1 - e^{-t/\tau}) = Q_{\max} \left(0 - -\frac{1}{\tau} e^{-t/\tau} \right) = \frac{Q_{\max}}{\tau} e^{-t/\tau}.$$

$$i_1(0) = \frac{Q_{\max}}{\tau} = \frac{C(R_3 V_{\text{emf},2} - R_2 V_{\text{emf},3})}{R_2 + R_3} \left(\frac{R_2 + R_3}{CR_2 R_3} \right) = \frac{V_{\text{emf},2}}{R_2} - \frac{V_{\text{emf},3}}{R_3}$$

Now that $i_1(0)$ is determined, $i_2(t)$ and $i_3(t)$ can be expressed in simpler terms:

$$\begin{aligned}
 i_2(t) &= \frac{V_{\text{emf},2} + V_{\text{emf},3} + R_3 i_1(t)}{R_2 + R_3} = \frac{V_{\text{emf},2} + V_{\text{emf},3}}{R_2 + R_3} + \frac{R_3 (V_{\text{emf},2} / R_2 - V_{\text{emf},3} / R_3) e^{-t/\tau}}{R_2 + R_3} \\
 &= i_s + \left[\frac{(R_3 / R_2) V_{\text{emf},2} - V_{\text{emf},3}}{R_2 + R_3} \right] e^{-t/\tau}.
 \end{aligned}$$

$$\begin{aligned}
 i_3(t) &= \frac{V_{\text{emf},2} + V_{\text{emf},3} - R_2 i_1(t)}{R_2 + R_3} = \frac{V_{\text{emf},2} + V_{\text{emf},3}}{R_2 + R_3} - \frac{R_2 (V_{\text{emf},2} / R_2 - V_{\text{emf},3} / R_3) e^{-t/\tau}}{R_2 + R_3} \\
 &= i_s + \left[\frac{(R_2 / R_3) V_{\text{emf},3} - V_{\text{emf},2}}{R_2 + R_3} \right] e^{-t/\tau}
 \end{aligned}$$

The potential across the capacitor for any given times is then given by:

$$\Delta V_C(t) = \frac{Q(t)}{C} = \frac{Q_{\max}}{C} (1 - e^{-t/\tau}) = \frac{R_3 V_{\text{emf},2} - R_2 V_{\text{emf},3}}{R_2 + R_3} (1 - e^{-t/\tau}).$$

Therefore, in addition to the previous four equations, there are six additional ones.

$$\tau = \frac{CR_2 R_3}{R_2 + R_3} \quad (5)$$

$$i_s = \frac{V_{\text{emf},2} + V_{\text{emf},3}}{R_2 + R_3} \quad (6)$$

$$i_1(t) = \left(\frac{V_{\text{emf},2}}{R_2} - \frac{V_{\text{emf},3}}{R_3} \right) e^{-t/\tau} \quad (7)$$

$$i_2(t) = i_s + \left[\frac{(R_3 / R_2) V_{\text{emf},2} - V_{\text{emf},3}}{R_2 + R_3} \right] e^{-t/\tau} \quad (8)$$

$$i_3(t) = i_s + \left[\frac{(R_2 / R_3) V_{\text{emf},3} - V_{\text{emf},2}}{R_2 + R_3} \right] e^{-t/\tau} \quad (9)$$

$$\Delta V_C(t) = \frac{R_3 V_{\text{emf},2} - R_2 V_{\text{emf},3}}{R_2 + R_3} (1 - e^{-t/\tau}) \quad (10)$$

CALCULATE: $R_1 = 40.0 \, \Omega + 1.0 \, \Omega = 41.0 \, \Omega$, $R_2 = 20.0 \, \Omega + 1.0 \, \Omega = 21.0 \, \Omega$

$$\tau^{-1} = \left[\frac{(30.0 \, \mu\text{F})(41.0 \, \Omega)(21.0 \, \Omega)}{41.0 \, \Omega + 21.0 \, \Omega} \right]^{-1} = (4.16613 \cdot 10^{-4} \, \text{s})^{-1} = 2400.31 \, \text{s}^{-1}$$

$$i_s = \frac{80.0 \, \text{V} + 80.0 \, \text{V}}{41.0 \, \Omega + 21.0 \, \Omega} = 2.580645161 \, \text{A}, \quad \frac{V_{\text{emf},2}}{R_2} - \frac{V_{\text{emf},3}}{R_3} = \frac{80.0 \, \text{V}}{41.0 \, \Omega} - \frac{80.0 \, \text{V}}{21.0 \, \Omega} = -1.858304297 \, \text{A}$$

$$\frac{(R_3 / R_2)V_{\text{emf},2} - V_{\text{emf},3}}{R_2 + R_3} = \frac{(21.0 \, \Omega / 41.0 \, \Omega)80.0 \, \text{V} - 80.0 \, \text{V}}{21.0 \, \Omega + 41.0 \, \Omega} = -0.6294256 \, \text{A}$$

$$\frac{(R_2 / R_3)V_{\text{emf},3} - V_{\text{emf},2}}{R_2 + R_3} = \frac{(41.0 \, \Omega / 21.0 \, \Omega)80.0 \, \text{V} - 80.0 \, \text{V}}{21.0 \, \Omega + 41.0 \, \Omega} = 1.228878648 \, \text{A}$$

$$\frac{R_3 V_{\text{emf},2} - R_2 V_{\text{emf},3}}{R_2 + R_3} = \frac{21.0 \, \Omega(80.0 \, \text{V}) - 41.0 \, \Omega(80.0 \, \text{V})}{21.0 \, \Omega + 41.0 \, \Omega} = -25.8069516 \, \text{V}$$

ROUND: The initial four equations, rounded to three significant figures are:

$$(1) 79.98 \, \text{V} + (0.03 \, \text{V})e^{-(2400 \, \text{s}^{-1})t} - 80.0 \, \text{V} = 0, \quad (2) 80.0 \, \text{V} - \left[79.98 \, \text{V} + (0.011 \, \text{V})e^{-(2400 \, \text{s}^{-1})t} \right] = 0,$$

$$(3) 159.96 \, \text{V} + (0.041 \, \text{V})e^{-(2400 \, \text{s}^{-1})t} - 160.0 \, \text{V} = 0 \quad \text{and}$$

$$(-0.629 \, \text{A})e^{-(2400 \, \text{s}^{-1})t} = (-1.86 \, \text{A})e^{-(2400 \, \text{s}^{-1})t} + (1.23 \, \text{A})e^{-(2400 \, \text{s}^{-1})t}.$$

DOUBLE-CHECK: The initial four equations within rounding are still valid, so the values of the coefficients are correct. Checking $i_2(0)$ and $i_3(0)$ using equations (8) and (9) gives:

$$i_2(0) = \frac{V_{\text{emf},2} + V_{\text{emf},3} + R_3(V_{\text{emf},2}/R_2 - V_{\text{emf},3}/R_3)}{R_2 + R_3} = \frac{V_{\text{emf},2}(1 + R_3/R_2)}{R_2(1 + R_3/R_2)} = \frac{V_{\text{emf},2}}{R_2} \quad \text{and}$$

$$i_3(0) = \frac{V_{\text{emf},2} + \Delta V_3 - R_2(V_{\text{emf},2}/R_2 - V_{\text{emf},3}/R_3)}{R_2 + R_3} = \frac{V_{\text{emf},3}(1 + R_2/R_3)}{R_3(1 + R_2/R_3)} = \frac{V_{\text{emf},3}}{R_3}.$$

These results satisfy $i_1(0) = i_2(0) - i_3(0) = (V_{\text{emf},2}/R_2) - (V_{\text{emf},3}/R_3)$. Also, consider that initially the $V_{\text{emf},2}$ battery “sees” only R_2 first (likewise for battery $V_{\text{emf},3}$ and R_3), so the initial current is simply $V_{\text{emf},2}/R_2$ (or $V_{\text{emf},3}/R_3$), so the equations for the currents make sense.

- 26.71. THINK:** The capacitor of capacitance is $C = 10.0 \, \mu\text{F}$, is charged through a resistor of resistance $R = 10.0 \, \Omega$, with a battery, $V_{\text{emf}} = 10.0 \, \text{V}$. It is discharged through a resistor, $R' = 1.00 \, \Omega$. For either charging or discharging, it takes the same number of time constants to get to half of the maximum value. The energy on the capacitor is proportional to the square of the charge.

SKETCH:

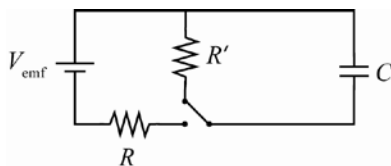

RESEARCH: The capacitor’s charge is given by $q(t) = q_0(1 - e^{-t/\tau})$. In general, the energy on the capacitor is given by $E(t) = q^2(t)/2C$. The time constant is either $\tau = RC$ or $\tau' = R'C$.

SIMPLIFY:

$$(a) \text{ When } q(t) = q_0/2, \text{ then: } q(t) = \frac{1}{2}q_0 = q_0(1 - e^{-t/\tau}) \Rightarrow \frac{1}{2} = 1 - e^{-t/\tau} \Rightarrow t = -\tau \ln\left(\frac{1}{2}\right) = \tau \ln 2.$$

(b) If $q(t) = \frac{1}{2}q_0$, the energy is: $E(t) = \frac{q^2(t)}{2C} = \frac{(q_0/2)^2}{2C} = \frac{1}{4} \left(\frac{q_0^2}{2C} \right) = \frac{1}{4} E_{\max}$.

(c) The time constant for discharging is $\tau' = R'C$.

(d) The capacitor discharges to half the original charge in $t = \tau' \ln(2)$.

CALCULATE:

(a) $t = \tau \ln 2.00$, or $(0.693)\tau$

(b) 1.00:4.00.

(c) $\tau' = (1.00 \Omega)(10.0 \times 10^{-6} \text{ F}) = 10.0 \mu\text{s}$

(d) $t = (10.0 \mu\text{s}) \ln(2.00) = 6.93 \mu\text{s}$

ROUND:

(a) 0.693τ

(b) 1.00:4.00.

(c) $\tau' = 10.0 \mu\text{s}$

(d) $t = 6.93 \mu\text{s}$

DOUBLE-CHECK: In general, charge decreases exponentially as $q(t) = q_0 e^{-t/\tau}$. For $\tau' = 10 \mu\text{s}$ and $t = 6.93 \mu\text{s}$, the charge is $q(6.93 \mu\text{s}) = q_0 e^{-6.93/10} = 0.497q_0$, which is about half the original charge.

26.72. THINK: From Kirchoff's rules, an equation can be obtained for the sum of the three currents, i_1 , i_2 and i_3 , and two equations can be obtained for the two inner loops of the circuit. This will yield 3 equations for 3 unknowns (the currents) and can be solved by simple substitution. Once the currents are known, the voltage drop over resistor 2 is found via Ohm's law. $R_1 = 3.00 \Omega$, $R_2 = 2.00 \Omega$, $R_3 = 5.00 \Omega$, $V_{\text{emf},1} = 10.0 \text{ V}$ and $V_{\text{emf},2} = 6.00 \text{ V}$.

SKETCH:

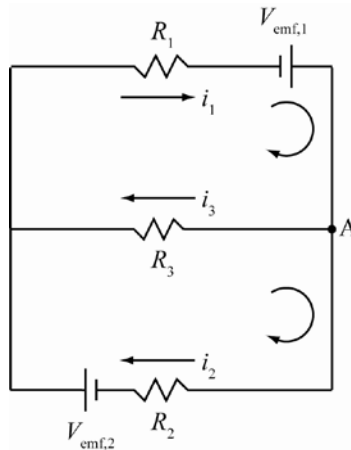

RESEARCH: By the choice of directions of currents, at point A, the currents sum as $i_1 - i_2 - i_3 = 0$. Going clockwise in the upper and lower loops gives 2 equations: $-i_1 R_1 + V_{\text{emf},1} - i_3 R_3 = 0$ and $i_3 R_3 - i_2 R_2 + V_{\text{emf},2} = 0$. Potential drop across resistor 2 is $\Delta V = i_2 R_2$. The power across the third resistor is $P = i_3^2 R_3$.

SIMPLIFY: From equation of currents: $i_1 = i_2 + i_3 \Rightarrow i_3 = i_1 - i_2$. From the upper loop: $V_{\text{emf},1} - i_3 R_3 = i_1 R_1 \Rightarrow i_1 = (V_{\text{emf},1} / R_1) - (i_3 R_3 / R_1)$. From the lower loop: $V_{\text{emf},2} + i_3 R_3 = i_2 R_2 \Rightarrow i_2 = (V_{\text{emf},2} / R_2) + (i_3 R_3 / R_2)$. Therefore,

$$\begin{aligned}
 i_3 = i_1 - i_2 &= \frac{V_{\text{emf},1}}{R_1} - i_3 \frac{R_3}{R_1} - \frac{V_{\text{emf},2}}{R_2} - i_3 \frac{R_3}{R_2} \Rightarrow \frac{R_3}{R_3} i_3 = \frac{V_{\text{emf},1}}{R_1} - \frac{V_{\text{emf},2}}{R_2} - i_3 \left(\frac{R_3}{R_1} + \frac{R_3}{R_2} \right) \\
 \Rightarrow i_3 \left(\frac{R_3}{R_3} + \frac{R_3}{R_1} + \frac{R_3}{R_2} \right) &= \frac{V_{\text{emf},1}}{R_1} - \frac{V_{\text{emf},2}}{R_2} \Rightarrow i_3 = \left(\frac{V_{\text{emf},1}}{R_1} - \frac{V_{\text{emf},2}}{R_2} \right) \left(\frac{R_3}{R_3} + \frac{R_3}{R_1} + \frac{R_3}{R_2} \right)^{-1} \\
 \Rightarrow i_3 &= \left[\left(\frac{V_{\text{emf},1}}{R_1 R_3} \right) - \left(\frac{V_{\text{emf},2}}{R_2 R_3} \right) \right] \left(\frac{1}{R_3} + \frac{1}{R_1} + \frac{1}{R_2} \right)^{-1}
 \end{aligned}$$

CALCULATE:

$$(a) \quad i_3 = \left[\frac{10.0 \text{ V}}{(3.00 \, \Omega)(5.00 \, \Omega)} - \frac{6.00 \text{ V}}{(2.00 \, \Omega)(5.00 \, \Omega)} \right] \left(\frac{1}{5.00 \, \Omega} + \frac{1}{3.00 \, \Omega} + \frac{1}{2.00 \, \Omega} \right)^{-1} = 0.06452 \text{ A}$$

$$(b) \quad P = (0.06452 \text{ A})^2 (5.00 \, \Omega) = 0.02081 \text{ W}$$

ROUND:

$$(a) \quad i = 64.5 \text{ mA}$$

$$(b) \quad P = 20.8 \text{ mW}$$

DOUBLE-CHECK: Going back to equation for i_1 and i_2 , the currents can be calculated as $i_1 = 3.2258 \text{ A}$ and $i_2 = 3.1613 \text{ A}$. Their difference is $i_1 - i_2 = 0.0645 \text{ A}$, which is also i_3 ; therefore, the current is correct and it makes sense.

- 26.73. THINK:** From Kirchhoff's rules, an equation can be obtained for the sum of the five currents, i_1 , i_2 , i_3 , i_4 and i_5 , and two equations can be obtained for the two inner loops of the circuit. Since the voltage drop across resistor 3 is zero, the current through that branch is also zero. Ohm's law allows an equation for the ratios of the resistors. Once R_2 is known, the current through it is obtained by equation the potential drop across both R_1 and R_2 is equal to the emf voltage. $R_1 = 8.00 \, \Omega$, $R_4 = 2.00 \, \Omega$, $R_5 = 6.00 \, \Omega$ and $V_{\text{emf}} = 15.0 \text{ V}$.

SKETCH:

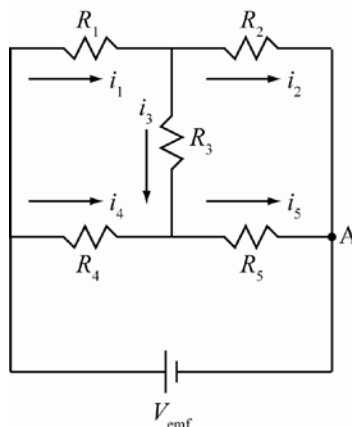

RESEARCH: By the choice of directions of currents, two equations arise $i_1 = i_2 + i_3$ and $i_5 = i_3 + i_4$. Since the current through R_3 is zero, $\Delta V_3 = i_3 R_3 = 0$. Then, two sets of potential drops are equal: $i_1 R_1 = i_4 R_4$ and $i_2 R_2 = i_5 R_5$. The potential across R_1 and R_2 is $V_{\text{emf}} = i_1 R_1 + i_2 R_2$.

SIMPLIFY: Since i_3 is zero, the current becomes $i_1 = i_2$ and $i_4 = i_5$. Dividing the potential drops across each resistors yields

$$\frac{i_1 R_1}{i_2 R_2} = \frac{i_4 R_4}{i_5 R_5} \Rightarrow \frac{R_1}{R_2} = \frac{R_4}{R_5} \Rightarrow R_2 = \frac{R_1 R_5}{R_4}$$

The current through it is $i_2 = i_1 = i$; therefore, $V_{\text{emf}} = i_1 (R_1 + R_2) \Rightarrow i_1 = V_{\text{emf}} / (R_1 + R_2)$.

CALCULATE: $R_2 = \frac{(8.00 \Omega)(6.00 \Omega)}{2.00 \Omega} = 24.0 \Omega$, $i_2 = i_1 = \frac{15.0 \text{ V}}{8.00 \Omega + 240 \Omega} = 0.46875 \text{ A}$

ROUND: $R_2 = 24.0 \Omega$, $i_2 = 469 \text{ mA}$

DOUBLE-CHECK: Solving for $i_4 = i_5 = V_{\text{emp}} / (R_u + R_s) = 1.875 \text{ A}$ for a total current of $i_T = 2.34375 \text{ A}$ coming out of the battery. Since there is no current in R_3 , the circuit is just R_1 and R_2 in parallel with R_4 and R_5 to gives $R_{\text{eq}} = [1/(R_1 + R_2) + 1/(R_4 + R_5)]^{-1}$, and produces a current of $i = \Delta V_{\text{emp}} / R_{\text{eq}} = 2.34375 = i_T$, so it makes sense.

- 26.74. THINK:** From Kirchhoff's rules, equations can be obtained for the sum of the five currents, i_1 , i_2 , i_3 , i_4 and i_5 , and three equations for the three inner loops of the circuit. This will yield 5 equations and 4 unknowns (the currents) and can be solved by simple substitution. $R_1 = 1.00 \Omega$, $R_2 = 2.00 \Omega$, $R_3 = 3.00 \Omega$, $R_4 = 4.00 \Omega$, $R_5 = 5.00 \Omega$, $V_{\text{emf},1} = 12.0 \text{ V}$ and $V_{\text{emf},2} = 6.00 \text{ V}$.

SKETCH:

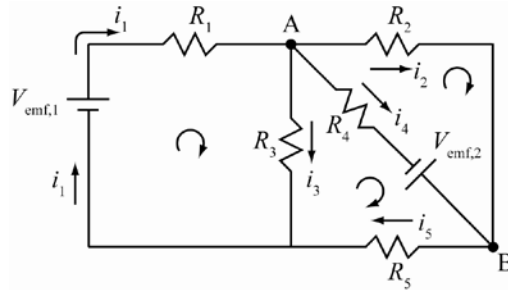

RESEARCH: By the choice of directions of currents, at point A, $i_1 - i_2 - i_3 - i_4 = 0$, and at point B, $i_2 + i_4 - i_5 = 0$. By going clockwise in each loop yields 3 equations: $V_{\text{emf},1} - i_1 R_1 - i_3 R_3 = 0$, $-i_2 R_2 - V_{\text{emf},2} - i_4 R_4 = 0$ and $-i_4 R_4 + V_{\text{emf},2} - i_5 R_5 + i_3 R_3 = 0$. Potential drop across resistor 2 is $\Delta V = i_2 R_2$. The power across the third resistor is $P = i_3^2 R_3$.

SIMPLIFY:

- (a) Using the equation $i_5 = i_2 + i_4$, the other 4 can be simplified to: 1) $i_1 - i_2 - i_3 - i_4 = 0$; 2) $R_1 i_1 + R_3 i_3 = V_{\text{emf},1}$; 3) $-R_2 i_2 + R_4 i_4 = V_{\text{emf},2}$; 4) $R_5 i_2 - R_3 i_3 + (R_4 + R_5) i_4 = V_{\text{emf},2}$.
 (b) Since the resistance are in Ω and all voltages are in V, the equations can be rewritten for simplicity with only the magnitude of the values, knowing that the final currents are in A, which yields: 1) $i_1 - i_2 - i_3 - i_4 = 0$; 2) $i_1 + 3i_3 = 12.0$; 3) $-2i_2 + 4i_4 = 6.00$; 4) $5i_2 - 3i_3 + 9i_4 = 6.00$.

$$\begin{aligned} (2)-(1): i_2 + 4i_3 + i_4 &= 12.0 \equiv (2A) \\ 2(2A)+(3) : 8i_3 + 6i_4 &= 30.0 \equiv (3A) \\ -5(2A)+(4) : -23i_3 + 4i_4 &= -54.0 \equiv (4A) \\ (23/8)(2A)+(4A) : (85.0/4)i_4 &= 32.25 \equiv (4B). \end{aligned}$$

Therefore, $(4B) \Rightarrow i_4 = 129/85.0$, $(3A) \Rightarrow i_3 = (30.0 - 6i_4)/8 = 222/85.0$,

$(2A) \Rightarrow i_2 = 12.0 - 4i_3 - i_4 = 3.00/85.0$, and $(1) \Rightarrow i_1 = i_2 + i_3 + i_4 = 354/85.0$.

CALCULATE: $i_4 = \frac{129}{85.0} \text{ A} = 1.5176 \text{ A}$

ROUND: $i_4 = 1.52 \text{ A}$

DOUBLE-CHECK: If these currents are used to calculate the potential drop from $A \rightarrow B$, you get $-i_3 R_3 + i_5 R_5 = 0.071 \text{ V}$, $-i_4 R_4 + \Delta V_2 = 0.071 \text{ V}$, and $-i_2 R_2 = 0.071 \text{ V}$, so the potential drops are all the same, so it makes sense.

- 26.75. **THINK:** Consider any square on the grid to have been reduced so that every side has a capacitance, C' , which is the equivalent of all the capacitors above, below and along each side. Since the grid is infinite, then no side has more capacitors than any other, so all four are reduced to the same capacitance. Next, consider the same analysis except for only three sides, so that one side is still of capacitance, C , while the others are C' . When those four sides are reduced to one equivalent capacitance, the result should be equal to the original value of C' . This is because the grid is infinite and adding an extra square to the already reduced side should affect nothing, resulting in the same capacitance, giving a recursive relation in C , and thus the total equivalent capacitance, in terms of C , can be determined.

SKETCH:

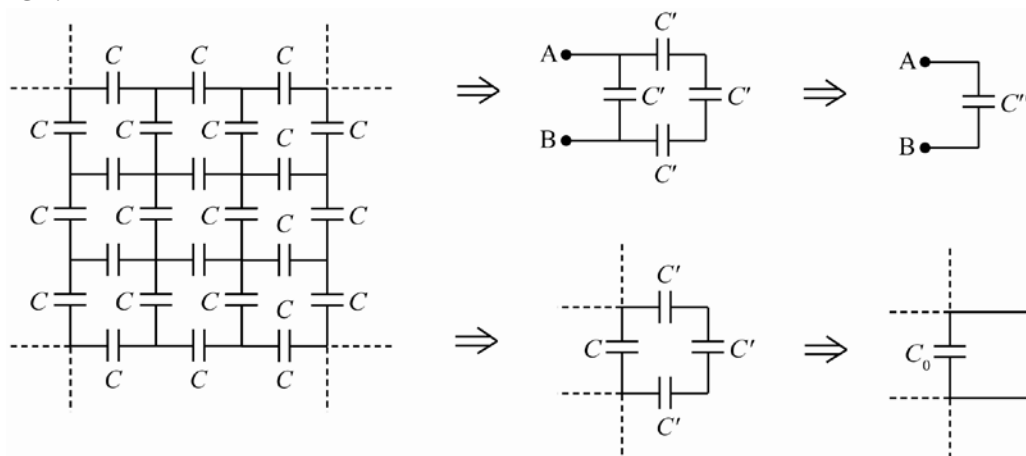

RESEARCH: Capacitors in series add as $C_{\text{eq}}^{-1} = C_1^{-1} + C_2^{-1}$. Capacitors in parallel add as $C_{\text{eq}} = C_1 + C_2$.

SIMPLIFY: When all four sides are reduced to C' , the equivalent capacitance (across A to B) is:

$$C'' = C' + \left(\frac{1}{C'} + \frac{1}{C'} + \frac{1}{C'} \right)^{-1} = \frac{4C'}{3}.$$

Looking at when one side is reduced using the other three reduced gives C_0 as:

$$C_0 = C + \left(\frac{1}{C'} + \frac{1}{C'} + \frac{1}{C'} \right)^{-1} = C + \frac{C'}{3}.$$

Since $C_0 = C'$: $C' = C + \frac{C'}{3} \Rightarrow C = \frac{2}{3}C'$ and $C' = \frac{3}{2}C$. Therefore, the total equivalent capacitance is:

$$C'' = \frac{4C'}{3} = \frac{4}{3} \left(\frac{3}{2}C \right) = \frac{4}{2}C = 2C.$$

CALCULATE: Not applicable.

ROUND: Not applicable.

DOUBLE-CHECK: Consider an intersection on the grid. If a voltage was applied to this point, it would see equal capacitance (since it is infinite) in all four directions, meaning it would contribute an equal charge, q , to each direction. If the same voltage with opposite polarity was applied to any adjacent intersection, it would see a $-q$ along each direction. This means the capacitor that joins the two intersections is actually double the charge on one, meaning the potential sees an effective capacitance twice the size of any one capacitor, so an equivalent capacitance of $2C$ is correct. $C_0 = C + C'/3 \Rightarrow C' = (3/2)C$. Therefore the total equivalent capacitance is $C'' = (4/3)C' = (4/3)(3/2)C = 2C$.

Multi-Version Exercises

Exercises 26.76–26.78 Using Kirchhoff's Loop Rule we get $-iR_i - V_t + V_e = 0$. So the required battery charger emf is $V_e = iR_i + V_t$.

$$26.76. \quad V_e = iR_i + V_t = (9.759 \text{ A})(0.1373 \Omega) + 11.45 \text{ V} = 12.79 \text{ V}$$

26.77. The potential difference across the terminals during charging is equal to the charger emf, 14.51 V. To find the open-circuit potential difference across the terminals, with the charger removed and no voltage drop due to internal resistance, use $V_e = iR_i + V_t$.

$$V_t = V_e - iR_i = 14.51 \text{ V} - (5.399 \text{ A})(0.1415 \Omega) = 13.75 \text{ V}$$

$$26.78. \quad V_e = iR_i + V_t$$

$$R_i = \frac{V_e - V_t}{i} = \frac{16.93 \text{ V} - 16.05 \text{ V}}{6.041 \text{ A}} = 0.15 \Omega$$

Note that by the subtraction rule, the difference of the two voltages has only two significant figures.

Exercises 26.79–26.81 Kirchhoff's Loop Rule gives us

$$V_{\text{emf},1} - \Delta V_1 - \Delta V_2 - V_{\text{emf},2} = V_{\text{emf},1} - iR_1 - iR_2 - V_{\text{emf},2} = 0.$$

We can rearrange this equation to get

$$V_{\text{emf},1} - i(R_1 + R_2) - V_{\text{emf},2} = 0$$

$$i = \frac{V_{\text{emf},1} - V_{\text{emf},2}}{R_1 + R_2}.$$

$$26.79. \quad i = \frac{V_{\text{emf},1} - V_{\text{emf},2}}{R_1 + R_2} = \frac{21.01 \text{ V} - 10.75 \text{ V}}{23.37 \Omega + 11.61 \Omega} = 0.2933 \text{ A}$$

$$26.80. \quad i = \frac{V_{\text{emf},1} - V_{\text{emf},2}}{R_1 + R_2}$$

$$R_2 = \frac{V_{\text{emf},1} - V_{\text{emf},2}}{i} - R_1 = \frac{16.37 \text{ V} - 10.81 \text{ V}}{0.1600 \text{ A}} - 24.65 \Omega = 10.10 \Omega.$$

$$26.81. \quad i = \frac{V_{\text{emf},1} - V_{\text{emf},2}}{R_1 + R_2}$$

$$i(R_1 + R_2) = V_{\text{emf},1} - V_{\text{emf},2}$$

$$V_{\text{emf},2} = V_{\text{emf},1} - i(R_1 + R_2) = 17.75 \text{ V} - (0.1740 \text{ A})(25.95 \Omega + 13.59 \Omega) = 10.87 \text{ V}$$

Exercises 26.82–26.84 When the resistor is connected to the charged capacitor, the initial current i_0 will be given by $V_{\text{emf}} = i_0 R \Rightarrow i_0 = \frac{V_{\text{emf}}}{R}$. The time constant is $\tau = RC$. The current after time t is

$$i = i_0 e^{-t/\tau} = \frac{V_{\text{emf}}}{R} e^{-t/(RC)}.$$

$$26.82. \quad i = \frac{V_{\text{emf}}}{R} e^{-t/(RC)} = \frac{131.1 \text{ V}}{616.5 \Omega} e^{-(3.871 \text{ s})/((616.5 \Omega)(15.19 \cdot 10^{-3} \text{ F}))} = 0.1407 \text{ A}$$

$$26.83. \quad i = \frac{V_{\text{emf}}}{R} e^{-t/(RC)}$$

$$\frac{iR}{V_{\text{emf}}} = e^{-t/(RC)}$$

$$\ln\left(\frac{iR}{V_{\text{emf}}}\right) = -t/(RC)$$

$$C = -\frac{t}{R \ln\left(\frac{iR}{V_{\text{emf}}}\right)} = -\frac{1.743 \text{ s}}{(655.1 \, \Omega) \ln\left(\frac{(0.1745 \text{ A})(655.1 \, \Omega)}{133.1 \text{ V}}\right)} = 0.01749 \text{ F} = 17.49 \text{ mF}$$

$$26.84. \quad i = \frac{V_{\text{emf}}}{R} e^{-t/(RC)}$$

$$V_{\text{emf}} = iR e^{t/(RC)} = (0.1203 \text{ A})(693.5 \, \Omega) e^{(6.615 \text{ s})/((693.5 \, \Omega)(19.79 \cdot 10^{-3} \text{ F}))} = 135.1 \text{ V}$$

Chapter 27: Magnetism

Concept Checks

27.1. a 27.2. a 27.3. c 27.4. a 27.5. a

Multiple-Choice Questions

27.1. b 27.2. c 27.3. e 27.4. b 27.5. a 27.6. a 27.7. a,c,d,e are true; b is false 27.8. b 27.9. e 27.10. d 27.11. d 27.12. d

Conceptual Questions

27.13. (a)

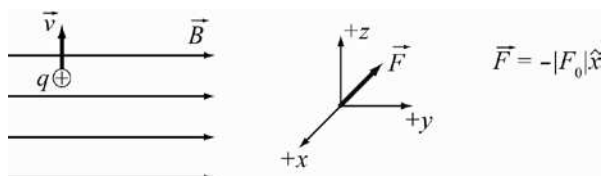

(b)

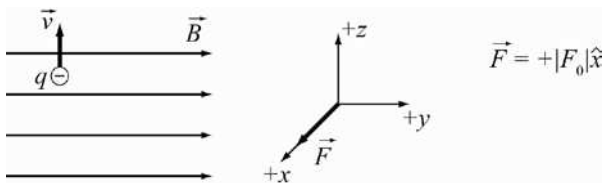

(c)

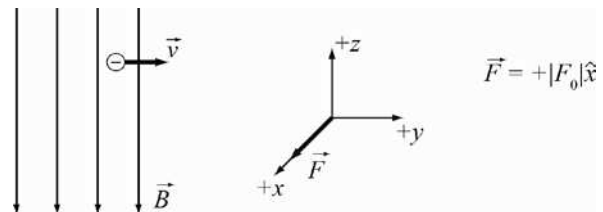

(d)

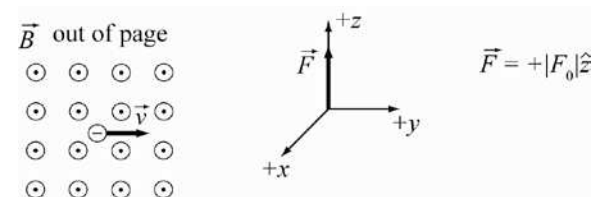

27.14. Zero. The force acting on a charged particle in a magnetic field is $\vec{F} = q\vec{v} \times \vec{B}$. By definition of the cross-product (and confirmed by experiment), this force is always perpendicular to the velocity of the particle at any point in the magnetic field. Thus, the work done by the magnetic field on the charged particle is zero. The effect of this force on the particle is that it changes the direction of the particle's velocity, but not its magnitude. Hence, the uniform circular motion the particle has in the magnetic field (the cyclotron motion).

27.15. $A =$ Parabolic (electric field). $B =$ Circular (magnetic field). The forces acting on a charged particle under either an electric field or a magnetic field is $\vec{F} = q\vec{E}$ or $\vec{F} = q\vec{v} \times \vec{B}$, respectively.

27.16.



(a) The direction of the force acting on a charge moving in a magnetic field is given by the right-hand rule. If the fingers point in the direction of \vec{v} , then to produce a force in the negative x -direction, the magnetic field has to act out of the page, in positive z -direction.

(b) Yes, it does change. For the negatively charged electron, the field must point into the page, in negative z -direction. The direction of the force depends on the charge.

27.17. A magnetic potential is used to represent magnetic fields in regions of zero current density in some applications, but the construction is not as useful as its electrical counterpart. This is because the electric potential represents a potential energy (per unit charge), which is part of a conserved total energy. It keeps track of the work done by the electric field on a charge moving in that field, and can thus be used to analyze the dynamics of charged particles. But the magnetic field never does any work on a charged particle, as the magnetic force is perpendicular to the particle's velocity. There is no work for a magnetic scalar potential energy to track. It represents no contribution to a conserved total energy, and hence, does not enter into any dynamics. It is more useful in advanced treatments of electromagnetic theory to represent the magnetic field as the curl of a vector potential: $\vec{B} = \nabla \times \vec{A}$, for a suitable vector field, \vec{A} .

27.18. This is possible if the direction of the current is parallel or anti-parallel to that of the magnetic field. In such a case, $d\vec{F} = i d\vec{L} \times \vec{B} = 0$.

27.19. Yes, it is possible. In order for this to work, the force due to the electric field, $\vec{F} = q\vec{E}$, has to be perpendicular to the velocity vector at all times. One way to achieve this is to have the electric field from a point particle, say a proton, for which the electric field points in radial outwards direction. An electron with suitable initial velocity can then make circular orbits around the proton. For these the speed does not change. If the electric field is replaced with a uniform magnetic field, the speed of a charged particle never changes. Note that in both cases described here, only the speed is constant, but the *direction* of the velocity vector changes. (In the case that the initial velocity vector is parallel or anti-parallel to the magnetic field even the direction stays constant.)

27.20. The charged particle will move in a helix around the magnetic field lines. Its motion in the z -direction is unaffected by the magnetic field, and therefore the time required involves determining the component of the initial velocity in the z -direction, which is simply v multiplied by the cosine of the angle. Thus, the time

required is $\Delta t = \frac{\Delta z}{v_z} = \frac{\Delta z}{v \cos \theta}$, where Δz is the extent of the region along the z -direction.

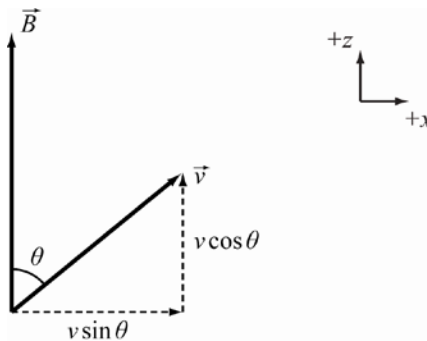

27.21.

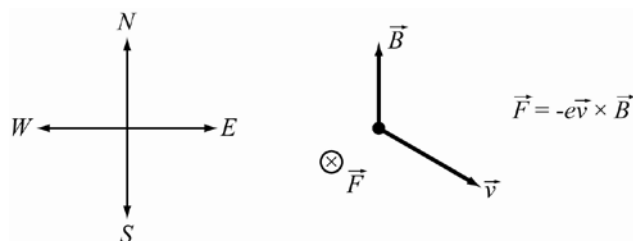

The magnetic force acts in a direction perpendicular to both the velocity and magnetic fields. Since these are both in the horizontal plane, the force acts into or out of the page. The right-hand rule shows that a positive charge experiences a net force outwards. Thus, for the negatively charged electron, the force is directed inwards.

27.22. Recall that a velocity selector works with perpendicular magnetic and electric fields. At the Earth's surface, there is an approximately perpendicular relation between the electric and magnetic fields. Thus, on a line perpendicular to E and B , charged particles will travel without deflection if they have the correct velocity. This velocity has a magnitude E/B . It is known that the Earth's magnetic field is approximately 0.3 gauss or $3 \cdot 10^{-5}$ T. Therefore, the value of E/B at the Earth's surface is of the order:

$$\frac{150 \text{ N}}{3 \cdot 10^{-5} \text{ T}} = 5 \cdot 10^6 \text{ m/s.}$$

When pointed west, magnetically speaking the beam would be un-deflected. Once you are facing West, North is on your right.

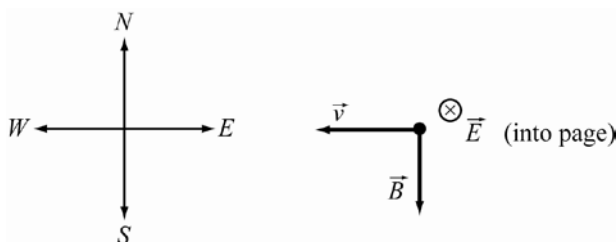

27.23. A cyclotron has both electric and magnetic fields. It is the alternating electric field which does the work to increase the particle's kinetic energy. Although the magnetic field does not do any work (it does not change the particle's kinetic energy), it nevertheless plays an important role in keeping the particle in a circular orbit. As the electric field accelerates the particle, the radius of the circular orbit increases so that the particle follows a spiral trajectory. The alternating electric field and the static uniform magnetic are crucial for the operation of the cyclotron as a particle accelerator.

Exercises

27.24.

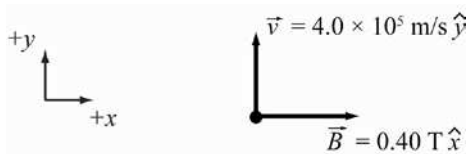

$\vec{F}_B = q\vec{v} \times \vec{B}$, $F_B = |q|vB \sin \theta$, $\theta = 90^\circ$ and $q = e$, so, $F_B = evB$. Inserting the values gives:

$$F_B = (1.602 \cdot 10^{-19} \text{ C})(4.00 \cdot 10^5 \text{ m/s})(0.400 \text{ T}) = 2.563 \cdot 10^{-14} \text{ N} \approx 2.56 \cdot 10^{-14} \text{ N.}$$

27.25. $\vec{F}_B = q\vec{v} \times \vec{B}$, $F_B = |q|vB\sin\theta$, $\theta = 90^\circ$, $q = -2e \Rightarrow |\vec{F}_B| = F_B = +2evB \Rightarrow$

$$B = \frac{F_B}{2ev} = \frac{3.00 \cdot 10^{-18} \text{ N}}{2(1.602 \cdot 10^{-19} \text{ C})1.00 \cdot 10^5 \text{ m/s}} = 9.363 \cdot 10^{-5} \text{ T} \approx 9.36 \cdot 10^{-5} \text{ T}.$$

- 27.26. **THINK:** The particle moves in a straight line at constant speed. Thus, the net force must be zero. The electric force is the negative of the magnetic force. Using the right-hand rule, the direction of the magnetic field can be determined. For the magnitude, set the magnitude of the net force to zero. $q = 10.0 \mu\text{C}$, $v = 300. \text{ m/s}$ and $E = 100. \text{ V/m}$.

SKETCH:

(a)

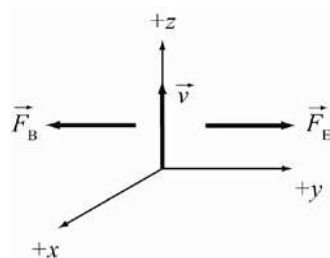

(b)

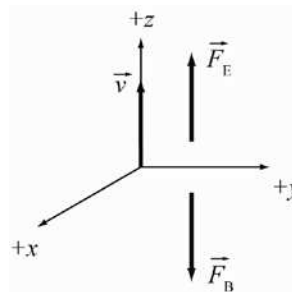

RESEARCH: $\vec{F} = q\vec{E} + q(\vec{v} \times \vec{B}) = 0$

SIMPLIFY: $q(\vec{E} + \vec{v} \times \vec{B}) = 0 \Rightarrow \vec{v} \times \vec{B} = -\vec{E}$

(a) $\vec{v} \times \vec{B} = -E\hat{y} \Rightarrow (v\hat{z} \times \vec{B}) = -E\hat{y} \Rightarrow \vec{B} = -\frac{E}{v}\hat{x}$ (by the right-hand rule)

(b) $\vec{v} \times \vec{B} = -E\hat{z} \Rightarrow (v\hat{z} \times \vec{B}) = -E\hat{z}$

There is no solution. $\hat{z} \times \vec{B}$ is either zero, or a vector in the xy -plane.

CALCULATE:

(a) $|\vec{B}| = -\frac{100. \text{ V/m}}{300. \text{ m/s}} = -\frac{1}{3} \text{ T} = -0.3333 \text{ T}$; so $\vec{B} = -0.333\hat{x} \text{ T}$.

(b) No solution. No magnetic field will keep the particle moving at a constant speed in a straight line.

ROUND:

(a) $\vec{B} = -0.333\hat{x} \text{ T}$

(b) Not applicable.

DOUBLE-CHECK: No Lorentz force can counteract an electric force in z -direction, if the particle is also traveling in z -direction, because the Lorentz force is always perpendicular to the velocity vector.

- 27.27. **THINK:** First determine the components of the force. Once the components are determined, the magnitude and the direction of the force can be found. $q = 20.0 \mu\text{C}$, $v = 50.0 \text{ m/s}$, $B_z = 0.700 \text{ T}$ and $B_y = 0.300 \text{ T}$.

SKETCH:

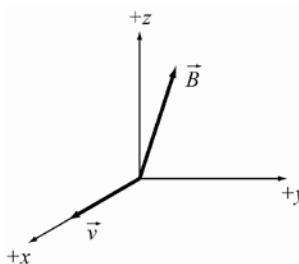

RESEARCH: $\vec{F} = q\vec{v} \times \vec{B}$, $\hat{x} \times \hat{y} = \hat{z}$, $\hat{y} \times \hat{z} = \hat{x}$, $\hat{z} \times \hat{x} = \hat{y}$, $\vec{A} \times \vec{B} = -\vec{B} \times \vec{A}$

SIMPLIFY: $\vec{F} = qv\hat{x} \times (B_z\hat{z} + B_y\hat{y}) = qv(B_z\hat{x} \times \hat{z} + B_y\hat{x} \times \hat{y}) = qv(-B_z\hat{y} + B_y\hat{z}) = F_y\hat{y} + F_z\hat{z}$

$$|\vec{F}| = \sqrt{F_y^2 + F_z^2} = qv\sqrt{B_z^2 + B_y^2}$$

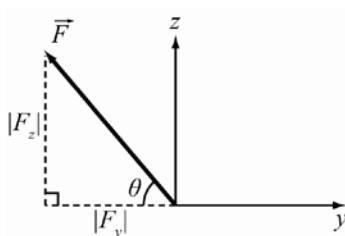

$$\theta = \tan^{-1}\left(\frac{|F_z|}{|F_y|}\right) = \tan^{-1}\left(\frac{|B_y|}{|B_z|}\right) = \tan^{-1}\left(\frac{B_y}{B_z}\right)$$

CALCULATE: $|\vec{F}| = (20.0 \cdot 10^{-6} \text{ C})(50.0 \text{ m/s})\sqrt{(0.700 \text{ T})^2 + (0.300 \text{ T})^2} = 7.616 \cdot 10^{-4} \text{ N}$

$$\theta = \tan^{-1}\left(\frac{0.300 \text{ T}}{0.700 \text{ T}}\right) = 23.2^\circ$$

ROUND: $|\vec{F}| = 7.62 \cdot 10^{-4} \text{ N}$ and the direction of the force is in the yz -plane, $\theta = 23.2^\circ$ above the negative y -axis.

DOUBLE-CHECK: These results are reasonable. The Right Hand Rule dictates that the direction of the magnetic force be in the $-y, +z$ -plane.

- 27.28. **THINK:** The only force acting on the particle is the magnetic force. The components of this force can be determined, and then the points where all the components vanish can be determined

SKETCH:

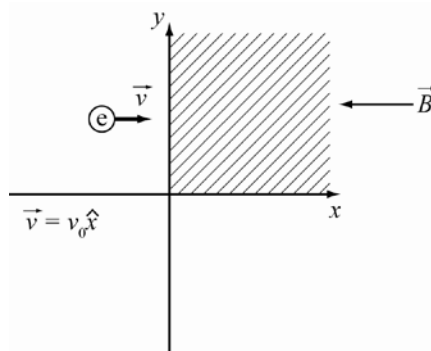

RESEARCH: $\vec{F} = q\vec{v} \times \vec{B} = 0$, $\hat{x} \times \hat{y} = \hat{z}$, $\hat{y} \times \hat{z} = \hat{x}$, $\hat{z} \times \hat{x} = \hat{y}$, $\vec{A} \times \vec{B} = -\vec{B} \times \vec{A}$

SIMPLIFY:

$$\begin{aligned} \vec{F} = 0 &= qv_0\hat{x} \times [(x-az)\hat{y} \times (xy-b)\hat{z}] = qv_0[(x-az)(\hat{x} \times \hat{y}) + (xy-b)(\hat{x} \times \hat{z})] \\ &= qv_0[(x-az)\hat{z} + (b-xy)\hat{y}] = 0 \end{aligned}$$

$$\Rightarrow x - az = 0 \Rightarrow x = az.$$

$$\Rightarrow b - xy = 0 \Rightarrow xy = b.$$

The magnetic field will exert no force on the electron at all points satisfying the two equations, $x = az$ and $xy = b$. The locus of these points in three dimensions is represented by the thick black line in the following figure.

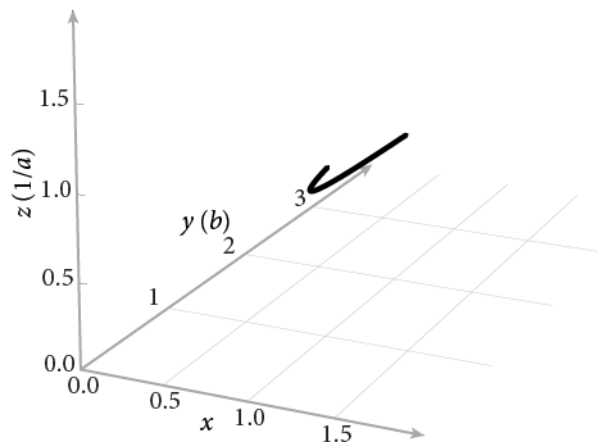

CALCULATE: Not necessary.

ROUND: Not necessary.

DOUBLE-CHECK: For the given field, the results are correct. We can check to see if the magnetic field in this problem is physical. The fundamental equations, which govern the behavior of all electric and magnetic fields are called Maxwell's equations, named after James Clerk Maxwell, who first unified them. One of these equations states that:

$$\vec{\nabla} \cdot \vec{B} = \frac{\partial B_x}{\partial x} \hat{x} + \frac{\partial B_y}{\partial y} \hat{y} + \frac{\partial B_z}{\partial z} \hat{z} = 0.$$

This equation is satisfied by the given \vec{B} field so the specified field can exist. Interestingly, $\vec{\nabla} \cdot \vec{B} = 0$ exists because as far as is now known, magnetic monopoles do not exist, only magnetic dipoles. This is in contrast to electric fields where monopoles (isolated positive and negative charges) do exist.

27.29. $\Delta K = \Delta U$

$$K = eV \Rightarrow \frac{1}{2}mv^2 = eV \Rightarrow v = \sqrt{\frac{2eV}{m}}$$

$$B = \frac{mv}{er} = \frac{m}{er} \sqrt{\frac{2eV}{m}} = \frac{1}{r} \sqrt{\frac{2mV}{e}} = \frac{1}{0.200 \text{ m}} \sqrt{\frac{2(1.67 \cdot 10^{-27} \text{ kg})(400. \text{ V})}{1.602 \cdot 10^{-19} \text{ C}}} = 1.44 \cdot 10^{-2} \text{ T.}$$

27.30.

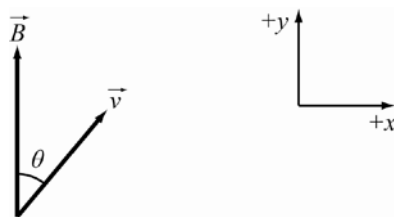

$\theta = 35.0^\circ$, $|\vec{B}| = 0.0400 \text{ T} = B$, $|\vec{v}| = 4.00 \cdot 10^5 \text{ m/s} = v$, $v_x = v \sin \theta = v_\perp$ (perpendicular to \vec{B}),
 $v_y = v \cos \theta = v_\parallel$ (parallel to \vec{B}).

$$(a) \quad r = \frac{mv_\perp}{|q|B} = \frac{(9.11 \cdot 10^{-31} \text{ kg})(4.00 \cdot 10^5 \text{ m/s})(\sin 35.0^\circ)}{(1.602 \cdot 10^{-19} \text{ C})(0.0400 \text{ T})} = 3.262 \cdot 10^{-5} \text{ m}$$

(b) The time it takes to travel 2π radians around the circle is:

$$t = \frac{2\pi r}{v_\perp} = \frac{2\pi}{v_\perp} \left(\frac{mv_\perp}{|q|B} \right) = \frac{2\pi m}{|q|B}.$$

During this time it is moving forward with speed v_{\parallel} , and will move a distance, d , given by:

$$d = v_{\parallel} t = \frac{v_{\parallel} 2\pi m}{|q|B} = \frac{2\pi m v \cos\theta}{|q|B} = \frac{2\pi(9.11 \cdot 10^{-31} \text{ kg})(4.00 \cdot 10^5 \text{ m/s}) \cos 35.0^\circ}{(1.602 \cdot 10^{-19} \text{ C})(0.0400 \text{ T})} = 2.926 \cdot 10^{-4} \text{ m}.$$

ROUND:

a) $r = 3.26 \cdot 10^{-5} \text{ m}.$

b) $d = 2.93 \cdot 10^{-4} \text{ m}.$

- 27.31.** By Newton's second law, the quantity $d\vec{p}/dt$ is equal to the net force on the particle, exerted by the electric and magnetic fields. By the Work Energy Theorem, the quantity dK/dt is the rate at which work is done on the particle by the electric field. The magnetic force is always perpendicular to the particle's velocity and does no work. Hence, these quantities can be written:

$$\frac{d\vec{p}}{dt} = -q(\vec{E} + \vec{v} \times \vec{B}), \quad \frac{dK}{dt} = -q\vec{E} \cdot \vec{v}.$$

Slightly modified, these relationships can be put into a form that transforms simply from one reference frame to another according to Einstein's Special Theory of Relativity (see Chapter 35). They can be used to show that in a world governed by Einsteinian dynamics, the simplest force law that can be written is the combined electromagnetic force law above.

27.32. $r = \frac{mv}{|q|B} = \frac{1.88 \cdot 10^{-28} \text{ kg}(3.00 \cdot 10^6 \text{ m/s})}{1.602 \cdot 10^{-19} \text{ C}(0.500 \text{ T})} = 7.04 \cdot 10^{-3} \text{ m} = 7.04 \text{ mm}$

27.33.

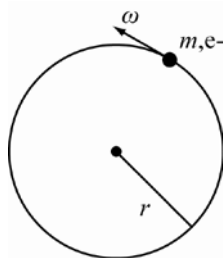

The net force is directed toward the center of the circle. From the right-hand rule, a positive charge requires the magnetic field to be oriented into the plane, in the negative z -direction. Since an electron is negatively charged, it can be concluded that the field points out of the page, along the positive z -direction. The magnitude is given by:

$$\omega = \frac{|q|B}{m} \Rightarrow B = \frac{m\omega}{|q|} = \frac{(9.11 \cdot 10^{-31} \text{ kg})(1.20 \cdot 10^{12} \text{ s}^{-1})}{1.602 \cdot 10^{-19} \text{ C}} = 6.824 \text{ T} \Rightarrow \vec{B} = 6.82\hat{z} \text{ T}.$$

27.34. $r = \frac{mv}{|q|B}, \quad K = \frac{1}{2}mv^2 \Rightarrow v = \sqrt{\frac{2K}{m}} \Rightarrow r = \frac{m}{|q|B} \left(\sqrt{\frac{2K}{m}} \right) = \frac{\sqrt{2Km}}{|q|B}$

The mass, charge and fields are the same for the two particles.

$$\frac{r_1}{r_2} = \frac{\sqrt{2K_1 m}}{|q|B} \left(\frac{|q|B}{\sqrt{2K_2 m}} \right) = \sqrt{\frac{K_1}{K_2}} = \sqrt{\frac{4.00 \cdot 10^2 \text{ eV}}{2.00 \cdot 10^2 \text{ eV}}} = 1.41$$

So, the 400 eV particle travels in an orbit of radius 1.41 times that of the radius of the 200 eV particle.

- 27.35. THINK:** The proton moves through a magnetic field. The component of the velocity parallel to the field is unchanged. The component perpendicular, however, will create a circular motion. The velocity of the proton is $\vec{v} = (1.00\hat{x} + 2.00\hat{y} + 3.00\hat{z})10^5 \text{ m/s}$ and the field is $B = 0.500\hat{z} \text{ T}.$

SKETCH:

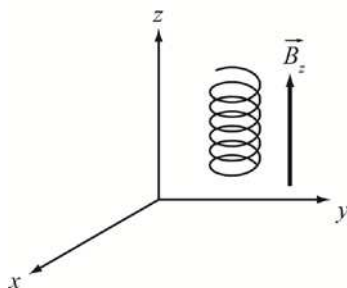

RESEARCH: The radius of the circular motion in a magnetic field is:

$$r = \frac{mv}{|q|B}$$

SIMPLIFY: The speed in the xy -plane is $v_{xy} = \sqrt{v_x^2 + v_y^2}$. The radius of the circle is: $r = \frac{m}{|q|B} \sqrt{v_x^2 + v_y^2}$.

CALCULATE: $r = \frac{1.6726 \cdot 10^{-27} \text{ kg}}{(1.6022 \cdot 10^{-19} \text{ C})(0.50 \text{ T})} \sqrt{(1.00 \cdot 10^5 \text{ m/s})^2 + (2.00 \cdot 10^5 \text{ m/s})^2} = 4.6688 \cdot 10^{-3} \text{ m}$

$$v_{xy} = \sqrt{(1.00 \cdot 10^5 \text{ m/s})^2 + (2.00 \cdot 10^5 \text{ m/s})^2} = 2.23607 \cdot 10^5 \text{ m/s}$$

ROUND: The values are given to two significant figures. The proton will follow a helical path with a velocity of $3.00 \cdot 10^5 \text{ m/s}$ along the z -axis, with the circular motion in the xy -plane having a speed of $2.24 \cdot 10^5 \text{ m/s}$ and a radius of 4.67 mm.

DOUBLE-CHECK: The angular velocity is on the same order of magnitude as the original velocity. Dimensional analysis confirms the units are correct.

- 27.36. **THINK:** The copper sphere accelerates in the region of the electric field, and gains an amount of kinetic energy equal to the potential difference times the charge on the sphere. At this speed, the sphere enters the magnetic field, which curves its path. The sphere has a mass of $m = 3.00 \cdot 10^{-6} \text{ kg}$ and a charge of $5.00 \cdot 10^{-4} \text{ C}$. The potential difference is $V = 7000 \text{ V}$, and the magnetic field is $B = 4.00 \text{ T}$, perpendicular to the direction of the particle's initial velocity.

SKETCH:

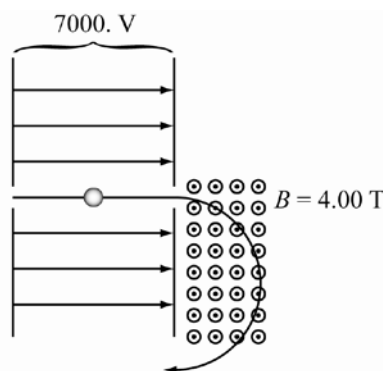

RESEARCH: The kinetic energy will be $KE = mv^2 / 2 = PE = qV$. The radius of the path in the magnetic field is $r = mv / qB$.

SIMPLIFY: The velocity is $v^2 = 2qV / m$ or $v = \sqrt{2qV / m}$. The radius is then:

$$r = \frac{mv}{qB} = \frac{m}{qB} \sqrt{\frac{2qV}{m}} = \frac{1}{B} \sqrt{\frac{2mV}{q}}$$

CALCULATE: $r = \frac{1}{4.00 \text{ T}} \sqrt{\frac{2(3.00 \cdot 10^{-6} \text{ kg})(7000. \text{ V})}{5.00 \cdot 10^{-4} \text{ C}}} = 2.29129 \text{ m}$

ROUND: The least precise values have three significant figures, so the radius of the copper's path in the magnetic field is 2.29 m.

DOUBLE-CHECK: The very large potential difference accelerates the sphere to a high speed, therefore a large radius of curvature is reasonable.

- 27.37. **THINK:** The particles will move in circular, clockwise paths (in the direction of $\vec{v} \times \vec{B}$) within the magnetic field. The radius of curvature of the path is proportional to the mass of the particle, and inversely proportional to the charge of the particle. Both particles move at the same speed within the same magnetic field. The radii, charges and masses of the particles can then be compared.

SKETCH:

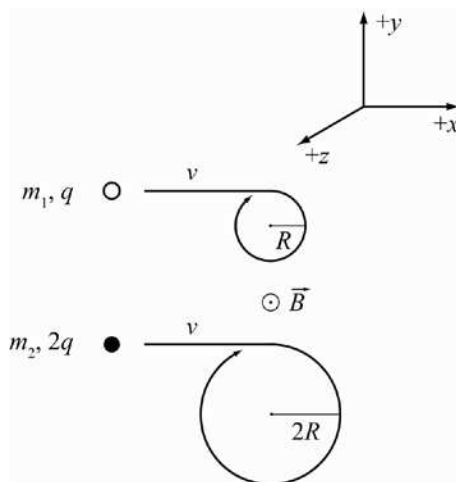

RESEARCH: The radius is related to the mass and charge of the particles by $r = mv / |q|B$. At the instant that the particles enter the magnetic field, the magnetic force acting on them is $\vec{F}_B = q\vec{v} \times \vec{B}$. For the particles to travel in a straight line, the force on the particles due to the electric field must oppose the force due to the magnetic field: $\vec{F}_E = -\vec{F}_B \Rightarrow q\vec{E} = -q\vec{v} \times \vec{B}$.

SIMPLIFY: Since the velocity and the magnetic field is the same for both particles, $\frac{v}{B} = \frac{r_1 q_1}{m_1} = \frac{r_2 q_2}{m_2}$. The ratio of the masses is:

$$\frac{m_1}{m_2} = \frac{r_1 q_1}{r_2 q_2} = \frac{Rq}{2R(2q)} = \frac{1}{4}.$$

For the particles to travel in a straight line,

$$q\vec{E} = -q\vec{v} \times \vec{B} = -qvB(\hat{x} \times \hat{z}) = -qvB(-\hat{y})$$

$$\vec{E} = vB\hat{y}.$$

Therefore, the electric field must have magnitude $E = vB$ and point in the positive y -direction in order for the particles to move in a straight line.

CALCULATE: Not applicable.

ROUND: Not applicable.

DOUBLE CHECK: Since the mass increases with radius and charge, it makes sense that the particle with the smaller charge and radius has the smaller mass.

- 27.38. **THINK:** The question goes through the elements of a mass spectrometer. A source of gold and molybdenum emits singly ionized atoms at various velocities toward the velocity filter. The velocity filter described in the diagram uses a magnetic field, \vec{B}_1 , and an electric field \vec{E} to select the velocity of the

exiting particles. It can be shown that the velocity of the ions must be $v = B_1 / E$. If the velocities are smaller, the force due to the electric field will dominate pushing the particles off the path through the filter. If the velocity is greater than B_1 / E then the force due to the magnetic field dominates and will also push the ion off its path. The particles exit the filter with the selected velocity and enter the mass spectrometer. The magnetic field inside the mass spectrometer curves the path of the entering particles based on their mass and charge. Thus, particles of different charges and masses can be separated. The gold and molybdenum have beams in the mass spectrometer with diameters of $d_2 = 40.00$ cm and $d_1 = 19.81$ cm, respectively. The mass of the gold ion is $m_{\text{gold}} = 3.271 \cdot 10^{-25}$ kg. Both ion types have charges of $q = e = 1.602 \cdot 10^{-19}$ C. The electric and magnetic field within the velocity filter are $\vec{E} = 1.789 \cdot 10^4 \hat{y}$ V/m and $\vec{B}_1 = 1.000 \hat{z}$ T, respectively.

SKETCH:

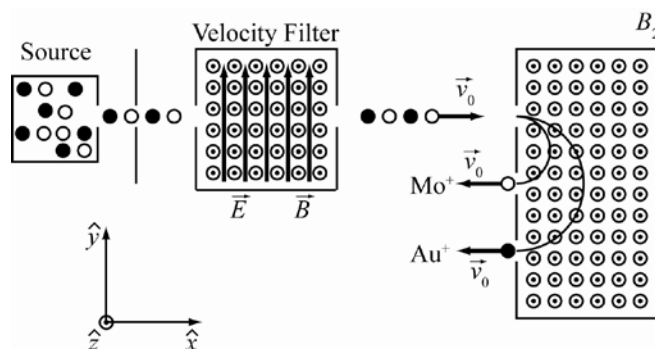

RESEARCH:

(a)

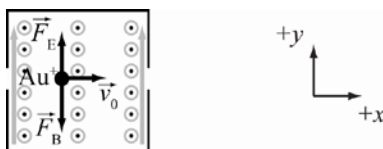

(b) For the ions to pass through the velocity filter, the force due to the electric field must cancel the force due to the magnetic field: $F_e = qE = qv_0B$. The forces due to an electric and magnetic field are given by $\vec{F}_e = q\vec{E}$ and $\vec{F}_B = q\vec{v}_0 \times \vec{B}$, respectively.

(c) The radius of the ion's path in a magnetic field is given by $R = mv / (|q|B)$.

(d) The mass of the molybdenum can be determined by setting the velocity, charge and magnetic field equal to each other for each ion and comparing.

SIMPLIFY:

(b) The velocity of the exiting particle is then $v_0 = E / B_1$. This velocity does not depend on any parameters of the ions.

(c) The radius of the circular path is $r = mv_0 / (|q|B_2)$.

(d) $\frac{v_0}{|q|B_2} = \frac{r_{\text{Au}^+}}{m_{\text{Au}^+}} = \frac{r_{\text{Mo}^+}}{m_{\text{Mo}^+}}$. Solving for the mass of the molybdenum gives: $m_{\text{Mo}^+} = \frac{r_{\text{Mo}^+}}{r_{\text{Au}^+}} m_{\text{Au}^+}$.

CALCULATE:

(b) $v_0 = \frac{1.789 \cdot 10^4 \text{ V/m}}{1.000 \text{ T}} = 1.789 \cdot 10^4 \text{ m/s}$

(d) $m_{\text{Mo}^+} = \frac{19.81 \text{ cm}/2}{40.00 \text{ cm}/2} (3.271 \cdot 10^{-25} \text{ kg}) = 1.6199 \cdot 10^{-25} \text{ kg}$

ROUND: The values are reported to four significant figures.

(b) The velocity filter allows particles traveling $1.789 \cdot 10^4$ m/s to exit the filter. This value does not depend on the type of ion. It is based on the fact that the particle is charged and only depends on the fields.

(c) The equation for the radius of the semi-circular path is $r = mv / |q|B$.

(d) The mass of the molybdenum ion is $1.620 \cdot 10^{-25}$ kg.

DOUBLE-CHECK: The calculated velocity has appropriate units, and the actual mass of molybdenum is about $1.64 \cdot 10^{-25}$ kg. These facts help to support the answers as reasonable.

- 27.39. THINK:** This question explores the function of an accelerator. The ${}^3\text{He}^+$ ion source ejects particles into region 1. The magnetic field in this region bends the path of the ${}^3\text{He}^+$ particle into a semicircular path. Particles then enter the 3rd region containing an electric field that accelerates the particles toward region 2. In region 2, the path of the particles is bent into a semicircle again. This time the particles do not pass through an electric field. The particle then enters region 1 again. The path is bent again and the particle accelerates once more before it exits the accelerator. The ${}^3\text{He}^+$ ions have a mass of $m = 5.02 \cdot 10^{-27}$ kg and a charge of $q = e = 1.60 \cdot 10^{-19}$ C. The ions start with a kinetic energy of:

$$K = 4.00 \text{ keV} = \frac{4.00 \cdot 10^3 \text{ eV} (1.60 \cdot 10^{-19} \text{ J})}{1.00 \text{ eV}} = 6.40 \cdot 10^{-16} \text{ J}.$$

The magnetic field in region 1 is $B_1 = 1.00$ T. In region 2, the magnetic field, B_2 , is unknown. The 3rd region contains an electric field of $E = 60.0$ kV/m and has a length of $l = 50.0$ cm = 0.500 m. The distance between the source and the aperture is $d = 7.00$ cm = 0.0700 m.

SKETCH:

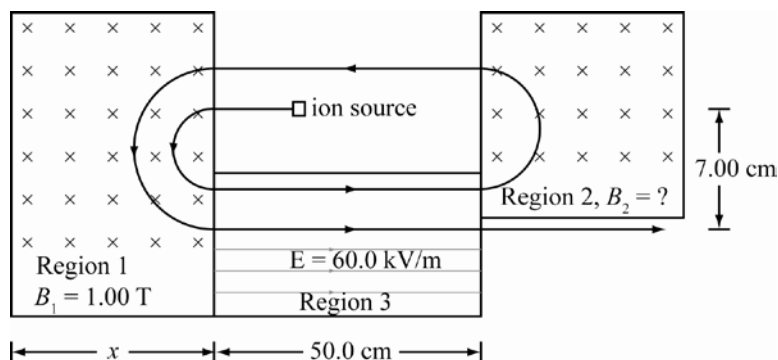

RESEARCH: The kinetic energy is equal to $KE = mv^2 / 2$. The radius of the path of a charged particle in a magnetic field is $r = mv / |q|B$. The force on the particle in region 3 is $F_e = qE$, which must equal $F = ma$. With the acceleration of this region, the velocity at which it exits region 3 can be determined from:

$$v_f^2 = v_0^2 + 2ad.$$

SIMPLIFY: Let v_0 , v_1 and v_2 be the velocity of the ion after it is ejected from the source, region 3 and region 3 the second time, respectively. The velocity after the source is given by $v_0 = \sqrt{2KE / m}$. The acceleration of region 3 is $ma = qE$ or $a = qE / m$. The velocity, v_1 , is then $v_1 = \sqrt{v_0^2 + 2al} = \sqrt{v_0^2 + 2qEl / m}$. Similarly, the velocity, v_2 , is given by:

$$v_2 = \sqrt{v_1^2 + 2al} = \sqrt{v_1^2 + 2qEl / m} = \sqrt{v_0^2 + 2qEl / m + 2qEl / m} = \sqrt{v_0^2 + 4qEl / m}.$$

The radius of the path, the first time the ion enters region 1 is $R_1 = mv_0 / qB_1$. The radius of the path in region 2 is $R_2 = mv_1 / qB_2$. The radius of the path the second time it goes through region 1 is $R_3 = mv_1 / qB_1$. For the particle to exit the aperture, a distance $d = 7$ cm from the ion source:

$$2R_1 - 2R_2 + 2R_3 = 2 \left(\frac{mv_0}{qB_1} - \frac{mv_1}{qB_2} + \frac{mv_1}{qB_1} \right) = 2 \frac{m}{q} \left(\frac{v_0 + v_1}{B_1} - \frac{v_1}{B_2} \right) = d.$$

Solve for B_2 to determine the magnetic field required in region 2:

$$\begin{aligned} \frac{v_0 + v_1}{B_1} - \frac{v_1}{B_2} &= \frac{qd}{2m} \Rightarrow B_2 \left(\frac{v_0 + v_1}{B_1} \right) - v_1 = \left(\frac{qd}{2m} \right) B_2 \\ \Rightarrow B_2 \left[\frac{v_0 + v_1}{B_1} - \frac{qd}{2m} \right] &= v_1 \Rightarrow B_2 = \frac{v_1}{(v_0 + v_1)/B_1 - (qd/2m)} = \frac{2mB_1v_1}{2m(v_0 + v_1) - qdB_1}. \end{aligned}$$

Region 1 must have dimensions larger than $R_3 = mv_1/qB_1$. The velocity of the ions as they exit the accelerator is $v_2 = \sqrt{v_0^2 + (4qEl/m)}$.

CALCULATE: $v_0 = \sqrt{\frac{2(6.40 \cdot 10^{-16} \text{ J})}{5.02 \cdot 10^{-27} \text{ kg}}} = 504995 \text{ m/s}$

$$v_1 = \sqrt{\frac{2(6.40 \cdot 10^{-16} \text{ J})}{5.02 \cdot 10^{-27} \text{ kg}} + \frac{2(1.60 \cdot 10^{-19} \text{ C})(60.0 \cdot 10^3 \text{ V/m})(0.500 \text{ m})}{5.02 \cdot 10^{-27} \text{ kg}}} = 1472186 \text{ m/s}$$

$$v_2 = \sqrt{\frac{2(6.40 \cdot 10^{-16} \text{ J})}{5.02 \cdot 10^{-27} \text{ kg}} + \frac{4(1.60 \cdot 10^{-19} \text{ C})(60.0 \cdot 10^3 \text{ V/m})(0.500 \text{ m})}{5.02 \cdot 10^{-27} \text{ kg}}} = 2019822 \text{ m/s}$$

$$B_2 = \frac{2(5.02 \cdot 10^{-27} \text{ kg})(1.00 \text{ T})(1472186 \text{ m/s})}{2(5.02 \cdot 10^{-27} \text{ kg})(504955 \text{ m/s} + 1472186 \text{ m/s}) - (1.60 \cdot 10^{-19} \text{ C})(0.0700 \text{ m})(1.00 \text{ T})} = 1.70866 \text{ T}$$

$$x = R_3 = \frac{mv_1}{qB_1} = \frac{(5.02 \cdot 10^{-27} \text{ kg})(1472186 \text{ m/s})}{(1.60 \cdot 10^{-19} \text{ C})(1.00 \text{ T})} = 0.046190 \text{ m}$$

ROUND: The values are reported to three significant figures.

(a) The magnetic field of region 2 is 1.71 T.

(b) The region must have dimensions greater than 4.62 cm.

(c) The velocity the ions leave the accelerator is $2.02 \cdot 10^6 \text{ m/s}$.

DOUBLE-CHECK: Dimensional analysis confirms all the answers are in the correct units. These results are reasonable.

- 27.40. The force on a wire of length l and current i in a magnetic field B is given by $\vec{F} = li \times \vec{B} = liB \sin \theta$. The magnitude of the magnetic field is:

$$B = \frac{F}{li \sin \theta} = \frac{0.500 \text{ N}}{(2.00 \text{ m})(24.0 \text{ A}) \sin 30.0^\circ} = 0.02083 \text{ T} \approx 20.8 \text{ mT}.$$

- 27.41. The force on the wire is $\vec{F}_{\text{net}} = m\vec{a} = \vec{F}_B + \vec{F}_g = i\vec{L} \times \vec{B} + mg\hat{y} = iLB(-\hat{x} \times -\hat{z}) + mg\hat{y} = -iLB\hat{y} + mg\hat{y}$. For the conductor to stay at rest, $a = 0$ or $mg = iLB$. The suspended mass is then:

$$m = \frac{iLB}{g} = \frac{(20.0 \text{ A})(0.200 \text{ m})(1.00 \text{ T})}{(9.81 \text{ m/s}^2)} = 0.408 \text{ kg}.$$

- 27.42.

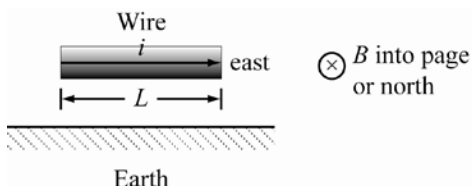

For the wire to levitate, the force of the magnetic field must equal the force of gravity on the wire:

$$iLB = mg = \rho Vg = \rho\pi r^2 Lg.$$

The current required to levitate the wire is:

$$i = \frac{\rho\pi r^2 g}{B} = \frac{(8940 \text{ kg/m}^3)\pi(0.000500 \text{ m})^2(9.81 \text{ m/s}^2)}{(0.500 \text{ G})(0.0001 \text{ T/G})} = 1.38 \cdot 10^3 \text{ A}.$$

- 27.43. THINK:** First, the relationship between the current in the sheet and the magnetic field must be established. The force on the sheet can then be determined. The sheet has length, $L = 1.00 \text{ m}$, width, $w = 0.500 \text{ m}$, and thickness, $t = 1.00 \text{ mm} = 0.00100 \text{ m}$. The magnetic field, $B = 5.00 \text{ T}$, is perpendicular to the sheet and the current flowing through it. The current is $i = 3.00 \text{ A}$.

SKETCH:

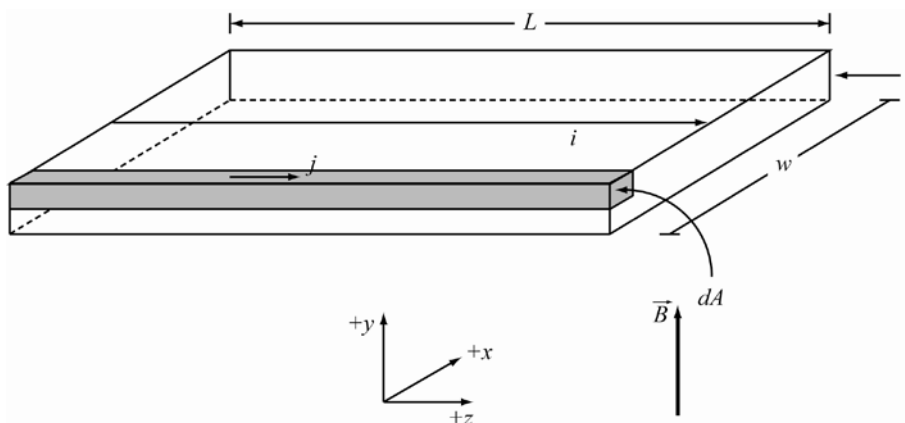

RESEARCH: The force on a wire carrying current in a magnetic field is $\vec{F} = i\vec{L} \times \vec{B}$.

SIMPLIFY: Imagine that the sheet is constructed of many wires of length, L , carrying a charge dq . The infinitesimal force on the sheet due to the wire is $d\vec{F} = dq\vec{L} \times \vec{B}$. Since L is perpendicular to B , $dF = dqLB$. The infinitesimal current is equal to the current density times the differential area, $dq = j dA$. The current density is equal to the total current divided by the cross sectional area, $j = i/A = i/wt$. The infinitesimal force is then $dF = dqLB = j dA LB = iLB dA / wt$. Integrating over the area gives:

$$F = \frac{i}{wt} LB \int_0^w dx \int_0^t dy = \frac{i}{wt} LBwt = iLB.$$

This is the same result as that for a wire.

CALCULATE: $F = (3.00 \text{ A})(1.00 \text{ m})(5.00 \text{ T}) = 15.0 \text{ N}$

ROUND: The result is reported to two significant figures. The force on the sheet is 15.0 N . This is the same as the force on a wire of the same length with the same current and magnetic field.

DOUBLE-CHECK: The force on the sheet is the same as the force on a wire. This is expected since only the magnitude of the current matters in a wire (the size of the wire is not relevant).

- 27.44. **THINK:** For the rod to remain stationary, the forces of the magnetic field and gravity along the plane of the incline must cancel.

SKETCH:

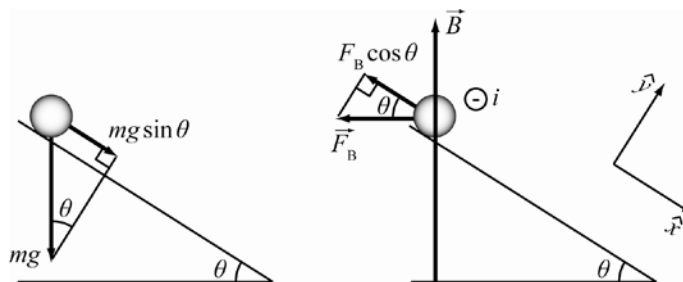

RESEARCH: The force due to the magnetic field is $|\vec{F}_B| = i\vec{L} \times \vec{B} = iLB$. Along the plane of the incline, the force is $F_{Bx} = F_B \cos \theta = iLB \cos \theta$. The force due to gravity along the surface of the incline is $F_{gx} = mg \sin \theta$.

SIMPLIFY: Equating these forces gives the current:

$$iLB \cos \theta = mg \sin \theta \quad \text{or} \quad i = \frac{mg}{LB} \tan \theta.$$

The current must go out of the page in the side view of the system, by the right-hand rule.

CALCULATE: Not applicable.

ROUND: Not applicable.

DOUBLE CHECK: According to the derived expression, the strength of the current required to hold the wire stationary decreases as the magnetic field increases, which is logical.

- 27.45. **THINK:** The loop will experience a torque in the presence of a magnetic field as discussed in the chapter. The torque is also equal to the moment of inertia of the loop times its angular acceleration. The loop is square with sides of length, $d = 8.00$ cm and current, $i = 0.150$ A. The wire has a diameter of 0.500 mm (which corresponds to a radius of $r = 0.250$ mm) and a density of $\rho = 8960$ kg/m³. The magnetic field is $B = 1.00$ T and points 35.0° away from the normal of the loop.

SKETCH:

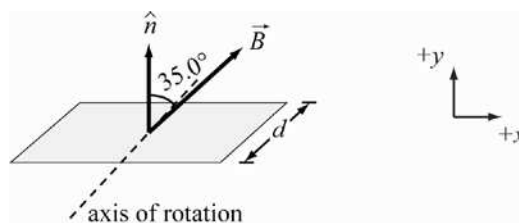

RESEARCH: The torque on the loop is $\tau = iAB \sin \theta$. The moment of inertia for a rod about its center is $I = Md^2 / 12$. The moment of a rod about an axis along its length is $I = \rho \pi r^4 L / 4$. The parallel axis theorem states $I_{\text{off center}} = I_{\text{cm}} + Md^2$.

SIMPLIFY: The moment of inertia of the loop is:

$$\begin{aligned} I &= \frac{1}{12}Md^2 + \frac{1}{12}Md^2 + \left[\frac{1}{4}\rho\pi r^4 d + M\left(\frac{d}{2}\right)^2 \right] + \left[\frac{1}{4}\rho\pi r^4 d + M\left(\frac{d}{2}\right)^2 \right] \\ &= \frac{1}{6}Md^2 + \frac{1}{2}\rho\pi r^4 d + \frac{1}{2}Md^2 = \left(\frac{1}{6} + \frac{1}{2}\right)Md^2 + \frac{1}{2}\rho\pi r^4 d = \frac{4}{6}(\rho\pi r^2 d)d^2 + \frac{1}{2}\rho\pi r^4 d = \frac{2}{3}\rho\pi r^2 d^3 + \frac{1}{2}\rho\pi r^4 d. \end{aligned}$$

The angular acceleration is $\tau = I\alpha = iAB \sin \theta$ or $\alpha = iAB \sin \theta / I$.

$$\Rightarrow \alpha = \frac{id^2 B \sin \theta}{\rho\pi r^2 d^2 (2d/3 + r^2/2d)} = \frac{iB \sin \theta}{\rho\pi r^2 (2d/3 + r^2/2d)}$$

CALCULATE:

$$\alpha = \frac{(0.150 \text{ A})(1.00 \text{ T})(\sin 35.0^\circ)}{(8960 \text{ kg/m}^3)\pi(0.000250 \text{ m})^2 \left\{ \left[2(0.0800 \text{ m})/3 \right] + \left[(0.000250 \text{ m})^2 / 2(0.0800 \text{ m}) \right] \right\}} = 916.94 \text{ rad/s}^2$$

ROUND: The values are given to two significant figures, thus the loop experiences an initial angular acceleration of $\alpha = 917 \text{ rad/s}^2$.

DOUBLE-CHECK: One Tesla represents a magnetic field of large magnitude, resulting in a correspondingly large acceleration. This result is reasonable.

- 27.46. **THINK:** The rail-gun uses a magnetic force to accelerate a current carrying wire. The wire has a radius of $r = 5.10 \cdot 10^{-4} \text{ m}$ and a density of $\rho = 8960 \text{ kg/m}^3$. The current through the wire is $1.00 \cdot 10^4 \text{ A}$ and the magnetic field is $B = 2.00 \text{ T}$. The wire travels a distance of $L = 1.00 \text{ m}$ before being ejected.

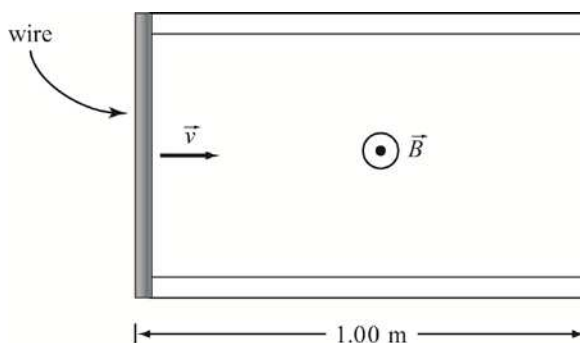
SKETCH:

RESEARCH: The force on the wire is $F = iLB$. The velocity of the wire is given by $v^2 = v_0^2 + 2ad$.

SIMPLIFY: The wire accelerates at a rate of:

$$a = \frac{F}{m} = \frac{iLB}{m} = \frac{iLB}{\rho\pi r^2 L} = \frac{iB}{\rho\pi r^2}.$$

The ejected velocity is:

$$v^2 = 2aL = \frac{2iBL}{\rho\pi r^2} \text{ or } v = \sqrt{\frac{2iBL}{\rho\pi r^2}}.$$

CALCULATE:
$$v = \sqrt{\frac{2(1.00 \cdot 10^4 \text{ A})(2.00 \text{ T})(1.00 \text{ m})}{(8960 \text{ kg/m}^3)\pi(5.10 \cdot 10^{-4} \text{ m})^2}} = 2337 \text{ m/s}$$

ROUND: The velocity is reported to two significant figures, like the given values. The wire exits the rail-gun at a speed of 2.34 km/s.

DOUBLE-CHECK: This result is very fast, about 7 times the speed of sound. This Navy has used this technology to accelerate 7 lb objects to this speed. As a comparison, this is double the speed of a bullet from a conventional rifle. A bullet weighs 55 g.

- 27.47. **THINK:** Using integration, the force on each segment of the loop can be found. From this, the net force can be found.

SKETCH:

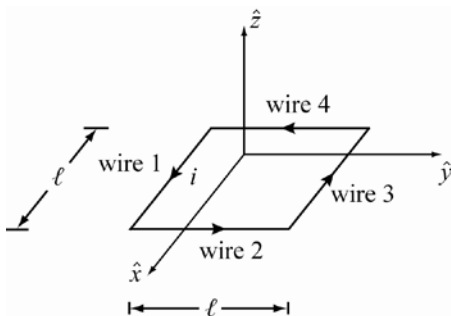

RESEARCH: In the differential limit, the magnetic force on current carrying wire in a magnetic field is:

$$d\vec{F}_B = i d\vec{L} \times \vec{B}.$$

SIMPLIFY: The force on wire 1 is:

$$\vec{F}_{B,1} = i \int_{-l/2}^{l/2} d\vec{x} \times \vec{B} = \frac{iB_0}{a} \int_{-l/2}^{l/2} d\hat{x} \times (z\hat{x} + x\hat{z}) = -\frac{iB_0}{a} \int_{-l/2}^{l/2} x dx \hat{y} = \frac{iB_0}{2a} [x^2]_{-l/2}^{l/2} = 0.$$

The force on wire 2 is:

$$\vec{F}_{B,2} = \frac{iB_0}{a} \int_{-l/2}^{l/2} d\hat{y} \times (z\hat{x} + x\hat{z}) = \frac{iB_0}{a} \int_{-l/2}^{l/2} (-z\hat{z} + x\hat{x}) dy = \frac{iB_0}{a} (-z\hat{z} + x\hat{x}) [y]_{-l/2}^{l/2} = \frac{iB_0 l}{a} (-z\hat{z} + x\hat{x}).$$

Along wire 2, $x = l/2$ and $z = 0$, so

$$\vec{F}_{B,2} = \frac{iB_0 l^2}{2a} \hat{x}.$$

Wire 3 is similar to wire 1, so $F_{B,3} = F_{B,1} = 0$. The force on wire 4 is:

$$\vec{F}_{B,4} = \frac{iB_0}{a} \int_{l/2}^{-l/2} -d\hat{y} \times (z\hat{x} + x\hat{z}) = \frac{iB_0}{a} (z\hat{z} - x\hat{x}) [y]_{l/2}^{-l/2} = \frac{iB_0 l}{a} (-z\hat{z} + x\hat{x}) = \frac{iB_0 l}{a} [-(0)\hat{z} + (l/2)\hat{x}] = \frac{iB_0 l^2}{2a} \hat{x}.$$

The net force is:

$$\vec{F}_{\text{net}} = \vec{F}_{B,2} + \vec{F}_{B,4} = \frac{iB_0 l^2}{a} \hat{x}.$$

CALCULATE: Not applicable.

ROUND: Not applicable.

DOUBLE CHECK: It is reasonable that the force is directly proportional to the magnetic field strength B_0 , the side length l of the loop, and the current i .

- 27.48. The loop experiences a torque of:

$$\tau = NiAB \sin \theta = 20.0(2.00 \cdot 10^{-3} \text{ A})(0.0800 \text{ m})(0.0600 \text{ m})50.0 \cdot 10^{-6} \text{ T} = 9.60 \cdot 10^{-9} \text{ N m}.$$

By the right-hand rule, the torque is in the positive y -direction. To hold the loop steady, a torque of the same magnitude must be applied in the negative y -direction.

- 27.49. The torque on the loop due to the magnetic field is $\tau = NiAB \sin \theta = NiAB$. This is equal to the applied torque, $\tau = rF$. Equating the torques gives the magnetic field:

$$B = \frac{rF}{NiA} = \frac{rF}{Ni\pi r^2} = \frac{F}{Ni\pi r} = \frac{1.2 \text{ N}}{120.(0.490 \text{ A})\pi(0.0480 \text{ m})} = 0.1353358 \text{ T} = 0.135 \text{ T}.$$

- 27.50. The torque on the pencil is:

$$\tau = NiAB \sin \theta = Ni\pi \left(\frac{d}{2}\right)^2 B \sin \theta = 20(3.00 \text{ A})\pi \left(\frac{0.00600 \text{ m}}{2}\right)^2 (5.00 \text{ T}) \sin 60.0^\circ = 7.35 \cdot 10^{-3} \text{ N m}.$$

- 27.51. **THINK:** The loop feels a torque if it carries a current in the presence of a uniform magnetic field. The maximum torque occurs when the magnetic moment of the loop is perpendicular to the magnetic field. The loop has a radius of $r_{\text{loop}} = 0.500$ m, density of $\rho = 8960$ kg/m³, and the wire has a cross-sectional area of $A = 1.00 \cdot 10^{-5}$ m². A potential difference of $\Delta V = 0.0120$ V is applied to the wire. The loop is in a magnetic field of $B = 0.250$ T.

SKETCH:

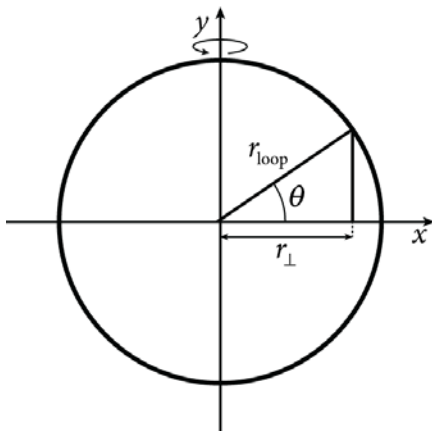

RESEARCH: The resistivity of the wire is given by $\rho_R = 16.78 \cdot 10^{-9}$ Ω m. The current is found using $\Delta V = iR$. The magnetic moment of the loop is given by $\vec{\mu} = iA\vec{n}$. The torque is equal to $\tau = I\alpha$, where I is the moment of inertia of the loop about its diameter. The moment of inertia is given by $I = \int r_{\perp}^2 dm$. The torque due to the magnetic field is given by $\vec{\tau} = \vec{\mu} \times \vec{B}$.

SIMPLIFY: The mass of the loop is given by

$$m = \int dm = \int_0^{2\pi} (\rho A r_{\text{loop}} d\theta) = 2\pi \rho A r_{\text{loop}}.$$

The moment of inertia of one half of the loop is:

$$I_{1/2} = \int r_{\perp}^2 dm = \int_{-\pi/2}^{\pi/2} (r_{\text{loop}} \cos\theta)^2 (\rho A r_{\text{loop}} d\theta) = \rho A r_{\text{loop}}^3 \int_{-\pi/2}^{\pi/2} (\cos\theta)^2 d\theta = \rho A r_{\text{loop}}^3 \left(\frac{\pi}{2}\right) = \frac{1}{2} \pi \rho A r_{\text{loop}}^3.$$

The total inertial moment is twice this magnitude:

$$I = \pi \rho A r_{\text{loop}}^3 = \frac{1}{2} m r_{\text{loop}}^2.$$

The torque and thus the angular acceleration is maximized when the magnetic moment is perpendicular to the magnetic field. The torque is then given by

$$\tau_{\text{max}} = |\vec{\mu} \times \vec{B}| = \mu B \sin\theta = \mu B = iAB = i\pi r_{\text{loop}}^2 B.$$

The angular acceleration is:

$$\alpha_{\text{max}} = \frac{\tau_{\text{max}}}{I} = \frac{i\pi r_{\text{loop}}^2 B}{\frac{1}{2} m r_{\text{loop}}^2} = \frac{2\pi i B}{m}.$$

The current is:

$$i = \frac{\Delta V}{R}.$$

The resistance of the wire making up the loop is

$$R = \frac{2\pi r_{\text{loop}} \rho_R}{A}.$$

CALCULATE: For this problem, it is instructive to calculate the various quantities separately and then combine the intermediate results to get the maximum angular acceleration of the loop. The mass of the loop is

$$m = 2\pi r_{\text{loop}} A \rho = 2\pi (8960 \text{ kg/m}^3) (1.00 \cdot 10^{-5} \text{ m}^2) (0.500 \text{ m}) = 0.2814867 \text{ kg}.$$

The resistance of the wire making up the loop is

$$R = \frac{2\pi r_{\text{loop}} \rho_R}{A} = \frac{2\pi (0.500 \text{ m}) (16.78 \cdot 10^{-9} \Omega \text{ m})}{1.00 \cdot 10^{-5} \text{ m}^2} = 0.00527159 \Omega.$$

The current in the loop is $i = \frac{\Delta V}{R} = \frac{0.0120 \text{ V}}{0.00527159 \Omega} = 2.27635 \text{ A}$.

The maximum angular acceleration is $\alpha_{\text{max}} = \frac{2\pi i B}{m} = \frac{2\pi (2.27635 \text{ A}) (0.250 \text{ T})}{0.2814867 \text{ kg}} = 12.702857 \text{ rad/s}^2$.

ROUND: The result is reported to three significant figures. The maximum angular acceleration is $\alpha_{\text{max}} = 12.7 \text{ rad/s}^2$.

DOUBLE-CHECK: The mass of the loop, the current in the loop, and the resistance of the loop are reasonable and all have the correct units.

27.52.

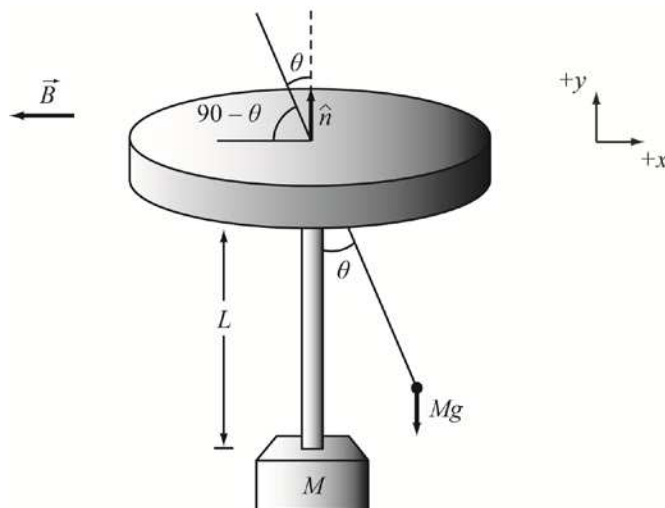

The torque on the coil as a function of θ is $\tau = |\vec{\mu} \times \vec{B}| = \mu B \sin(90^\circ - \theta) = \mu B \cos \theta$. The magnetic moment of the coil is $\mu = NiA$. Assume the coil contributes little to the inertial moment of the galvanometer. Assume the mass is distributed evenly through the rod. The torque on the rod due to gravity is:

$$\tau = |\vec{r} \times \vec{F}| = LF \sin \theta = LMg \sin \theta,$$

where r is the distance to the center of mass of the rod. Equating the two torques gives:

$$\mu B \cos \theta = LMg \sin \theta \Rightarrow \tan \theta = \frac{\mu B}{LMg} = \frac{NiAB}{LMg} \Rightarrow \theta = \tan^{-1} \left(\frac{NiAB}{LMg} \right).$$

- 27.53. Assume the electron orbits the hydrogen with speed, v . The current of the electron going around its orbit is:

$$i = \frac{q}{t} = -\frac{e}{d/v} = -\frac{ev}{d} = -\frac{ev}{2\pi r}.$$

The magnetic moment of the orbit is: $\mu = iA = i\pi r^2 = -\frac{ev}{2\pi r}(\pi r^2) = -\frac{1}{2}evr$. Angular momentum is given by $L = rp = rmv$. Using the angular momentum, the moment is:

$$\vec{\mu} = -\frac{1}{2}er\vec{v} = -\frac{1}{2}e\left(\frac{m}{m}\right)r\vec{v} = -\frac{erm\vec{v}/2}{m} = -\frac{e\vec{L}}{2m}.$$

- 27.54. **THINK:** The magnetic field produces a torque on the coil. This stretches the spring until it creates a torque equal but opposite to the torque due to the magnetic field. The ring has a diameter of $d = 0.0800$ m and carries a current of $i = 1.00$ A. The spring constant is $k = 100$. N/m and the magnetic field is $B = 2.00$ T.

SKETCH:

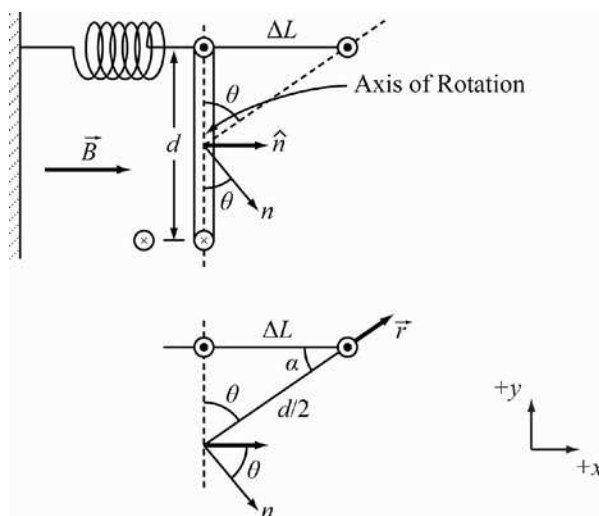

RESEARCH: The torque due to the spring is $\tau = \vec{r} \times \vec{F}_s$. The torque due to the magnetic field is $\tau = iAB \sin \theta$.

SIMPLIFY: The angle θ is given by: $\sin \theta = \frac{\Delta L}{d/2} = \frac{2\Delta L}{d}$. The torque due to the spring is $\tau_s = \vec{r} \times \vec{F}_s = dk\Delta L \sin \theta / 2$. Equating this to the torque due to the magnetic field gives:

$$dk\Delta L \cos \theta / 2 = iAB \sin \theta \Rightarrow \Delta L = \frac{2iAB}{dk} = \frac{2i(\pi d^2 / 4)B}{dk} = \frac{i\pi dB}{2k}.$$

CALCULATE: $\Delta L = \frac{(1.00 \text{ A})\pi(0.0800 \text{ m})(2.00 \text{ T})}{2(100. \text{ N/m})} = 0.002513274 \text{ m}$

ROUND: The values are given to three significant figures, thus the extension is $\Delta L = 2.51$ mm.

DOUBLE-CHECK: This result is reasonable.

- 27.55. **THINK:** The coil experiences a torque due to the magnetic field. The coil, however, is hinged along one of its lengths. The torque then can be determined in the normal way. The force on each segment is calculated to determine the torque on the coil. The coil has $N = 40$, a width of $w = 16.0$ cm, a height of $h = 30.0$ cm and carries a current of 0.200 A. The magnetic field is $\vec{B} = (0.0650\hat{x} + 0.250\hat{z})$ T.

SKETCH:

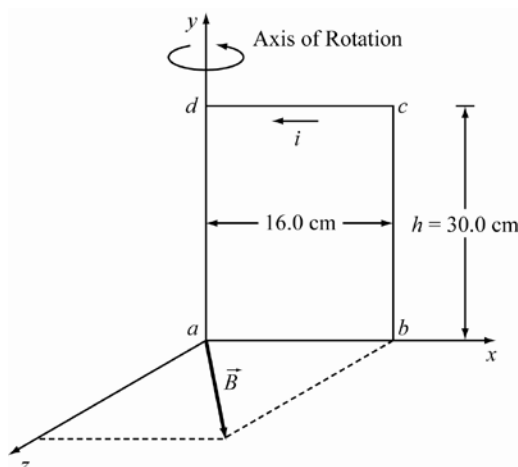

RESEARCH: The force on a length of wire carrying current in a magnetic field is $\vec{F} = Ni\vec{l} \times \vec{B}$. The torque is given by $\tau = \vec{r} \times \vec{F}$.

SIMPLIFY: The force on the segment $a-b$ is $\vec{F}_{ab} = Nil_{ab}\hat{x} \times [B_x\hat{x} + B_z\hat{z}] = NiwB_z(\hat{x} \times \hat{z}) = -Niwb_z\hat{y}$. The force on the segment $b-c$ is:

$$\vec{F}_{bc} = Nil_{bc}\hat{y} \times [B_x\hat{x} + B_z\hat{z}] = Nih[B_x(\hat{y} \times \hat{x}) + B_z(\hat{y} \times \hat{z})] = Nih[B_x(-\hat{z}) + B_z(\hat{x})] = Nih[-B_x\hat{z} + B_z\hat{x}]$$

The net force on the coil is zero since the magnetic field does no work. The coil is free to rotate about the y -axis. The only force that can contribute is F_{bc} : $\tau = \vec{r} \times \vec{F} = w\hat{x} \times \vec{F}_{bc} = w\hat{x} \times Nih[-B_x\hat{z} + B_z\hat{x}] = wNihB_x\hat{y}$. The door rotates counterclockwise when looking from the top.

CALCULATE: $\vec{F}_{ab} = -(40)(0.200 \text{ A})(0.160 \text{ m})(0.250 \text{ T})\hat{y} = -0.320\hat{y} \text{ N}$

$$\vec{F}_{bc} = (40)(0.200 \text{ A})(0.300 \text{ m})[(-0.0650 \text{ T})\hat{z} + (0.250 \text{ T})\hat{x}] = (-0.156\hat{z} + 0.600\hat{x}) \text{ N} = (0.600\hat{x} - 0.156\hat{z}) \text{ N}$$

$$\tau = (40)(0.200 \text{ A})(0.160 \text{ m})(0.300 \text{ m})(0.0650 \text{ T})\hat{y} = 0.02496\hat{y} \text{ N m}$$

ROUND:

(a) The force on segment $a-b$ is $\vec{F}_{ab} = -0.320\hat{y} \text{ N}$

(b) The force on segment $b-c$ is $\vec{F}_{bc} = (0.600\hat{x} - 0.156\hat{z}) \text{ N}$ or $|F_{bc}| = 0.620 \text{ N}$ directed 14.6° from the x -axis toward the negative z -axis.

(c) The total force is $F_{\text{net}} = 0$.

(d) The torque on the coil is $|\tau| = 0.0250 \text{ N m}$ and rotates along the y -axis in counterclockwise fashion.

(e) The coil rotates in a counterclockwise fashion as seen from above.

DOUBLE-CHECK: This result is reasonable.

$$\tau = NiAB \sin \theta = 40(0.200 \text{ A})(0.160 \text{ m})(0.300 \text{ m}), \sqrt{(0.0650 \text{ T})^2 + (0.250 \text{ T})^2} \sin(14.6^\circ) = 0.0250 \text{ N m}$$

27.56. The Hall voltage is given by: $\Delta V_{\parallel} = \frac{iB}{neh}$. The carrier density of the electron sheet is:

$$n = \frac{iB}{eh\Delta V_{\parallel}} = \frac{10.0 \cdot 10^{-6} (1.00 \text{ T})}{(1.60 \cdot 10^{-19} \text{ C})(10.0 \cdot 10^{-9} \text{ m})(0.680 \cdot 10^{-3} \text{ V})} = 9.19 \cdot 10^{24} \text{ e/m}^3$$

27.57. **THINK:** The question asks for the carrier density of the thin film, and the nature of the carriers. The film has a thickness of $h = 1.50 \mu\text{m}$. The current is $i = 12.3 \text{ mA}$ and the voltage reads $V = -20.1 \text{ mV}$. The magnetic field is $B = 0.900 \text{ T}$.

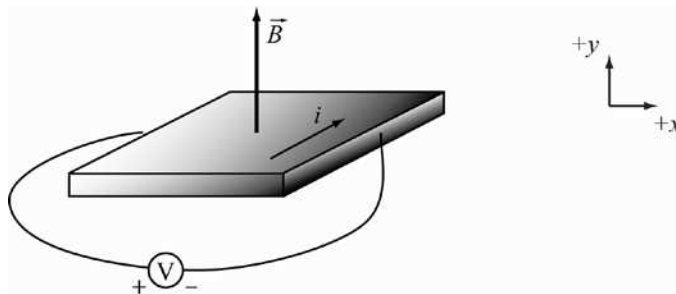
SKETCH:**RESEARCH:**

(a) Due to the magnetic force, the charge carriers are accumulated on the visible edge of the sample. Since the polarity of the Hall potential is negative, the charge carriers are holes.

(b) The Hall voltage magnitude is given by $\Delta V_H = \frac{iB}{neh}$.

SIMPLIFY:

(b) The charge carrier density is $n = \frac{iB}{he\Delta V_H}$.

CALCULATE:

$$(b) n = \frac{12.3 \cdot 10^{-3} (0.900 \text{ T})}{(1.50 \cdot 10^{-6} \text{ m})(1.602 \cdot 10^{-19} \text{ C})(20.1 \cdot 10^{-3} \text{ V})} = 2.2919 \cdot 10^{24} \text{ holes/m}^3$$

ROUND:

(b) The values are given to three significant figures, so the carrier density of the film is $n = 2.29 \cdot 10^{24} \text{ holes/m}^3$.

DOUBLE-CHECK: This is a reasonable value for a carrier density.

27.58. The radius of the proton's path is: $r = \frac{mv}{qB} = \frac{m}{qB} \left(\frac{2\pi r}{T} \right) = \frac{m}{qB} \left(\frac{2\pi r}{1/f} \right) = \frac{2\pi mrf}{qB}$. The radius of the path and

its frequency are: $r = \frac{mv}{qB}$ and $f = \frac{qB}{2\pi m}$, respectively. In the cyclotron:

$$r = \frac{(1.67 \cdot 10^{-27} \text{ kg})(2.998 \cdot 10^8 \text{ m/s})/2}{(1.602 \cdot 10^{-19} \text{ C})(9.00 \text{ T})} = 0.1736 \text{ m} \approx 0.174 \text{ m},$$

$$f = \frac{(1.602 \cdot 10^{-19} \text{ C})(9.00 \text{ T})}{2\pi(1.67 \cdot 10^{-27} \text{ kg})} = 1.374 \text{ MHz} \approx 1.37 \text{ MHz}.$$

In the Earth's magnetic field:

$$r = \frac{(1.67 \cdot 10^{-27} \text{ kg})(2.998 \cdot 10^8 \text{ m/s})/2}{(1.602 \cdot 10^{-19} \text{ C})(0.500 \text{ G})(0.0001 \text{ T/G})} = 31.25 \text{ km} \approx 31.3 \text{ km},$$

$$f = \frac{(1.602 \cdot 10^{-19} \text{ C})(0.500 \cdot 10^{-4} \text{ T})}{2\pi(1.67 \cdot 10^{-27} \text{ kg})} = 0.7634 \text{ kHz} \approx 0.763 \text{ kHz}.$$

27.59. The force on the wire is:

$$F = i\vec{L} \times \vec{B} = iLB \sin\theta = (3.41 \text{ A})(0.100 \text{ m})(0.220 \text{ T})\sin(90.0^\circ - 10.0^\circ) = 0.07388 \text{ N} \approx 7.39 \cdot 10^{-2} \text{ N}.$$

- 27.60. The radius of a charged particle's path in a magnetic field is $r = mv / |q|B$. For this electron, the radius of its path is:

$$r = \frac{(9.109 \cdot 10^{-31} \text{ kg})(6.00 \cdot 10^7 \text{ m/s})}{(1.602 \cdot 10^{-19} \text{ C})(0.500 \cdot 10^{-4} \text{ T})} = 6.82 \text{ m}.$$

- 27.61. The force on a current carrying wire in a magnetic field is $F = i l B \sin \theta$. To determine the minimum current, set $\theta = 90^\circ$:

$$i = \frac{F}{lB} = \frac{1.00 \text{ N}}{0.100 \text{ m}(0.430 \cdot 10^{-4} \text{ T})} = 232,558 \text{ A} \approx 2.33 \cdot 10^5 \text{ A}.$$

The minimum current required for the wire to experience a force of 1.0 N is $i = 2.33 \cdot 10^5 \text{ A}$.

- 27.62. The torque on a current carrying coil in a magnetic field is:

$$\begin{aligned} \tau &= NiAB \sin \theta \\ &= (100)(100 \cdot 10^{-3} \text{ A})\pi(0.100 \text{ m})^2(0.0100 \text{ T})(\sin 30.0^\circ) \\ &= 0.0015707 \text{ N m} \approx 1.57 \cdot 10^{-3} \text{ N m}. \end{aligned}$$

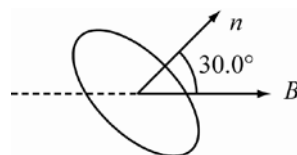

- 27.63. (a) The electron must travel in a circular path with a radius of 60.0 cm, as shown in the figure below.

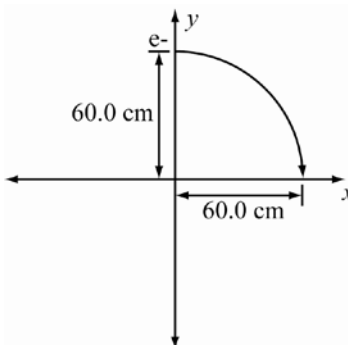

By the right-hand rule, B must be in the negative z -direction.

$$B = \frac{mv}{q_e r} = \frac{(9.11 \cdot 10^{-31} \text{ kg})(2.00 \cdot 10^5 \text{ m/s})}{(1.60 \cdot 10^{-19} \text{ C})(0.600 \text{ m})} = 1.89 \cdot 10^{-6} \text{ T}$$

- (b) The magnetic force is perpendicular to the motion and does no work.
 (c) Since the speed of an electron does not change, the time the electron takes to travel a quarter-circle is given by:

$$t = \frac{\pi r}{2v} = \frac{3.14159(0.600 \text{ m})}{2(2.00 \cdot 10^5 \text{ m/s})} = 4.71 \cdot 10^{-6} \text{ s}.$$

- 27.64. **THINK:** First, determine the current using Ohm's law and then determine the force on the wire.
SKETCH:

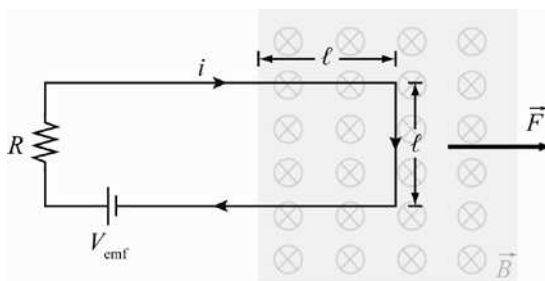

RESEARCH: Ohm's law is $V = iR$. Use the values: $V = 12.0 \text{ V}$, $B = 5.00 \text{ T}$, and $R = 3.00 \Omega$. $\vec{F} = i\vec{L} \times \vec{B}$. In this case, since the top and bottom part of the loop have currents traveling in opposite directions, their forces will cancel. Only the right side of the loop will contribute to the force.

SIMPLIFY: $F = ilB$, to the right (from the right-hand rule), $V = iR \Rightarrow i = V/R$. Substitute the expression for I into the expression for F to get: $F = VIB/R$.

CALCULATE: $F = \frac{12.0 \text{ V}}{3.00 \Omega} (1.00 \text{ m})(5.00 \text{ T}) = 20.0 \text{ N}$

ROUND: $F = 20.0 \text{ N}$ to the right.

DOUBLE-CHECK: The final expression makes sense since it is expected that if a larger voltage is applied, a larger force is attained.

- 27.65. **THINK:** As the alpha particle enters the region of the magnetic field, its motion will be deflected into a curved path. The radius of curvature is determined by the mass, charge, and initial velocity, and by the strength of the field. All quantities are given except for the velocity. The particle's velocity can be determined by employing the law of conservation of energy. The period of revolution can be determined from the particle's radius of curvature and velocity. $m_\alpha = 6.64 \cdot 10^{-27} \text{ kg}$, $q_\alpha = +2e$, $\vec{B} = 0.340 \text{ T}$, and $\Delta V = 2700 \text{ V}$.

SKETCH:

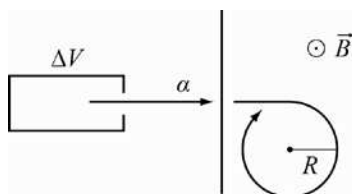

RESEARCH: The radius of curvature is given by $r = mv/|q|B$. By conservation of kinetic energy, $|q|V = \frac{1}{2}mv^2$. The period of revolution is given by $T = \frac{2\pi r}{v}$.

SIMPLIFY: $|q|V = \frac{1}{2}mv^2 \Rightarrow v = \sqrt{\frac{2|q|V}{m}}$

CALCULATE: $r = \frac{(6.64 \cdot 10^{-27} \text{ kg})(5.105 \cdot 10^5 \text{ m/s})}{2|1.602 \cdot 10^{-19} \text{ C}|0.340 \text{ T}} = 0.03111 \text{ m}$

$v = \sqrt{\frac{2|2(1.602 \cdot 10^{-19} \text{ C})|2700}{6.64 \cdot 10^{-27} \text{ kg}}} = 5.105 \cdot 10^5 \text{ m/s}$

$T = \frac{2\pi(0.03111 \text{ m})}{5.105 \cdot 10^5 \text{ m/s}} = 3.829 \cdot 10^{-7} \text{ s}$

ROUND: Rounding to three significant figures, $r = 0.0311 \text{ m}$ and $T = 3.83 \cdot 10^{-7} \text{ s}$.

DOUBLE CHECK: All calculated values have the correct units. The numerical values are appropriate to the scale of the particle.

27.66. THINK: The electric field component and the vertical component must cancel each other.

SKETCH: Not necessary.

RESEARCH: It is required that $\vec{v} \times \vec{B} = -\vec{E} \Rightarrow (\vec{v} \times \vec{B}) \cdot \vec{B} = -\vec{E} \cdot \vec{B} \Rightarrow 0 = \vec{E} \cdot \vec{B}$ (since for any vector, $(\vec{A} \times \vec{B}) \cdot \vec{B} = 0$). But since \vec{E} is not perpendicular to \vec{B} , $\vec{E} \cdot \vec{B} \neq 0$. Note that $\vec{E} = -150 \hat{z}$ N/C and $\vec{B} = (50.0 \hat{y} - 20.0 \hat{z})$ T. This scenario cannot occur.

SIMPLIFY: Nothing to simplify.

CALCULATE: No calculations are necessary.

ROUND: There are no values to round.

DOUBLE-CHECK: No Lorentz force can counteract an electric force in z -direction, if the particle is also traveling in z -direction, because the Lorentz force is always perpendicular to the velocity vector.

27.67. THINK: Determine the velocity in terms of the mass and see how this changes the answer.

SKETCH: Not necessary.

RESEARCH: $v = qBr / m$, $B = 0.150$ T, $r = 0.0500$ m and $m = 6.64 \cdot 10^{-27}$ kg.

SIMPLIFY: It is not necessary to simplify.

CALCULATE: $v = \frac{(1.602 \cdot 10^{-19} \text{ C})(0.150 \text{ T})(0.0500 \text{ m})}{6.64 \cdot 10^{-27} \text{ kg}} = 1.809 \cdot 10^5 \text{ m/s}$

Note that for $m' = \frac{3}{4}m$, $v' = \frac{qBr}{3m/4} = \frac{4}{3}v$; the velocity increases by a factor of $4/3$.

ROUND: $v = 1.81 \cdot 10^5$ m/s

DOUBLE-CHECK: Since there is an inverse relationship between v and m , it makes sense that decreasing m by a factor of $3/4$ increases v by factor of $(3/4)^{-1} = 4/3$.

27.68. THINK: First determine the radius of curvature and then determine the amount the electron deviates over a distance of $l = 1.00$ m. Use $B = 0.300$ G as the Earth's magnetic field. Convert the energy into Joules.

SKETCH:

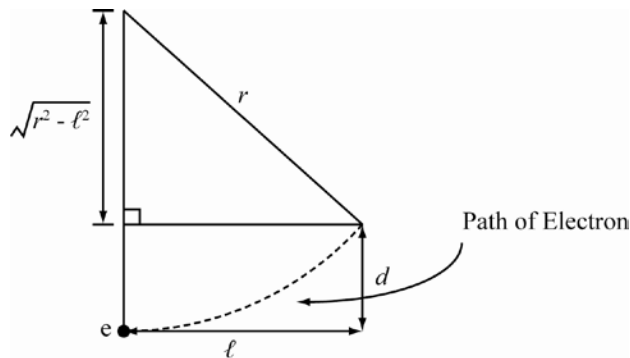

The dashed line is the path of the electron.

RESEARCH: Geometry gives $d = r - \sqrt{r^2 - l^2}$. $r = \frac{mv}{qB} = \frac{p}{qB} = \frac{\sqrt{2mE}}{qB}$, $E = 7500$ eV ($1.609 \cdot 10^{-19}$ J/eV).

SIMPLIFY: It is not necessary to simplify.

CALCULATE: $r = \frac{\sqrt{2(9.11 \cdot 10^{-31} \text{ kg})(7.50 \cdot 10^3 \text{ eV})(1.602 \cdot 10^{-19} \text{ J/eV})}}{(1.602 \cdot 10^{-19} \text{ C})(0.300 \cdot 10^{-4} \text{ T})} = 9.7354 \text{ m}$

$$d = (9.7354 \text{ m}) - \sqrt{(9.7354 \text{ m})^2 - (1.00 \text{ m})^2} = 0.051495 \text{ m, upward from the ground.}$$

ROUND: To three significant figures, the answer should be rounded to: $d = 0.0515 \text{ m}$ upward.

DOUBLE-CHECK: Note that $d \ll 1.00 \text{ m}$, as is expected since the magnetic field of the Earth is fairly weak.

- 27.69. THINK:** Since the electric field from the plates will cause the proton to move in the negative y -direction, the magnetic field must apply a force in the positive y -direction. It is determined from the right-hand rule that \vec{B} must be in the negative z -direction.

SKETCH:



RESEARCH: $v = 1.35 \cdot 10^6 \text{ m/s}$, $V = 200. \text{ V}$, $d = 35.0 \cdot 10^{-3} \text{ m}$, and $E = V / d$. It is required that $vB = E$.

SIMPLIFY: $B = \frac{E}{v} = \frac{V}{vd}$

CALCULATE: $B = \frac{(200. \text{ V})}{(1.35 \cdot 10^6 \text{ m/s})(35.0 \cdot 10^{-3} \text{ m})} = 4.23 \cdot 10^{-3} \text{ T}$

ROUND: To three significant figures, $B = -4.23 \cdot 10^{-3} \hat{z} \text{ T}$

DOUBLE-CHECK: The final expression for B makes sense. If the applied voltage is larger, one needs a larger magnetic field.

- 27.70. THINK:** Determine the radius of curvature. This distance will allow the electron to be trapped in the field.

SKETCH:

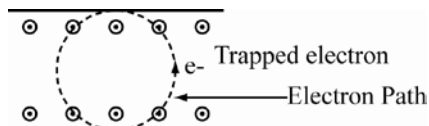

RESEARCH: The magnitude is given by $F_B = qv_0B$, in the positive y -direction (by the right-hand rule).

$$d = r = \frac{mv_0}{|q|B}$$

SIMPLIFY: $v_0 = \frac{eBd}{m}$

CALCULATE: Not applicable.

ROUND: Not applicable.

DOUBLE-CHECK: It makes sense that for larger magnetic fields and for larger widths, the escape velocity is larger.

- 27.71. **THINK:** Equilibrium occurs when the net torque on the coil is zero. Use the values: $A = d^2$, $d = 0.200$ m, $i = 5.00$ A, $m = 0.250$ kg, $B = 0.00500$ T, and $N = 30$.

SKETCH:

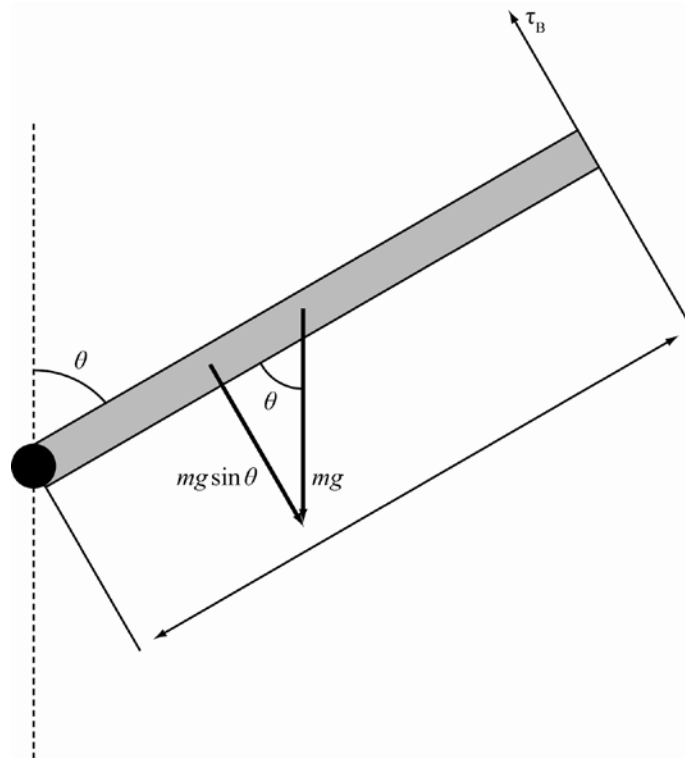

RESEARCH: $\tau_g = mg \sin \theta (d/2)$, $\tau_B = NiAB \cos \theta$. It is required that $\tau_g = \tau_B$.

SIMPLIFY: $\tau_g = \tau_B \Rightarrow \frac{1}{2} mgd \sin \theta = Nid^2 B \cos \theta$

$$\frac{\sin \theta}{\cos \theta} = \frac{2NdiB}{mg} \Rightarrow \tan \theta = \frac{2NdiB}{mg} \Rightarrow \theta = \tan^{-1} \left(\frac{2NdiB}{mg} \right)$$

CALCULATE: $\theta = \tan^{-1} \left[\frac{2(30)(0.200 \text{ m})(5.00 \text{ A})(0.00500 \text{ T})}{(0.250 \text{ kg})(9.81 \text{ m/s}^2)} \right] = 6.9740^\circ$

ROUND: The number of turns is precise, so it does not limit the precision of the answer. The rest of the values are given to three significant figures of precision, so it is appropriate to round the final answer to: $\theta = 6.97^\circ$.

DOUBLE-CHECK: It makes sense that θ is inversely proportional to m , since the less the coil weighs, the more vertical it must be.

- 27.72. **THINK:** It can be deduced from symmetry that the net force is in the negative y -direction. Therefore, $F_B = F_y$.

SKETCH:

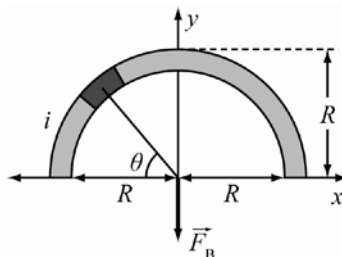

RESEARCH: From the book, $F_B = iLB\sin\theta$. The objective is to sum up the forces due to each point of the semi-circle. This means we will integrate F_B over the length of the wire.

SIMPLIFY: $F_y = \int_0^{\pi} iLB\sin\theta dL = \int_0^{\pi} iLB\sin\theta (Rd\theta) = iLBR \int_0^{\pi} \sin\theta d\theta$ in the negative y -direction.

CALCULATE: $F_y = iLBR \cos\theta \Big|_0^{\pi} = -iLBR(-1-1) = 2iLBR$ in the negative y -direction.

ROUND: Not applicable.

DOUBLE-CHECK: Note that $F_x = \int_0^{\pi} iR\cos\theta B d\theta = 0$. This confirms the analysis based on symmetry.

- 27.73. **THINK:** The magnetic force on the proton due to the presence of the magnetic field will affect only the component of the proton's velocity that is perpendicular to the magnetic field.

SKETCH:

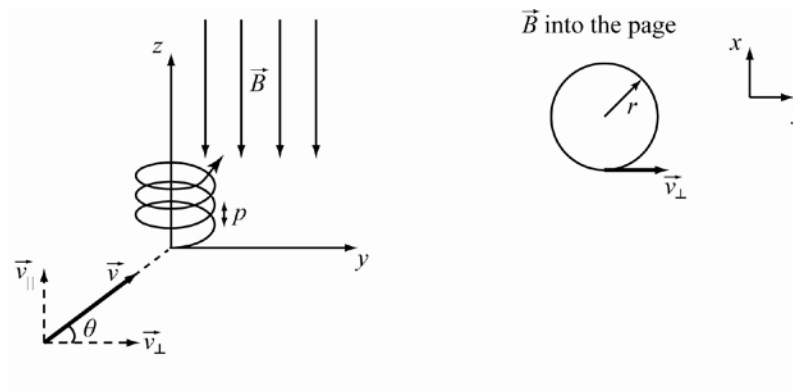

Note: Take region of magnetic field as $y > 0$.

RESEARCH:

(a) When the proton enters the magnetic field, the component of its velocity that is parallel to the field will be unaffected, so the proton advances along the z -axis at a constant speed. The component of the particle's velocity that is perpendicular to the field will be forced into a circular path in the xy -plane. Thus, the trajectory of the proton will be a helix, as shown in the figure. The magnetic force on the proton is given by:

$$\vec{F}_B = q\vec{v} \times \vec{B} = q(\vec{v}_{\parallel} + \vec{v}_{\perp}) \times \vec{B} = q\vec{v}_{\parallel} \times \vec{B} + q\vec{v}_{\perp} \times \vec{B} = q\vec{v}_{\perp} \times \vec{B}.$$

(b) The magnitude of the magnetic force is given by $|\vec{F}_B| = |q\vec{v}_{\perp} \times \vec{B}| = qv_{\perp}B$. By Newton's Second Law, $|\vec{F}_B| = ma \Rightarrow qv_{\perp}B = mv_{\perp}^2/r$.

(c) The period of the circular motion in the xy -plane projection is given by $T = \frac{2\pi r}{v_{\perp}}$. The frequency is given by $f = 1/T$.

(d) The pitch of the motion is $p = v_{\parallel}T$.

SIMPLIFY:

(b) The radius of the trajectory projected onto the xy -plane is given by

$$r = \frac{mv_{\perp}}{qB} = \frac{mv \sin(90^{\circ} + \theta)}{qB} = \frac{mv \cos \theta}{qB}.$$

$$(c) T = \frac{2\pi \left(\frac{mv_{\perp}}{qB} \right)}{v_{\perp}} = \frac{2\pi m}{qB}.$$

(d) $p = (v \sin \theta)T$.

CALCULATE:

$$(b) r = \frac{(1.67 \cdot 10^{-27} \text{ kg})(1.00 \cdot 10^6 \text{ m/s}) \cos(60.0^{\circ})}{(1.60 \cdot 10^{-19} \text{ C})(0.500 \text{ T})} = 10.44 \text{ mm}.$$

$$(c) T = \frac{2\pi(1.67 \cdot 10^{-27} \text{ kg})}{(1.60 \cdot 10^{-19} \text{ C})(0.500 \text{ T})} = 1.312 \cdot 10^{-7} \text{ s}, \quad f = \frac{1}{(1.312 \cdot 10^{-7} \text{ s})} = 7.624 \cdot 10^6 \text{ Hz}.$$

$$(d) p = (1.00 \cdot 10^6 \text{ m/s}) \sin(60.0^{\circ})(1.312 \cdot 10^{-7} \text{ s}) = 113.6 \text{ mm}.$$

ROUND: Rounding to three significant figures,

(b) 10.4 mm

(c) $T = 1.31 \cdot 10^{-7} \text{ s}$, $f = 7.62 \cdot 10^6 \text{ Hz}$

(d) 114 mm

DOUBLE CHECK: All calculated values have correct units. The magnitudes are appropriate for subatomic particles.

Multi-Version Exercises

Exercises 27.74–27.76 For the ball to travel in a circle with radius r , we have $r = \frac{mv}{|q|B}$.

$$27.74. \quad r = \frac{mv}{|q|B}$$

$$B = \frac{mv}{|q|r} = \frac{(5.063 \cdot 10^{-3} \text{ kg})(3079 \text{ m/s})}{(11.03 \text{ C})(2.137 \text{ m})} = 0.6614 \text{ T}$$

$$27.75. \quad r = \frac{mv}{|q|B}$$

$$m = \frac{r|q|B}{v} = \frac{(2.015 \text{ m})(11.17 \text{ C})(0.8000 \text{ T})}{3131 \text{ m/s}} = 0.005751 \text{ kg} = 5.751 \text{ g}$$

$$27.76. \quad r = \frac{mv}{|q|B}$$

$$|q| = \frac{mv}{rB} = \frac{(3.435 \cdot 10^{-3} \text{ kg})(3183 \text{ m/s})}{(1.893 \text{ m})(0.5107 \text{ T})} = 11.31 \text{ C}$$

Exercises 27.77–27.79 The electric force is given by $F_E = qE$. The magnetic force is given by $F_B = vBq$. Setting these forces equal to each other gives us

$$qE = vBq$$

$$v = \frac{E}{B}$$

27.77. $v = \frac{E}{B} = \frac{1.749 \cdot 10^4 \text{ V/m}}{46.23 \cdot 10^{-3} \text{ T}} = 3.783 \cdot 10^5 \text{ m/s}$.

27.78. $v = \frac{E}{B}$
 $B = \frac{E}{v} = \frac{2.207 \cdot 10^4 \text{ V/m}}{4.713 \cdot 10^5 \text{ m/s}} = 0.04683 \text{ T} = 46.83 \text{ mT}$

27.79. $v = \frac{E}{B}$
 $E = vB = (5.616 \cdot 10^5 \text{ m/s})(47.45 \cdot 10^{-3} \text{ T}) = 2.665 \cdot 10^4 \text{ V/m}$

Chapter 28: Magnetic Fields of Moving Charges

Concept Checks

28.1. c 28.2. a 28.3. a 28.4. b 28.5. e 28.6. d 28.7. d 28.8. d

Multiple-Choice Questions

28.1. b 28.2. c 28.3. c 28.4. a 28.5. d 28.6. a 28.7. c 28.8. c 28.9. a 28.10. d 28.11. a 28.12. a 28.13. d
28.14. b

Conceptual Questions

- 28.15. The wires are twisted in order to cancel out the magnetic fields generated by these wires.
- 28.16. Since the currents running through the wire generate magnetic fields, these fields may overpower the magnetic field of the Earth and make the compass give a false direction.
- 28.17. No, an ideal solenoid cannot exist, since we cannot have an infinitely long solenoid. To a certain extent, yes, it renders the derivation void. However, the derivation is an approximation and is an important theoretical example.
- 28.18. In Example 28.1, the right hand rule implies that the magnetic dipole of the loop points out of the page. Application of the right hand rule to the straight wire tells us that the magnetic field produced by wire points out of the page. Assume the angle between the dipole moment and the field remains fixed. Since the dipole strength is also constant, the only quantity left to vary is field strength. If the potential energy is to be reduced, the loop must move towards a region of smaller magnetic field strength. That is, the loop must move away from the straight current-carrying wire.
- 28.19. By Coulomb's Law, the electric force between the particles has magnitude $|F_e| = q^2 / (4\pi\epsilon_0 d^2)$. For the magnetic force, the version of the Biot-Savart Law given in the text can be adapted to describe the magnetic field produced by a moving particle via the replacement $I dl \Rightarrow (dq/dt) dl \Rightarrow dq(dl/dt) \Rightarrow qv_s$ with q charge and v_s , the velocity of the source particle. The magnetic field produced by one particle at the location of the other can be written as $B = \mu_0 qvd / (4\pi d^3)$ with v , common velocity and d , the separate of the particles. The magnitude of the magnetic force one particle is given by $|F_m| = |qvB| = (\mu_0 / (4\pi)) |qv \cdot (qvd) / d^3| = \mu_0 q^2 v^2 / (4\pi d^2)$. Since the vectors v , d and $v \cdot d$ are mutually perpendicular (the site of the angle between any two of them is unity) the ratio of forces is $|F_m / F_e| = \mu_0 \epsilon_0 v^2$ which also $|F_m / F_e| = v^2 / c^2$, where c is the speed of light.
- 28.20. The field is given by Ampere's law $B(2\pi)(a+b)/2 = \mu_0 i_{\text{enc}}$. Current density is then given by:

$$J = i / (\pi(b^2 - a^2))$$

The area of interest is:

$$\pi \left[\frac{(a+b)}{2} \right]^2 = A$$

$$B(2\pi) \left[\frac{(a+b)}{2} \right] = \mu_0 AJ$$

$$\begin{aligned}
 B &= \frac{\mu_0}{\pi(a+b)} \pi \left[\left(\frac{a+b}{2} \right)^2 - a^2 \right] \cdot \frac{i}{\pi(b^2 - a^2)} \\
 &= \frac{\mu_0 i}{\pi(a+b)} \cdot \frac{\left(\frac{a+b}{2} \right)^2 - a^2}{(b^2 - a^2)}.
 \end{aligned}$$

- 28.21.** The magnetic field at point P would be zero. The contribution from part A would be zero since P lies along the axis of A. The currents through B and C points in opposite directions and yield magnetic fields that cancel out at P .
- 28.22.** Ampere's law states that, $\oint_C B dl = \mu_0 i$, but since B is constant the integral must be zero. If so, i is zero everywhere and consequently $J = 0$ everywhere.
- 28.23.** (a) Since molecular hydrogen is diamagnetic, the molecules must have no intrinsic dipole moment. Since the nuclear spins cannot cancel the electron spins, the electron spins must be opposite to cancel each other. (b) With only a single electron, the hydrogen atoms must have an intrinsic magnetic moment. Atomic hydrogen gas, if it could be maintained, would have to exhibit paramagnetic or ferromagnetic behavior. But ferromagnetism would require inter atomic interactions strong enough to align the atoms in domains, which is not consistent with the gaseous state. Hence one would expect atomic hydrogen to be paramagnetic.
- 28.24.** The saturation of magnetizations for paramagnetic and ferromagnetic materials is of comparable magnitude. In both types of materials the intrinsic magnetic moments of the atoms arise from a few unpaired electron spins. Magnetization effects in ferromagnetic materials are more pronounced at low applied fields because the atoms come pre-aligned in their domains, but once both types of atoms have been forced into essentially uniform alignment, the magnetization they produce is comparable. For either type of material maximum magnetizations of order $10^6 \text{ A m}^2 / \text{m}^3 = 10^6 \text{ A/m}$ magnetic dipole moment per unit volume are typical.
- 28.25.** The wire carries a current which produces a magnetic field. This magnetic field will deflect the electron by the Lorentz force in the left direction.
- 28.26.** Each side of the loop will create the same magnetic field at the center of the loop. The total field is 4 times the field of one side. The field at the center is given by the Biot-Savart Law:

$$|d\vec{B}| = \left| \frac{\mu_0 i}{4\pi} \frac{d\vec{s} \times \vec{r}}{r^3} \right| = \frac{\mu_0 i}{4\pi r^2} \sin\theta ds.$$

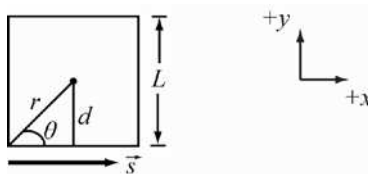

Since $\sin\theta = d/r$, the differential element of magnetic field is

$$dB = \frac{\mu_0 i}{4\pi} \frac{d}{r^3} ds = \frac{\mu_0 i d}{4\pi} \frac{ds}{(d^2 + s^2)^{3/2}}.$$

Integration gives

$$B = \frac{\mu_0 i d}{4\pi} \int_{-d}^d \frac{ds}{(d^2 + s^2)^{3/2}} = \frac{2\mu_0 i d}{4\pi} \int_0^d \frac{ds}{(d^2 + s^2)^{3/2}} = \frac{\mu_0 i d}{2\pi} \left[\frac{s}{d^2 \sqrt{d^2 + s^2}} \right]_0^d = \frac{\mu_0 i}{2\pi d} \frac{d}{\sqrt{2}d} = \frac{\mu_0 i}{2\sqrt{2}\pi d}.$$

The total field is then $B_{\text{tot}} = 4B = \frac{\sqrt{2}\mu_0 i}{\pi d} = \frac{\sqrt{2}\mu_0 i}{\pi(L/2)} = \frac{2\sqrt{2}\mu_0 i}{\pi L}$.

28.27.

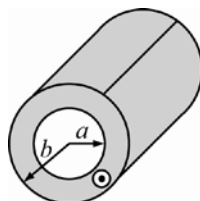

The current that flows through a ring of radius r which lies in the region $a < r < b$ is given by $i = \int J_0 dA = \int_a^r J_0 2\pi\rho d\rho = J_0 \pi\rho^2 \Big|_a^r = J_0 \pi(r^2 - a^2)$. To find the magnetic field employ Ampere's Law $\oint \vec{B} \cdot d\vec{s} = \mu_0 i_{\text{enclosed}}$. For a cylinder this becomes $B(2\pi r) = \mu_0 i_{\text{enc}}$ or $B = \mu_0 i_{\text{enc}} / (2\pi r)$. If $r < a$ then $B_{r < a} = 0$, thus if $a < r < b$ then $i_{\text{enc}} = J_0 \pi(r^2 - a^2)$ and $B_{a < r < b} = \frac{\mu_0 J_0 \pi(r^2 - a^2)}{2\pi r} = \frac{\mu_0 J_0 (r^2 - a^2)}{2r}$. If $r > b$ then $i_{\text{enc}} = J_0 \pi(b^2 - a^2)$ and $B_{r > b} = \frac{\mu_0 J_0 (b^2 - a^2)}{2r}$. Note that if $r = b$ then $B_{a < r < b} = \frac{\mu_0 J_0 (b^2 - a^2)}{2b} = B_{r > b}$.

28.28. The loop creates a magnetic field of $B_1 = \mu_0 i / (2R)$ at its center and is directed upwards. Out of the page. Both wires contribute a magnetic field of $B_w = \mu_0 i / (2\pi R)$ pointing out of the page. The total fields is then

$B_{\text{tot}} = B_1 + 2B_w = \frac{\mu_0 i}{2R} \left(1 + \frac{2}{\pi}\right)$, and points out of the page.

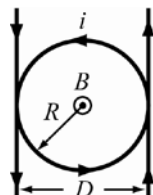

28.29. **THINK:** Ampere's Law can be used to determine the magnitude of the magnetic field in the two regions. **SKETCH:** A sketch is included at the end of the SIMPLIFY step, once the two equations have been found. **RESEARCH:** The current with the conductor is given by $i = \int J(r) dA$. The magnetic field is found using

Ampere's Law $\oint \vec{B} \cdot d\vec{s} = \mu_0 i_{\text{enclosed}}$ or $B = \frac{\mu_0 i_{\text{enc}}}{2\pi r}$.

SIMPLIFY: $i = \int J(r) dA = 2\pi \int_0^r J(r') r' dr' = 2\pi J_0 \int_0^r r' e^{-r'/R} dr' = 2\pi J_0 \left[-R(R+r')e^{-r'/R} \right]_0^r$
 $= \left((-R(R+r))e^{-r/R} - (-R(R+0))e^{-0/R} \right) 2\pi J_0$
 $= \left(R^2(1 - e^{-r/R}) - Rre^{-r/R} \right) 2\pi J_0$

If $r < R$ then $B_{r < R} = \frac{\mu_0}{2\pi r} \left[R^2 - R(R+r)e^{-r/R} \right] 2\pi J_0 = \frac{\mu_0 J_0}{r} \left[R^2 - R(R+r)e^{-r/R} \right]$.

If $r > R$ then $B_{r > R} = \frac{\mu_0}{2\pi r} \left[R^2 - R(R+R)e^{-R/R} \right] 2\pi J_0 = \frac{\mu_0 J_0}{r} \left[R^2 - 2R^2 e^{-1} \right] = \frac{\mu_0 J_0 R^2}{r} \left[1^2 - 2e^{-1} \right]$.

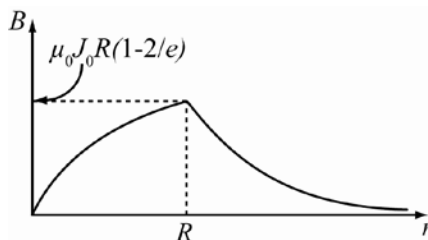

CALCULATE: There are no values to substitute.

ROUND: There are no values to round.

DOUBLE-CHECK: Note that the two computed formulas agree when $r = R$.

Exercises

28.30. The force of wire 1 on wire 2 is $F_{1 \rightarrow 2} = i_2 L B = i_2 L [\mu_0 i_1 / (2\pi d)] = \mu_0 i_1 i_2 L / (2\pi d)$. Since $2i_1 = i_2$,

$$F_{1 \rightarrow 2} = \mu_0 i_1^2 L / (\pi d). \text{ Solving for the current } i_1 \text{ gives } i_1 = \sqrt{\frac{\pi d F_{1 \rightarrow 2}}{\mu_0 L}} = \sqrt{\frac{\pi (0.0030 \text{ m})(7.0 \cdot 10^{-6} \text{ N})}{(4\pi \cdot 10^{-7} \text{ T m/A})(1.0 \text{ m})}} = 0.23 \text{ A}.$$

The current on the other wire is $i_2 = 0.46 \text{ A}$.

28.31. The magnetic field created by the wire is given by the Biot-Savart Law $B = \mu_0 i / (2\pi r)$. The force on the electron is given by the Lorentz force $F = qvB = qv\mu_0 i / (2\pi r)$. The acceleration of the electron is

$$a = \frac{F}{m} = \frac{qv\mu_0 i}{2\pi m r} = \frac{(1.602 \cdot 10^{-19} \text{ C})(4.0 \cdot 10^5 \text{ m/s})(4\pi \cdot 10^{-7} \text{ T m/A})(15 \text{ A})}{2\pi (9.109 \cdot 10^{-31} \text{ kg})(0.050 \text{ m})} = 4.2 \cdot 10^{12} \text{ m/s}^2$$

The direction of the acceleration is radially away from the wire.

28.32. The magnitude of the magnetic field created by a moving charge along its line of motion is zero. By the Biot-Savart Law,

$$\vec{B} = \frac{\mu_0}{4\pi} \frac{id\vec{s} \times \hat{r}}{r^2} = \frac{\mu_0}{4\pi} \frac{qd\vec{v} \times \hat{r}}{r^2} = 0,$$

since the angle between the angle between the velocity and the position vector \hat{r} is zero. The situation is the same for an electron and a proton.

28.33. The field along the axis of a current loop of radius R as measured at a distance x from the center of the loop is

$$B = \frac{\mu_0 i}{2} \frac{R^2}{(x^2 + R^2)^{3/2}}.$$

The current of the loop must be

$$i = \frac{2(x^2 + R^2)^{3/2} B}{\mu_0 R^2} = \frac{2[(2.00 \cdot 10^6 \text{ m})^2 + (6.38 \cdot 10^6 \text{ m})^2]^{3/2}}{(4\pi \cdot 10^{-7} \text{ T m/A})(2.00 \cdot 10^6 \text{ m})^2} (6.00 \cdot 10^{-5} \text{ T}) = 7.14 \cdot 10^9 \text{ A}.$$

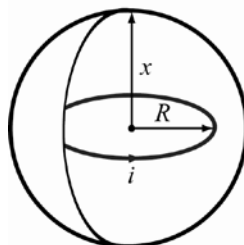

- 28.34. What does it mean to have an “average value of the magnetic field measured in the sides”? The answer is that the average value is: $\bar{B} = \oint \vec{B} \cdot d\vec{s} / \oint ds$. And $\oint ds$ is just the total length of the closed path around the loop, in this case $\oint ds = 4l$. For the integral above we can simply use Ampere’s Law and find (see equation 28.10):

$$\oint \vec{B} \cdot d\vec{s} = \mu_0 i_{\text{enc}}$$

We found above that $\bar{B} = \oint \vec{B} \cdot d\vec{s} / \oint ds = \oint \vec{B} \cdot d\vec{s} / 4l$. Inserting Ampere’s Law and solving for the enclosed current then yields:

$$\bar{B} = \mu_0 i_{\text{enc}} / 4l \Rightarrow i_{\text{enc}} = 4l\bar{B} / \mu_0$$

Numerically we find $i_{\text{enc}} = 4(0.0300 \text{ m})(3.00 \cdot 10^{-4} \text{ T}) / (4\pi \cdot 10^{-7}) = 28.64789 \text{ A}$, which we round to $i_{\text{enc}} = 28.6 \text{ A}$.

We can also see if our solution makes sense. We have calculated the magnetic field from a long straight wire as a function of the distance to the wire in equation 28.4 and found $B = \mu_0 i / 2\pi r_{\perp}$. With our value of the current computed above, we can calculate the value of the magnetic field at the corners of the loop (furthest from the wire) and middle of the sides (closest to the wire) and see that these two values of the magnetic field are below and above the average value of B that was given in the problem. For the middle of the sides we find ($r_{\perp} = l/2$): $B = 3.82 \cdot 10^{-4} \text{ T}$, and for the corners we find ($r_{\perp} = l/\sqrt{2}$): $B = 2.70 \cdot 10^{-4} \text{ T}$. This gives us confidence that we have the right solution.

- 28.35. **THINK:** A force due to the magnetic field generated by a current carrying wire acts on a moving particle. In order for the net force on the particle to be zero, a second force of equal magnitude and opposite direction must act on the particle. Such a force can be generated by another current carrying wire placed near the first wire. Assume the second wire is to be parallel to the first and has the same magnitude of current. The wire along the x -axis has a current of 2 A oriented along the x -axis. The particle has a charge of $q = -3 \mu\text{C}$ and travels parallel to the y -axis through point $(x, y, z) = (0, 2, 0)$.

SKETCH:

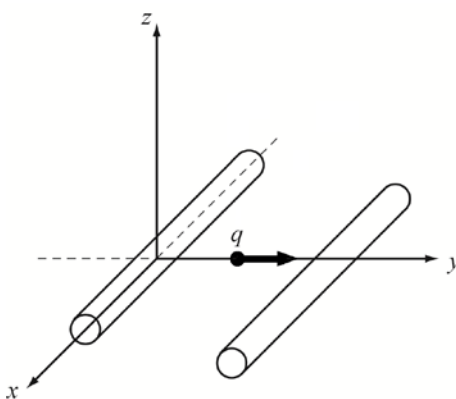

RESEARCH: The magnetic field produced by the current is given by the $B = \mu_0 i / (2\pi r)$. The force on the particle is given by the Lorentz force, $F = qv_0 B$.

SIMPLIFY: If the wires carry the same current then the new wire must be equidistant from the point that the particle passes through the xy -plane. Only then will the magnetic force on the particle due to each wire be equal. By the right hand rule, the currents will be in the same direction. This means that $r_1 = r_2$.

CALCULATE: The requirement $r_1 = r_2$ means that the second wire should be placed parallel to the first wire (parallel to the x -axis) so that it passes through the point $(x, y, z) = (0, 4, 0)$.

ROUND: Not necessary.

DOUBLE-CHECK: It is reasonable that two wires carrying the same current need to be equidistant from a point in order for the magnitude of the force to be the same.

- 28.36. THINK:** The current through the wire creates a magnetic field by the Biot-Savart Law. The straight part of the wire only creates a magnetic field at points perpendicular to it. Therefore this part of the wire can be ignored. The magnetic field at the center of the semicircle is created by the charge moving through the semicircle.

SKETCH:

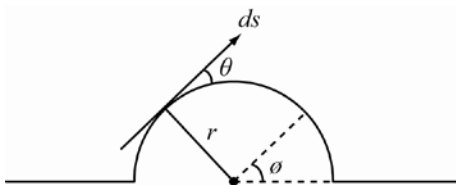

RESEARCH: The Biot-Savart Law can be employed in the form $dB = \frac{\mu_0 i \sin \theta}{4\pi r^2} ds$. Going around the semicircle, the angle ϕ can be related to the current element by $ds = r d\phi$.

SIMPLIFY: Performing the integration gives

$$B = \frac{\mu_0 i}{4\pi} \int_0^\pi \frac{\sin \theta}{r^2} R d\phi = \left[\frac{\mu_0 i \sin \theta}{4\pi r} \phi \right]_0^\pi = \frac{\mu_0 i \sin \theta \pi}{4\pi r} = \frac{\mu_0 i \sin \theta}{4r}.$$

The angle θ between the current and the radial vector \hat{r} is 90° for the loop, thus $B = \mu_0 i / (4r)$.

CALCULATE: $B = \frac{(4\pi \cdot 10^{-7} \text{ T m/A})(12.0 \text{ A})}{4(0.100 \text{ m})} = 3.76991 \cdot 10^{-5} \text{ T}$

ROUND: The values are given to three significant figures, thus the magnetic field produced by the wire is $B = 3.77 \cdot 10^{-5} \text{ T}$ and points into the page.

DOUBLE-CHECK: The magnetic field is very small, as would be expected from a real-world point of view.

- 28.37. THINK:** Each of the wires creates a magnetic field at the origin. The sum of these fields and the Earth's magnetic field will produce a force on the compass, causing it to align with the total field. The wires carry a current of $i_1 = i_2 = 25.0 \text{ A}$. The Earth's magnetic field is $\vec{B}_E = 2.6 \cdot 10^{-5} \hat{y} \text{ T}$.

SKETCH:

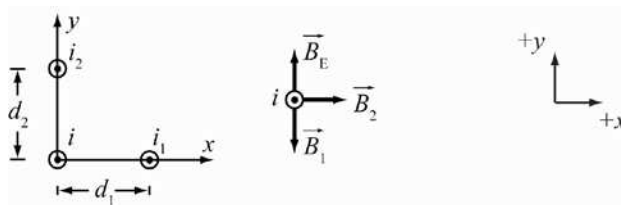

RESEARCH: The magnetic field produced by a wire is $B = \mu_0 i / (2\pi d)$.

SIMPLIFY: The magnetic field of wire 1 is $\vec{B}_1 = \mu_0 i_1 (-\hat{y}) / (2\pi d_1)$. Wire 2 produces a magnetic field of $\vec{B}_2 = \mu_0 i_2 \hat{x} / (2\pi d_2)$. The sum of the magnetic fields is $\vec{B}_{\text{net}} = \vec{B}_1 + \vec{B}_2 + \vec{B}_E = -\frac{\mu_0 i_1}{2\pi d_1} \hat{y} + \frac{\mu_0 i_2}{2\pi d_2} \hat{x} + \vec{B}_E$.

CALCULATE: $\vec{B}_{\text{net}} = -\frac{(4\pi \cdot 10^{-7} \text{ T m/A})(25.0 \text{ A})}{2\pi(0.15 \text{ m})} \hat{y} + \frac{(4\pi \cdot 10^{-7} \text{ T m/A})(25.0 \text{ A})}{2\pi(0.090 \text{ m})} \hat{x} + 2.6 \cdot 10^{-5} \text{ T} \hat{y}$
 $= 5.5555 \cdot 10^{-5} \text{ T} \hat{x} - 7.3333 \cdot 10^{-6} \text{ T} \hat{y}$

The direction of the field is $\theta = \tan^{-1}\left(\frac{-7.3333 \cdot 10^{-6} \text{ T}}{5.5555 \cdot 10^{-5} \text{ T}}\right) = -7.5196^\circ$.

ROUND: The angle is accurate to two significant figures. The compass points 7.5° below the x -axis.

DOUBLE-CHECK: This is a reasonable answer. The compass points towards the east if \hat{y} is north.

- 28.38. THINK:** The coil will levitate if the force from the magnetic field cancels the force of gravity. The coils have radii of $R = 20.0$ cm. The current of the bottom coil is i and travels in the clockwise direction. By the right hand rule the top coil has a current of the same magnitude, moving in a counter clockwise direction. The mass of the coils is $m = 0.0500$ kg. The distance between the coils is $d = 2.00$ mm.

SKETCH:

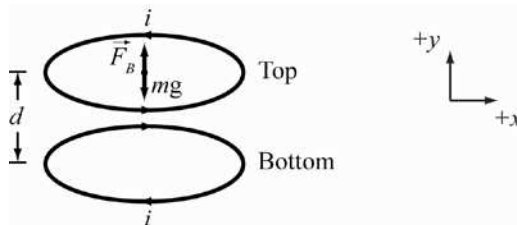

RESEARCH: The force of gravity is $F_g = mg$. The magnetic force on the top coil due to the bottom coil is $F_B = \mu_0 i_1 i_2 L / (2\pi d) = \mu_0 i_1 i_2 2\pi R / (2\pi d)$.

SIMPLIFY: Equating the two forces give $mg = \frac{\mu_0 i_1 i_2 2\pi R}{2\pi d} = \frac{\mu_0 i^2 R}{d}$. The amount of current is $i^2 = \frac{mgd}{\mu_0 R}$ or

$$i = \sqrt{\frac{mgd}{\mu_0 R}}$$

CALCULATE:
$$i = \sqrt{\frac{(0.0500 \text{ kg})(9.81 \text{ m/s}^2)(0.00200 \text{ m})}{(4\pi \cdot 10^{-7} \text{ T m/A})(0.200 \text{ m})}} = 62.476 \text{ A}$$

ROUND: Reporting to 3 significant figures, the current in the coils is 62.5 A and travel in opposite directions.

DOUBLE-CHECK: Dimensional analysis provides a check:

$$i = \sqrt{\frac{[\text{kg}][\text{m/s}^2][\text{m}]}{[\text{T}][\text{m/A}][\text{m}]}} = \sqrt{\frac{[\text{kg}][\text{m}][\text{m}][\text{A}]}{[\text{N}/(\text{A m})][\text{m}][\text{m}][\text{s}^2]}} = \sqrt{\frac{[\text{kg}][\text{m}][\text{m}][\text{A}][\text{A}][\text{s}^2][\text{m}]}{[\text{kg}][\text{m}][\text{m}][\text{m}][\text{s}^2]}} = [\text{A}].$$

- 28.39. THINK:** The current carrying wires along the x - and y -axes will each generate a magnetic field. The superposition of these fields generates a net field. The magnitude and direction of this net field at a point on the z -axis is to be determined.

SKETCH:

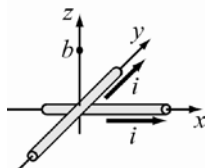

RESEARCH: Both currents produce a magnetic field with magnitude $B = \mu_0 i / (2\pi r)$. The magnetic field produced by the wire along the x -axis gives $\vec{B}_1 = \mu_0 i (-\hat{y}) / (2\pi b)$. The wire along the y -axis creates a magnetic field of $\vec{B}_2 = \mu_0 i \hat{x} / (2\pi b)$.

SIMPLIFY: The total magnetic field is then $\vec{B}_{\text{net}} = \vec{B}_1 + \vec{B}_2 = \frac{\mu_0 i}{2\pi b} \hat{x} - \frac{\mu_0 i}{2\pi b} \hat{y}$. The magnitude of the field is $B = \frac{\mu_0 i}{2\pi b} \sqrt{1^2 + (-1)^2} = \frac{\sqrt{2}\mu_0 i}{2\pi b} = \frac{\mu_0 i}{\sqrt{2}\pi b}$. The direction of the field is $\theta = \tan^{-1}\left(\frac{-\mu_0 i / \sqrt{2}\pi b}{\mu_0 i / \sqrt{2}\pi b}\right)$ in the x - y plane at a height of b .

CALCULATE: $\tan^{-1}(-1) = -45^\circ$ in the x - y plane at point b .

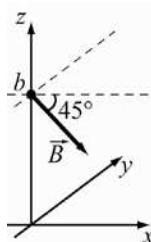

ROUND: Not applicable.

DOUBLE CHECK: Both the right hand rule and the symmetry of the problem indicates that the net field should be in the fourth quadrant.

- 28.40. THINK:** The loop creates a magnetic field at its center by the Biot-Savart Law. The loop has side length $l = 0.100$ m and carries a current of $i = 0.300$ A.

SKETCH:

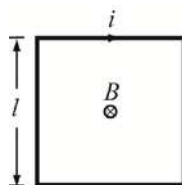

RESEARCH: The Biot-Savart Law states $dB = \frac{\mu_0}{4\pi} \cdot \frac{i \sin\theta ds}{r^2}$. The angle θ is found by using the equations:

$\sin\theta = d/r$, $r = \sqrt{s^2 + d^2}$, and $d = l/2$.

SIMPLIFY: The field due to one side of the loop is $dB = \frac{\mu_0 i}{4\pi} \cdot \frac{d}{r^2} ds = \frac{\mu_0 i d}{4\pi} \frac{ds}{(s^2 + d^2)^{3/2}}$. Since there are

four sides, the total loop is four times this value. The total magnetic field is then

$$\begin{aligned} B &= \int dB = 4 \int_{-d}^d \frac{\mu_0 i d}{4\pi} \cdot \frac{ds}{(s^2 + d^2)^{3/2}} = 4 \int_0^d \frac{\mu_0 i d}{4\pi} \frac{2ds}{(s^2 + d^2)^{3/2}} \\ &= \frac{2\mu_0 i d}{\pi} \left[\frac{s}{d^2 \sqrt{s^2 + d^2}} \right]_0^d = \frac{2\mu_0 i}{\pi d} \left(\frac{d}{\sqrt{2d^2}} - \frac{0}{\sqrt{d^2}} \right) = \frac{2\mu_0 i}{\sqrt{2}\pi d} = \frac{\sqrt{8}\mu_0 i}{\pi l} \end{aligned}$$

CALCULATE: $B = \frac{\sqrt{8}(4\pi \cdot 10^{-7} \text{ T m/A})(0.300 \text{ A})}{\pi(0.100 \text{ m})} = 3.394 \cdot 10^{-6} \text{ T}$

ROUND: To three significant figures, the magnetic field at the center of the loop is $B = 3.39 \cdot 10^{-6} \text{ T}$.

DOUBLE-CHECK: The current is small, so the magnetic field it generates is expected to be small. This is a reasonable value.

- 28.41. THINK:** In order for wire 1 to levitate, the forces on it must cancel. Both wire 2 and 3 will create magnetic fields that will interact with wire 1. Both wires create forces with horizontal and vertical components. The horizontal components will add destructively. The vertical components however will add constructively.

Therefore, only the vertical components need be calculated. Wires 2 and 3 each carry a current of $i = 600$. A. All three wires have a linear mass density of $\lambda = 100$. g/m. The wires are arranged as shown in the figure.

SKETCH:

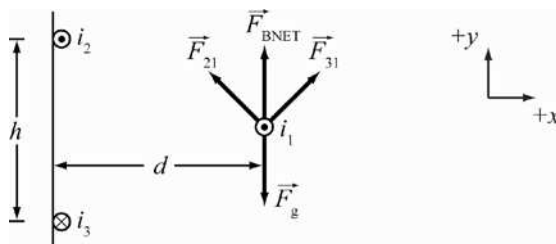

RESEARCH: The force of gravity on the wire is $F_g = mg$. The force between two wires carrying current is

$$F_{21} = \mu_0 i_1 i_2 L / (2\pi d).$$

SIMPLIFY: The vertical component of the magnetic force for one wire is $F_{31} = \frac{\mu_0 i_3 i_1 L}{2\pi(h/2)} = \frac{\mu_0 i_3 i_1 L}{\pi h}$. The

total force due to the wires is then $F_B = 2F_{31} = \frac{2\mu_0 i_3 i_1 L}{\pi h}$. Equating this to the force of gravity gives:

$$mg = \lambda L g = \frac{2\mu_0 i_3 i_1 L}{\pi h}. \text{ Solving for the current } i_1 \text{ gives: } i_1 = \frac{\pi h \lambda g}{2\mu_0 i_3}.$$

$$\text{CALCULATE: } i_1 = \frac{\pi(0.100 \text{ m})(100 \cdot 10^{-3} \text{ kg/m})(9.81 \text{ m/s}^2)}{2(4\pi \cdot 10^{-7} \text{ T m/A})(600. \text{ A})} = 204.375 \text{ A}$$

ROUND: The current of wire 1 required to levitate is $i_1 = 204$ A.

DOUBLE-CHECK: The current in wire 1 is on the same order of magnitude as the other currents. This is a reasonable answer.

- 28.42. **THINK:** The net field is a superposition of the fields created by the top wire, the bottom wire and the loop. The wires are 2.00 cm apart and carry a current of $i = 3.00$ A. The radius of the loop is $r = 1.00$ cm.

SKETCH:

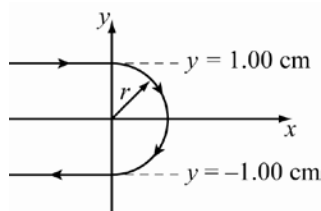

RESEARCH: The magnetic field produced by an infinite wire is $B = \mu_0 i / (2\pi r)$. A semi-infinite wire is half this value, $B = \mu_0 i / (4\pi r)$. A full loop produces a magnetic field of $B = \mu_0 i / (2r)$. The half loop produces half of this, $B = \mu_0 i / (4r)$.

SIMPLIFY: By the right hand rule, the magnetic field points into the page. The magnetic field is the sum of all the fields.

$$B_{\text{net}} = B_{\text{top}} + B_{\text{bottom}} + B_{\text{loop}} = \frac{\mu_0 i}{4\pi r} + \frac{\mu_0 i}{4\pi r} + \frac{\mu_0 i}{4r} = \frac{\mu_0 i}{4r} \left(\frac{2}{\pi} + 1 \right)$$

CALCULATE: $B_{\text{net}} = \frac{(4\pi \cdot 10^{-7} \text{ T m/A})(3.00 \text{ A})}{4(0.0100 \text{ m})} \left(\frac{2}{\pi} + 1 \right) = 1.54 \cdot 10^{-4} \text{ T}$. It is directed in the negative z direction.

ROUND: To 3 significant figures, the magnetic field at the origin is $-1.54 \cdot 10^{-4} \text{ T}\hat{z}$.

DOUBLE-CHECK: The field due to a single infinite wire similar to the wires in the problem would be $B = (4\pi \cdot 10^{-7} \text{ T m/A})(3.00 \text{ A}) / (2\pi(0.0100 \text{ m})) = 6.00 \cdot 10^{-5} \text{ T}$, which is similar to the result. Therefore, the result is reasonable.

- 28.43. THINK:** The wire creates a magnetic field that produces a Lorentz force on the moving charged particle. The question asked for the force if the particle travels in various directions. The velocity is 3000 m/s in various directions.

SKETCH:

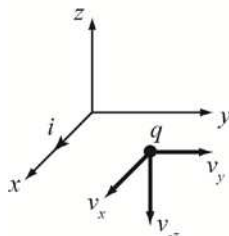

RESEARCH: The magnetic field produced by an infinite wire is $B = \mu_0 i / (2\pi d)$. By the right hand rule the field points in the positive z -direction. The force produced by the magnetic field is $\vec{F} = q\vec{v} \times \vec{B}$.

SIMPLIFY: The force is given by $\vec{F} = q\vec{v} \times \vec{B} = \frac{q\mu_0 i}{2\pi d} \vec{v} \times \hat{z} = \frac{q\mu_0 i}{2\pi d} (|\vec{v}| \cdot \hat{n} \times \hat{z})$ where \hat{n} is the direction of the particle.

CALCULATE: $\vec{F} = \frac{(9.00 \text{ C})(4\pi \cdot 10^{-7} \text{ T m/A})(7.00 \text{ A})}{2\pi(2.00 \text{ m})} (3000. \text{ m/s} \cdot \hat{n} \times \hat{z}) = 1.89 \cdot 10^{-2} \text{ N}(\hat{n} \times \hat{z})$

Note that $\hat{x} \times \hat{z} = -\hat{y}$, $\hat{y} \times \hat{z} = \hat{x}$, and $-\hat{z} \times \hat{z} = 0$.

ROUND: The force should be reported to 3 significant figures.

- (a) The force is $\vec{F} = -1.89 \cdot 10^{-2} \text{ N } \hat{y}$ if the particle travels in the positive x -direction.
 (b) The force is $\vec{F} = 1.89 \cdot 10^{-2} \text{ N } \hat{x}$ if the particle travels in the positive y -direction.
 (c) The force is $F = 0$ if the particle travels in the negative z -direction.

DOUBLE-CHECK: The right hand rule confirms the directions of the forces for each direction of motion of the particle.

- 28.44. THINK:** The wire produces a magnetic field that creates a force on the loop. The wire has current of $i_w = 10.0 \text{ A}$ and is $d = 0.500 \text{ m}$ away from the bottom wire of the loop. The loop carries a current of $i_1 = 2.00 \text{ A}$ and has sides of length $a = 1.00 \text{ m}$.

SKETCH:

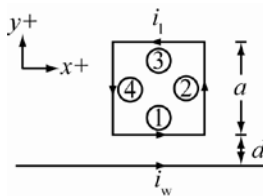

RESEARCH: The force on two wires carrying a current is $F = \mu_0 i_1 i_2 L / (2\pi d)$. The torque is given by $\vec{\tau} = \vec{r} \times \vec{F}$.

SIMPLIFY: The forces on part ② and ④ cancel each other. The force on ① is $F_1 = \mu_0 i_w i_1 a / (2\pi d)$ and points towards the long wire. The force on ③ is $F_3 = \mu_0 i_w i_1 a / [2\pi(d + a)]$ and points away from the long

wire. The total force is then $F_{\text{net}} = \vec{F}_1 + \vec{F}_3 = \frac{\mu_0 i_w i_l a}{2\pi} \left(\frac{1}{d} - \frac{1}{d+a} \right)$ and points towards the long wire. Because the force and the length between the axis of rotation are parallel there is no torque on the loop.

CALCULATE:

$$F_{\text{net}} = \frac{(4\pi \cdot 10^{-7} \text{ Tm/A})(10.0 \text{ A})(2.00 \text{ A})(1.00 \text{ m})}{2\pi} \left(\frac{1}{0.500 \text{ m}} - \frac{1}{1.50 \text{ m}} \right) = -5.33333 \cdot 10^{-6} \hat{y} \text{ N}$$

ROUND: The force is reported to three significant figures. (a) The net force between the loop and the wire is $F = -5.33 \cdot 10^{-6} \hat{y} \text{ N}$. (b) There is no net torque on the loop.

DOUBLE-CHECK: The force between the long wire and the lower arm of the loop is attractive, because the currents are in the same direction. The currents of the long wire and the upper arm of the loop are in opposite directions, therefore the force is repulsive. Since the lower arm is closer to the long wire, the attractive force dominates, and the net force is in the negative y direction, as calculated.

28.45. The magnetic field at the center of the box is the sum of the fields produced by the coils. A coil produces a

$$\text{magnetic field of } B = \frac{\mu_0 NiR^2}{2(x^2 + R^2)^{3/2}} \hat{n}.$$

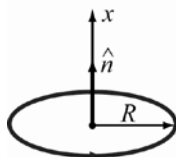

The magnetic field produced by the coil on the $x-z$ plane is

$$B_{xz} = \frac{(4\pi \cdot 10^{-7} \text{ T m/A})(30.0)(5.00 \text{ A})(0.500 \text{ m})^2}{2[(0.500 \text{ m})^2 + (0.500 \text{ m})^2]^{3/2}} (+\hat{y}) = 6.66 \cdot 10^{-5} \text{ T} \hat{y}$$

The magnetic field produced by the other coil has the same magnitude but points in the negative x -direction. Therefore $B_{\text{tot}} = 6.66 \cdot 10^{-5} \text{ T} [-\hat{x} + \hat{y}]$. The magnitude of the field is $\sqrt{2} \cdot 6.66 \cdot 10^{-5} \text{ T}$, or $9.42 \cdot 10^{-5} \text{ T}$. The direction of the field is at an angle of 45° from the negative x -direction towards the positive y -axis.

28.46.

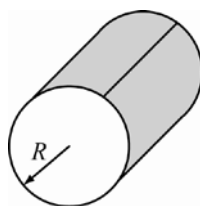

The current within a loop of radius $\rho \leq R$ is given by

$$i = \int J(r) dA = 2\pi \int_0^r J(r') r' dr' = 2\pi J_0 \int_0^r \frac{r'}{R} r' dr' = \frac{2\pi J_0}{R} \int_0^r r'^2 dr' = \frac{2\pi J_0}{R} \frac{r'^3}{3} \Big|_0^r = \frac{2\pi J_0 r^3}{3R}.$$

The magnetic field is given by Ampere's Law

$$\oint \vec{B} \cdot d\vec{s} = B(2\pi r) = \mu_0 i_{\text{enc}} \Rightarrow B = \frac{\mu_0 i_{\text{enc}}}{2\pi r}.$$

The magnetic field in the region $r < R$ is $B = \frac{\mu_0}{2\pi r} \left(\frac{2\pi J_0 r^3}{3R} \right) = \frac{\mu_0 J_0 r^2}{3R}$. The magnetic field in the region

$$r > R \text{ is } B = \frac{\mu_0}{2\pi r} \left(\frac{2\pi J_0 R^3}{3R} \right) = \frac{\mu_0 J_0 R^2}{3r}.$$

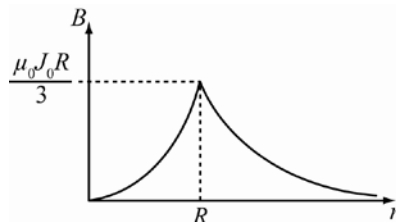

- 28.47. Using Ampere's Law, the magnetic field at various points can be determined. $\oint \vec{B} \cdot d\vec{s} = \mu_0 i_{\text{enclosed}}$. For the cylinder, assuming the current is distributed evenly, $B2\pi r = \mu_0 i_{\text{enc}}$ or $B = \mu_0 i_{\text{enc}} / (2\pi r)$. The field at $r = r_a = 0$ is zero since it does not enclose any current $B_a = 0$. The field at $r = r_b < R$ is

$$B_b = \frac{\mu_0 i_{\text{enc}}}{2\pi r_b} = \frac{\mu_0}{2\pi r_b} \left(i_{\text{tot}} \frac{\pi r_b^2}{\pi R^2} \right) = \frac{\mu_0 i r_b}{2\pi R^2} = \frac{(4\pi \cdot 10^{-7} \text{ T m/A})(1.35 \text{ A})(0.0400 \text{ m})}{2\pi(0.100 \text{ m})^2} = 1.08 \cdot 10^{-6} \text{ T.}$$

Note that i is equal to the fraction of total area of the conductor's cross section and the total current. The field at

$$r_c = R \text{ is } B_c = \frac{\mu_0 i_{\text{enc}}}{2\pi r_c} = \frac{\mu_0 i_{\text{tot}}}{2\pi R} = \frac{(4\pi \cdot 10^{-7} \text{ T m/A})(1.35 \text{ A})}{2\pi(0.100 \text{ m})} = 2.70 \cdot 10^{-6} \text{ T.}$$

The field at $r_d > R$ is

$$B_d = \frac{\mu_0 i_{\text{enc}}}{2\pi r_d} = \frac{(4\pi \cdot 10^{-7} \text{ T m/A})(1.35 \text{ A})}{2\pi(0.160 \text{ m})} = 1.69 \cdot 10^{-6} \text{ T.}$$

By inspection it can be seen that the magnetic field at r_b , r_c and r_d the magnetic field will point to the right.

- 28.48. **THINK:** The magnetic field is the sum of the field produced by the wire core B_c and the sheath B_s . The wire has a radius of $a = 1.00$ mm. The sheath has an inner radius of $b = 1.50$ mm and outer radius of $c = 2.00$ mm. The current of the outer sheath opposes the current in the core.

SKETCH:

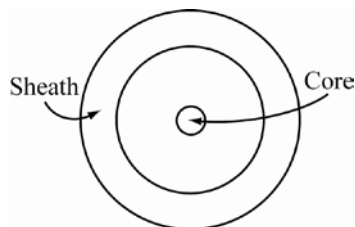

RESEARCH: The current density of the core is $J_c = i / (\pi a^2)$ and the current density of the sheath is $J_s = -i / [\pi(c^2 - b^2)]$. The enclosed current is calculated by $i_{\text{enclosed}} = \int J dA$. The magnetic field is derived using Ampere's Law: $\oint \vec{B} \cdot d\vec{s} = \mu_0 i_{\text{enclosed}}$.

SIMPLIFY: When the radius is within the core, $r \leq a$, the magnetic field is

$$\begin{aligned} \oint \vec{B} \cdot d\vec{s} &= B_{r \leq a} 2\pi r = \mu_0 i_{\text{enc}} = \mu_0 \int J dA = \mu_0 \frac{i}{\pi a^2} \int_0^r \int_0^{2\pi} r d\theta dr \\ &= \frac{\mu_0 i}{\pi a^2} \frac{2\pi r^2}{2} = \mu_0 i \frac{r^2}{a^2} \end{aligned}$$

or $B_{r \leq a} = \frac{\mu_0 i}{2\pi r} \frac{r^2}{a^2} = \frac{\mu_0 i r}{2\pi a^2}$. If the radius is between the core and the sheath, $a < r < b$,

$\oint \vec{B} \cdot d\vec{s} = B_{a < r \leq b} 2\pi r = \mu_0 i$ or $B_{a < r \leq b} = \mu_0 i / (2\pi r)$. Within the sheath, $b < r < c$, the magnetic field is

$$\oint \vec{B} \cdot d\vec{s} = B_{b < r < c} 2\pi r = \mu_0 i_{\text{enc}} = \mu_0 \left(i + \int_b^r \int_0^{2\pi} \frac{-i}{\pi(c^2 - b^2)} r d\theta dr \right) = \mu_0 \left(i - \frac{i}{(c^2 - b^2)} \frac{2\pi r^2}{\pi 2} \Big|_b^r \right) = \mu_0 i \left[1 - \frac{r^2 - b^2}{c^2 - b^2} \right]$$

$$B_{b < r < c} = \frac{\mu_0 i}{2\pi r} \left[1 - \frac{r^2 - b^2}{c^2 - b^2} \right]$$

If the radius is outside of the cable, $r \geq c$, then the magnetic field is $\oint B \cdot ds = B_{r \geq c} 2\pi r = \mu_0 i_{\text{enc}} = \mu_0 (i - i) = 0$ or $B_{r \geq c} = 0$. In summary the magnetic fields of various regions are

$$B_{r \leq a} = \frac{\mu_0 i r}{2\pi a^2}, B_{a < r \leq b} = \frac{\mu_0 i}{2\pi r}, B_{b < r < c} = \frac{\mu_0 i}{2\pi r} \left[1 - \frac{r^2 - b^2}{c^2 - b^2} \right], B_{r \geq c} = 0.$$

CALCULATE: In order to graph the behavior of the magnetic field as a function of the radius, set the magnetic field in units of $\frac{\mu_0 i}{2\pi a}$.

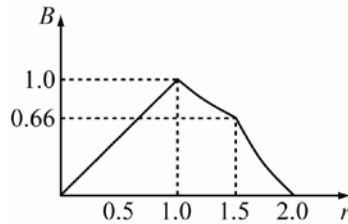

ROUND: There is no need to round.

DOUBLE-CHECK: Note that the magnetic field outside of the coaxial cable is zero. These cables are used when equipment that is sensitive to magnetic fields needs current.

- 28.49. **THINK:** To find the magnetic field above the center of the surface of a current carrying sheet, use Ampere's Law. The path taken should be far from the edges and should be rectangular as shown in the diagram. The current density of the sheet is $J = 1.5 \text{ A/cm}$.

SKETCH:

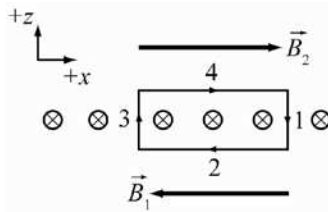

RESEARCH: The direction of the magnetic field is found using the right hand rule to be $+x$ above the surface of the conductor. Ampere's Law states $\oint \vec{B} \cdot d\vec{s} = B 2\pi r = \mu_0 i_{\text{enclosed}}$.

SIMPLIFY: Note that sections 1 and 3 are perpendicular the field. $B \cdot ds = 0$ for these two sections. If the path of 4 and 2 has a length of L , then by Ampere's Law, $\oint B \cdot ds = B_1 L + B_2 L = \mu_0 i_{\text{enclosed}} = \mu_0 J L$. By symmetry $B_1 = B_2$. Thus, $2B_1 = \mu_0 J$ or $B_1 = \mu_0 J / 2$.

CALCULATE: $B_1 = \frac{(4\pi \cdot 10^{-7} \text{ T m/A})(1.5 \text{ A/cm})(100 \text{ cm/m})}{2} = 9.42478 \cdot 10^{-5} \text{ T}$

ROUND: The magnetic field is accurate to two significant figures. The magnetic field near the surface of the conductor is $B_1 = 9.4 \cdot 10^{-5} \text{ T}$.

DOUBLE-CHECK: The form for the magnetic field is similar to that of a solenoid. It is divided by a factor of 2, which makes sense when considering the setup of a solenoid. The form of the equation is similar to that of question 28.12. This makes sense because the magnetic field inside a solenoid is generated by a current carrying wire on both sides of the Amperian loop, whereas the field generated by the flat conducting surface originates on one side of the Amperian loop only. In effect, the flat conductor can be seen as similar to half a solenoid, flattened out. See figure 28.21 in the text for a visual.

28.50. The magnetic field in a solenoid is given by the equation:

$$B = \mu_0 ni = (4\pi \cdot 10^{-7} \text{ T m/A}) \left(\frac{1000}{0.400 \text{ m}} \right) (2.00 \text{ A}) = 6.28 \cdot 10^{-3} \text{ T}.$$

28.51. The magnetic field in a solenoid is given by $B = \mu_0 in$. Let the magnetic field of solenoid B be $B_B = \mu_0 in$. The magnetic field of solenoid A is $B_A = \mu_0 i(4 \text{ N}) / (3 \text{ L}) = (4/3) \mu_0 in = (4/3) B_B$. The ratio of solenoid A magnetic field to that of solenoid B is 4:3.

28.52. The magnetic field at a point $r = 1.00 \text{ cm}$ from the axis of the solenoid will be the sum of the field due to the solenoid and the field produced by the wire. The solenoid has a magnetic field of $B_s = \mu_0 i_s n$ along the axis of the solenoid.

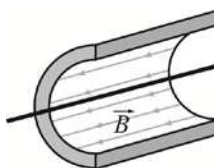

The wire produces a field which is perpendicular to the radial vector of $B_w = \mu_0 i_w / (2\pi r)$. The magnitude of the field is then

$$B_{\text{tot}} = \sqrt{B_s^2 + B_w^2} = \mu_0 \sqrt{(i_s n)^2 + (i_w / 2\pi r)^2}$$

$$B_{\text{tot}} = (4\pi \cdot 10^{-7} \text{ T m/A}) \sqrt{\left((0.250 \text{ A})(1000 \text{ m}^{-1}) \right)^2 + \left(\frac{(10.0 \text{ A})}{2\pi(0.0100 \text{ m})} \right)^2} = 3.72 \cdot 10^{-4} \text{ T}.$$

28.53. (a) The magnetic field produced by the wire is

$$B = \mu_0 i / (2\pi r) = (4\pi \cdot 10^{-7} \text{ T m/A}) (2.5 \text{ A}) / (2\pi(0.039 \text{ m})) = 1.3 \cdot 10^{-5} \text{ T}.$$

(b) The magnetic field of the solenoid is

$$B = \mu_0 in = (4\pi \cdot 10^{-7} \text{ T m/A}) (2.5 \text{ A}) \left(\frac{32}{0.01 \text{ m}} \right) = 0.010 \text{ T} = 1.0 \cdot 10^{-2} \text{ T}.$$

This field is much larger for the solenoid than the wire.

28.54. The magnetic field of a loop is $B = \frac{\mu_0 i}{2} \frac{R^2}{(x^2 + R^2)^{3/2}}$.

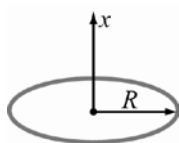

Therefore a coil of N loops produces a field of $B = \frac{\mu_0 i N}{2} \frac{R^2}{(x^2 + R^2)^{3/2}}$. Let $x = R/2$ gives

$$B = \frac{\mu_0 i N}{2} \frac{R^2}{(x^2 + R^2)^{3/2}} = \frac{\mu_0 i N}{2R^3} \frac{R^2}{(5/4)^{3/2}} = \left(\frac{4}{5}\right)^{3/2} \frac{\mu_0 i N}{2R}. \text{ The field at the center of the coils is then}$$

$$B_{\text{tot}} = 2B = \left(\frac{4}{5}\right)^{3/2} \frac{\mu_0 i N}{R} = \left(\frac{4}{5}\right)^{3/2} \frac{(4\pi \cdot 10^{-7} \text{ T m/A})(0.123 \text{ A})(15)}{(0.750 \text{ m})} = 2.21 \cdot 10^{-6} \text{ T}.$$

- 28.55. THINK:** If the perpendicular momentum of a particle is not large enough, its radius of motion will not be large enough to enter the detector. The minimum momentum perpendicular to the axis of the solenoid is determined by a condition such that the centripetal force is equal to the force due to the magnetic field.

SKETCH:

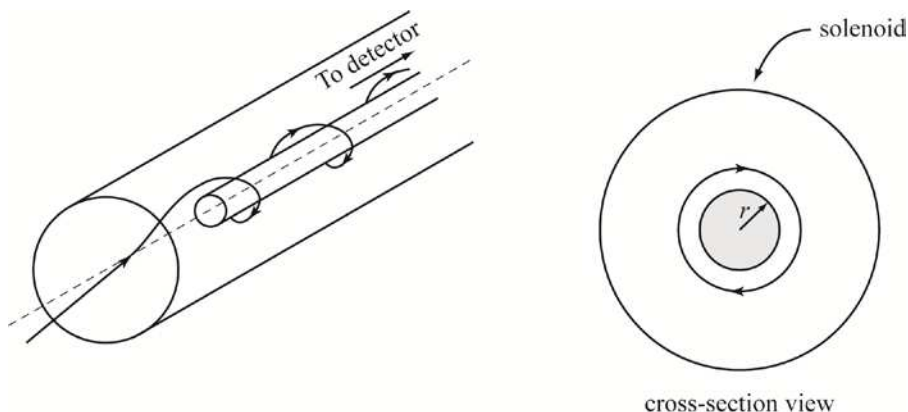

RESEARCH: Since the particle originates from the axis of the detector, the minimum radius of the circular motion of the particle must be equal to the radius of the detector as shown above. The magnetic force on the particle is $F = qvB$. Centripetal acceleration is $a_c = v^2 / r$. The magnetic field due to the solenoid is $B = \mu_0 i n$.

SIMPLIFY: Using Newton's Second Law, the momentum is $qvB = mv^2 / r \Rightarrow mv = p = qrB$. Therefore, the minimum momentum is $p = \mu_0 q r i n$.

CALCULATE: Substituting the numerical values yields.

$$p = (4\pi \cdot 10^{-7} \text{ T m/A})(1.602 \cdot 10^{-19} \text{ C})(0.80 \text{ m})(22 \text{ A})(550 \cdot 10^2 \text{ m}^{-1}) = 1.949 \cdot 10^{-19} \text{ kg m/s}$$

ROUND: Rounding the result to two significant figures gives $p = 1.9 \cdot 10^{-19} \text{ kg m/s}$.

DOUBLE-CHECK: This is a reasonable value.

- 28.56.** The magnetic potential energy of a magnetic dipole in an external magnetic field is given by $U = -\vec{\mu} \cdot \vec{B}$. Therefore, the magnitude of the difference in energy for an electron "spin up" and "spin down" is $\Delta U = |U_{\text{up}} - U_{\text{down}}| = 2\mu B$. This means the magnitude of the magnetic field is $B = \Delta U / 2\mu$.

$$\text{Putting in the numerical values gives } B = \frac{9.460 \cdot 10^{-25} \text{ J}}{2(9.285 \cdot 10^{-24} \text{ A m}^2)} = 0.05094 \text{ T}.$$

- 28.57.** The energy of a dipole in a magnetic field is $U = -\vec{\mu} \cdot \vec{B}$. The dipole has its lowest energy $U_{\text{min}} = -\vec{\mu} \cdot \vec{B} = -\mu B$, and its highest energy $U_{\text{max}} = \mu B$. The energy required to rotate the dipole from its lowest energy to its highest energy is $\Delta U = 2\mu B$. This means that the thermal energy needed is ΔU which corresponds to a temperature $T = \Delta U / k_B = 2\mu B / k_B$.

Substituting the numerical values of the dipole moment of hydrogen atom and $B = 0.15 \text{ T}$ yields

$$T = \frac{2(9.27 \cdot 10^{-24} \text{ J/T})(0.15 \text{ T})}{(1.38 \cdot 10^{-23} \text{ J/K})} = 0.20 \text{ K}.$$

28.58.

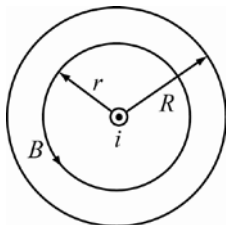

The magnetic permeability of aluminum is $\mu = (1 + \chi_{\text{Al}})\mu_0$. Applying Ampere's Law around an Amperian loop of radius r gives

$$\oint \vec{B} \cdot d\vec{s} = B \oint ds = B(2\pi r) = \mu i_{\text{enc}}.$$

The current enclosed by the Amperian loop is $i_{\text{enc}} = i \frac{\pi r^2}{\pi R^2}$. Therefore, the magnetic field inside a wire is

given by $B = \frac{\mu i r}{2\pi R^2}$. This means the maximum magnetic field is located at the surface of the wire where

the magnitude is $B = \frac{\mu i}{2\pi R}$. Thus, the maximum current is

$$i_{\text{max}} = \frac{2\pi R B_{\text{max}}}{(1 + \chi_{\text{Al}})\mu_0} = \frac{2\pi(1.0 \cdot 10^{-3} \text{ m})(0.0105 \text{ T})}{(1 + (2.2 \cdot 10^{-5}))(4\pi \cdot 10^{-7} \text{ T m/A})} = 52 \text{ A}.$$

28.59. The magnitude of the magnetic field inside a solenoid is given by $B = \mu i n = \kappa_m \mu_0 i (N/L)$. Thus the relative magnetic permeability κ_m is given by the equation:

$$\kappa_m = \frac{BL}{\mu_0 i N} = \frac{(2.96 \text{ T}) \cdot (3.50 \cdot 10^{-2} \text{ m})}{(4\pi \cdot 10^{-7} \text{ T m/A}) \cdot (3.00 \text{ A}) \cdot (500.)} = 54.96 \approx 55.0.$$

28.60.

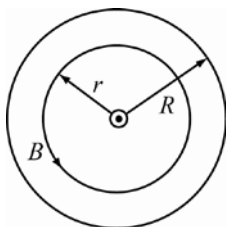

The magnetic permeability of tungsten is $\mu = (1 + \chi_{\text{W}})\mu_0$. Applying Ampere's Law around an Amperian loop of radius r gives

$$\oint \vec{B} \cdot d\vec{s} = B \oint ds = B(2\pi r) = \mu i_{\text{enc}}.$$

The current enclosed by the Amperian loop is $i_{\text{enc}} = i \frac{\pi r^2}{\pi R^2}$. Therefore, the magnetic field is

$$B = \left(\frac{(1 + \chi_{\text{W}})\mu_0 i}{2\pi R^2} \right) r = \frac{(1 + 6.8 \cdot 10^{-5})(4\pi \cdot 10^{-7} \text{ T m/A})(3.5 \text{ A})(0.60 \cdot 10^{-3} \text{ m})}{2\pi(1.2 \cdot 10^{-3} \text{ m})^2} = 2.9 \cdot 10^{-3} \text{ T}.$$

- 28.61. **THINK:** To determine the magnetic moment, the effective current of the system is needed. This implies the speed of the ball is required.

SKETCH:

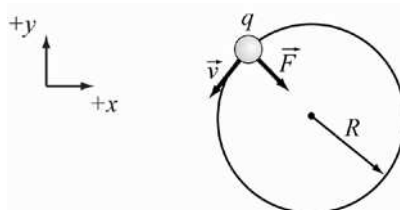

RESEARCH: The ball travels in a circular orbit and it travels a distance of $2\pi R$ in time T , where T is the time for one revolution. The effective current is given by $i = q/T$. Since $T = 2\pi R/v$, this becomes $i = qv/(2\pi R)$. The effective magnetic moment is $\mu = iA = qv\pi R^2/(2\pi R) = qvR/2$. From the centripetal force, it is found that the speed is $mv^2/R = F \Rightarrow v = \sqrt{FR/m}$.

SIMPLIFY: Combining the above results yields $\mu = \frac{1}{2}q\sqrt{\frac{FR}{m}}R$.

CALCULATE: Putting in the numerical values gives

$$\mu = \frac{1}{2}(2.00 \cdot 10^{-6} \text{ C})\sqrt{\frac{(25.0 \text{ N})(1.00 \text{ m})}{0.200 \text{ kg}}}(1.00 \text{ m}) = 1.118 \cdot 10^{-5} \text{ A m}^2.$$

ROUND: Keeping 3 significant figures gives $\mu = 1.12 \cdot 10^{-5} \text{ A m}^2$.

DOUBLE-CHECK: This magnetic moment is appropriately small for a small charge moving at a low velocity.

- 28.62. **THINK:** The magnetic field due to a proton is modeled as a dipole field. Using the value of the magnetic field, the potential energy of an electron spin in the magnetic field is $U = -\vec{\mu} \cdot \vec{B}$.

SKETCH:

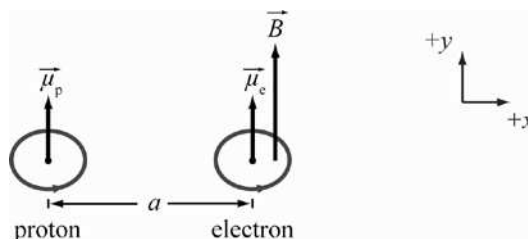

RESEARCH: The electron field due to an electric dipole is given by $\vec{E} = \vec{P}/(2\pi\epsilon_0 R^3)$. The corresponding magnetic field is obtained by replacing $1/(4\pi\epsilon_0)$ with $\mu_0/(4\pi)$ and \vec{P} with $\vec{\mu}$. Thus, $\vec{B} = \mu_0 \vec{\mu}/(2\pi R^3)$.

SIMPLIFY: The energy difference between two electron-spin configurations is

$$\begin{aligned} \Delta U &= U_{\text{anti}} - U_{\text{parallel}} \\ &= -(-\vec{\mu}_e) \cdot \vec{B} - (-\vec{\mu}_e \cdot \vec{B}) \\ &= 2\vec{\mu}_e \cdot \vec{B} = 2\vec{\mu}_e \cdot \frac{\mu_0 \vec{\mu}_p}{2\pi a_0^3} \\ &= \frac{\mu_0 \mu_e \mu_p}{\pi a_0^3} \end{aligned}$$

CALCULATE: Inserting all the numerical values yields

$$\Delta U = \frac{(4\pi \cdot 10^{-7} \text{ T m/A})(9.27 \cdot 10^{-24} \text{ J/T})(1.41 \cdot 10^{-26} \text{ J/T})}{\pi(5.292 \cdot 10^{-11} \text{ m})^3} = 3.528 \cdot 10^{-25} \text{ J} = 2.204 \cdot 10^{-6} \text{ eV}.$$

ROUND: Rounding the result to three significant digits produces $\Delta U = 2.20 \cdot 10^{-6} \text{ eV}$.

DOUBLE-CHECK: This is reasonable. A small difference in potential is expected for these small particles.

- 28.63. THINK:** The classical angular momentum of rotating object is related to its moment of inertia. To get the magnetic dipole of a uniformly charged sphere, the spherical volume is divided into small elements. Each element produces a current and a magnetic dipole moment. The dipole moment of all elements is then added to get the net dipole moment.

SKETCH:

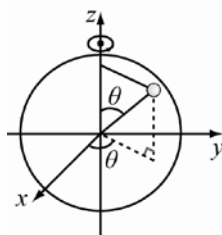

RESEARCH:

(a) The classical angular momentum of the sphere is given by $L = I\omega = (2/5)mR^2\omega$.

(b) The current produced by a small volume element dV is $i = \rho dV\omega / (2\pi)$. Thus the magnetic dipole moment of this element is $d\mu = \frac{\rho\omega dV}{2\pi} \pi(r \sin \theta)^2$. Integrating all the elements gives

$$\mu = \int_0^{2\pi} \int_0^\pi \int_0^R \frac{\rho\omega r^2}{2} (\sin^2 \theta) (r^2 \sin \theta) dr d\theta d\phi.$$

(c) The gyromagnetic ratio is simply the ratio of the results from parts (a) and (b): $\gamma_e = \mu / L$.

SIMPLIFY:

$$\begin{aligned} \text{(b)} \quad \mu &= \frac{\rho\omega}{2} \cdot 2\pi \int_0^\pi \int_0^R r^4 \sin^3 \theta dr d\theta \\ &= \rho\pi\omega \int_0^\pi \sin^3 \theta d\theta \cdot \int_0^R r^4 dr \\ &= \rho\pi\omega \left[\int_{\cos 0}^{\cos \pi} -(1 - \cos^2 \theta) d \cos \theta \right] \frac{R^5}{5} = \rho\pi\omega \left[-x + \frac{x^3}{3} \right]_1^{-1} \frac{R^5}{5} = \rho\pi\omega \left(\frac{4}{3} \right) \frac{R^5}{5} \end{aligned}$$

Since $\rho \frac{4}{3} \pi R^3 = q$, the magnetic moment becomes $\mu = q\omega R^2 / 5$.

(c) Taking the ratio of the magnetic dipole moment and the angular momentum yields:

$$\gamma_e = \frac{\mu}{L} = \frac{\frac{q\omega R^2}{5}}{\frac{2}{5}mR^2\omega} = \frac{q}{2m}. \text{ Substituting } q = -e \text{ gives: } \gamma_e = -e / (2m).$$

CALCULATE: Not required

ROUND: Not required

DOUBLE-CHECK: The magnetic dipole and the angular momentum should both be quadratic in R , so it is logical that the ratio of these two quantities is independent of R .

28.64.

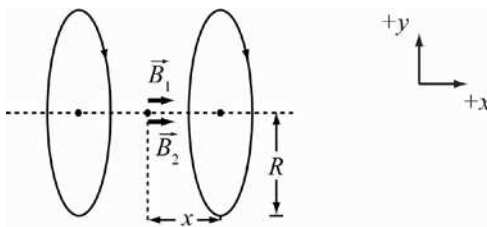

The magnitude of magnetic field due to one of the coils is $B_1 = \frac{\mu_0 i N_1}{2} \frac{R^2}{(x^2 + R^2)^{3/2}}$. Since $B_1 = B_2$, the net magnetic field is $B = B_1 + B_2 = \frac{\mu_0 i N R^2}{(x^2 + R^2)^{3/2}}$. Putting in $x = 0.500$ m, $R = 2.00$ m, $i = 7.00$ A and $N = 50$ yields $B = \frac{(4\pi \cdot 10^{-7} \text{ T m/A})(7.00 \text{ A})(50)(2.00 \text{ m})^2}{[(0.500 \text{ m})^2 + (2.00 \text{ m})^2]^{3/2}} = 2.01 \cdot 10^{-4} \text{ T}$.

28.65.

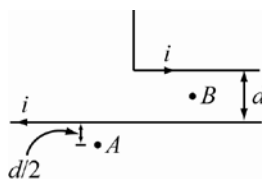

Since the horizontal distance between points A and B is large compared to d , the magnetic field at point B can be approximated by two parallel wires carrying opposite currents. By the right hand rule, the magnetic field at point B is directed into the page from both currents. Since point B is a distance of $d/2$ away from each wire, the magnitude of magnetic field at point B is twice that at point A. So, the strength of the magnetic field at point B is $B = 2(2.00 \text{ mT}) = 4.00 \text{ mT}$.

28.66.

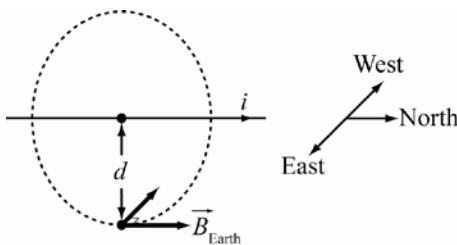

Applying the right hand rule gives the direction of the magnetic field due to the wire at the compass needle in the westward direction. The magnitude of B_{wire} is

$$B = \frac{\mu_0 I}{2\pi d} = \frac{(4\pi \cdot 10^{-7} \text{ T m/A}) \cdot 500.0 \text{ A}}{2\pi \cdot 12.0 \text{ m}} = 8.33 \mu\text{T}.$$

The deflection of the compass needle is $\delta\theta = \arctan\left(\frac{B_{\text{wire}}}{B_{\text{Earth}}}\right) = \arctan\left(\frac{8.33 \mu\text{T}}{40.0 \mu\text{T}}\right) = 11.8^\circ$. The deflection is westward.

- 28.67. The magnetic dipole moment is defined as $\mu = iA = i\pi R^2$. This means the current that produces this magnetic dipole moment is $i = \mu / (\pi R^2)$. Substituting the numerical values gives the current of

$$i = \frac{8.0 \cdot 10^{22} \text{ A m}^2}{\pi(2.5 \cdot 10^6 \text{ m})^2} = 4.07 \cdot 10^9 \text{ A} \approx 4.1 \cdot 10^9 \text{ A}.$$

- 28.68. The potential energy of a current loop in a magnetic field is given by $U = -\vec{\mu} \cdot \vec{B}$. The magnitude of the magnetic dipole moment is $\mu = iA = i\pi R^2$. The direction of the magnetic dipole moment can be determined using the right hand rule. In this case, the magnetic dipole is in the positive z -direction. Therefore, it follows that $\vec{\mu} = i\pi R^2 \hat{z} = 0.10 \text{ A} \cdot \pi \cdot (0.12 \text{ m})^2 = 4.5 \cdot 10^{-3} \hat{z} \text{ A m}^2$. The energy is given by $U = -\vec{\mu} \cdot \vec{B} = (4.5 \cdot 10^{-3} \hat{z} \text{ A m}^2) \cdot (-1.5 \hat{z} \text{ T}) = 6.8 \cdot 10^{-3} \text{ J}$. If the loop can move freely, the loop will rotate such that its magnetic dipole moment aligns with the direction of the magnetic field. This means the magnetic dipole moment is $\vec{\mu} = 4.5 \cdot 10^{-3} (-\hat{z}) \text{ A m}^2$. Thus the minimum energy is $U = -4.5 \cdot 10^{-3} \text{ A m}^2 (-\hat{z}) \cdot (-1.5 \hat{z} \text{ T}) = -6.8 \cdot 10^{-3} \text{ J}$.

- 28.69. The magnitude of magnetic field inside a solenoid is given by $B = \mu_0 in = \mu_0 i(N/L)$. Simplifying this, the number of turns of the wire is $N = BL / (\mu_0 i)$. Putting in the numerical values, $i = 0.20 \text{ A}$, $L = 0.90 \text{ m}$ and

$$B = 5.0 \cdot 10^{-3} \text{ T yields } N = \frac{(5.0 \cdot 10^{-3} \text{ T})(0.90 \text{ m})}{(4\pi \cdot 10^{-7} \text{ T m/A})(0.20 \text{ A})} = 17904 \approx 18000 \text{ turns}.$$

- 28.70.

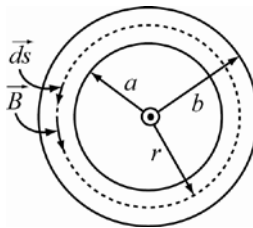

Applying Ampere's Law around a loop as shown in the figure gives $\oint \vec{B} \cdot d\vec{s} = B \oint ds = \mu_0 i_{\text{enc}}$. Thus, the magnetic field is $B = \mu_0 i_{\text{enc}} / (2\pi r)$. The enclosed current is given by $i_{\text{enc}} = i \frac{A_{\text{enc}}}{A_{\text{total}}}$ when A_{enc} is cross sectional area of the shield that is enclosed by the loop and A_{total} is the cross sectional area shield. This means the areas are $A_{\text{enc}} = \pi(r^2 - a^2)$ and $A_{\text{total}} = \pi(b^2 - a^2)$. Thus the magnetic field inside the shield is

$$B = \frac{\mu_0 i}{2\pi r} \left(1 - \frac{r^2 - a^2}{b^2 - a^2} \right) = \frac{\mu_0 i}{2\pi r} \left(\frac{b^2 - r^2}{b^2 - a^2} \right).$$

- 28.71. **THINK:** The torque due to the current in a loop of wire in a magnetic field must balance the torque due to weight.

SKETCH:

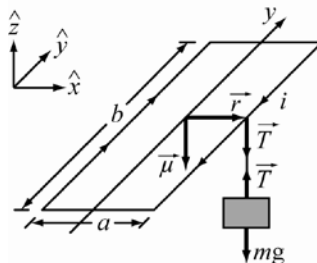

RESEARCH: The torque on a current loop in a uniform magnetic field is given by $\tau_B = \vec{\mu} \times \vec{B} = iN\vec{A} \times \vec{B} = iNA(-\hat{z}) \times \vec{B}$. Using Newton's Second Law, the torque due to the weight is found to be $\tau_w = \vec{r} \times \vec{T} = \left(\frac{1}{2}a\hat{x}\right) \times mg(-\hat{z}) = -\frac{1}{2}amg(\hat{x} \times \hat{z})$.

SIMPLIFY: Since the system is in equilibrium, the net torque must be zero: $\sum \tau = \tau_B + \tau_w = 0$. Thus,

$$\begin{aligned} \tau_B &= -\tau_w \\ -iNA\hat{z} \times \vec{B} &= \frac{1}{2}amg(\hat{x} \times \hat{z}) = -\frac{1}{2}amg(\hat{z} \times \hat{x}). \end{aligned}$$

This means that the magnetic field vector is in positive \hat{x} . Substituting $\vec{B} = B\hat{x}$ gives $iNAB = \frac{1}{2}amg$. After simplifying and using $A = ab$, $\vec{B} = \frac{1}{2} \frac{amg}{iNA} \hat{x} = \frac{1}{2} \frac{amg}{iN(ab)} \hat{x} = \frac{mg}{2iNb} \hat{x}$.

CALCULATE: Substituting the numerical values produces $\vec{B} = \frac{(0.0500 \text{ kg})(9.81 \text{ m/s}^2)}{2(1.00 \text{ A}) \cdot 50 \cdot (0.200 \text{ m})} \hat{x} = 0.02453 \text{ T}$.

ROUND: Three significant figures yields, $\vec{B} = 24.5 \text{ mT}$.

DOUBLE-CHECK: The magnetic force must be in the positive z -direction to balance gravity. By the right hand rule, it can be seen that the magnetic field must point in the positive x -direction for this to occur. This is consistent with the result calculated above. The result is reasonable.

- 28.72. **THINK:** In this problem, the net magnetic field due to two parallel wires is determined by adding the contributions from the wire.

SKETCH:

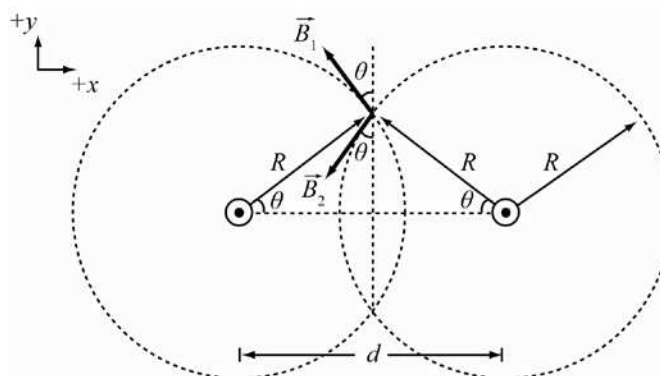

RESEARCH: The magnitude of the magnetic field of a long wire is given by $B = \mu_0 i / (2\pi R)$. The net magnetic field is $\vec{B}_{\text{net}} = \vec{B}_1 + \vec{B}_2$. Because of the symmetry of this problem, the y -component of the magnetic fields cancel out and only the x -component remains. Thus, the net magnetic field becomes

$$\vec{B} = -B \sin \theta \hat{x} - B \sin \theta \hat{x} = -2B \sin \theta \hat{x}$$

$$\vec{B} = \frac{-\mu_0 i}{\pi R} \sin \theta \hat{x}$$

SIMPLIFY: Since $\sin \theta = \frac{\sqrt{R^2 - (d/2)^2}}{R}$, the magnitude of the magnetic field simplifies to

$$B = \frac{\mu_0 i}{\pi R^2} \sqrt{R^2 - \frac{d^2}{4}}$$

CALCULATE: Inserting the numerical values of the parameters gives

$$B = \frac{(4\pi \cdot 10^{-7} \text{ T m/A})(10.0 \text{ A})}{\pi(12.0 \cdot 10^{-2} \text{ m})^2} \sqrt{(12.0 \cdot 10^{-2} \text{ m})^2 - \frac{(20.0 \cdot 10^{-2} \text{ m})^2}{4}} = 1.843 \cdot 10^{-5} \text{ T.}$$

ROUND: Keeping three significant figures, $B = 1.84 \mu\text{T}$.

DOUBLE-CHECK: The magnetic field due to one wire at the same position is $16.7 \mu\text{T}$. It is therefore reasonable that the answer for two wires is slightly larger than this, considering that the y -components cancel out.

28.73. THINK: In this problem the force on a particle due to a magnetic field must balance the force due to gravity.

SKETCH:

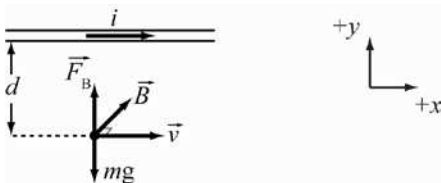

RESEARCH: The force acting on the particle due to the magnetic field is $F_B = qvB \sin \theta$. Since the angle between \vec{v} and \vec{B} is 90.0° , the force due to the magnetic field becomes $F_B = qvB$. This force must balance the gravitational force which is given by $F_g = mg$. Therefore $F_B = F_g$ or $qvB = mg$.

SIMPLIFY: The magnetic field due to the current in the wire is $B = \mu_0 i / (2\pi d)$. The change of the particle is then found to be $q = mg / (vB) = mg 2\pi d / (v\mu_0 i)$.

CALCULATE: Inserting the numerical values gives a charge of

$$q = \frac{(1.00 \cdot 10^{-6} \text{ kg})(9.81 \text{ m/s}^2)2\pi(0.100 \text{ m})}{(1000. \text{ m/s})(4\pi \cdot 10^{-7} \text{ T m/A})(10.0 \text{ A})} = 4.905 \cdot 10^{-4} \text{ C.}$$

ROUND: Rounding the result to 3 significant figures gives $q = 4.91 \cdot 10^{-4} \text{ C}$.

DOUBLE-CHECK: Dimensional analysis confirms the calculation provided the answer in the correct

$$\text{units: } q = \frac{[\text{kg}][\text{m/s}^2][\text{m}]}{[\text{m/s}][\text{T}][\text{m/A}][\text{A}]} = \frac{[\text{kg}][\text{m/s}^2]}{[\text{m/s}][\text{N}/(\text{A m})]} = \frac{[\text{A}][\text{m}]}{[\text{m/s}]} = [\text{A}][\text{s}] = [\text{C}].$$

- 28.74. **THINK:** The torque on a loop of wire in a magnetic field is given by $\vec{\tau} = \vec{\mu} \times \vec{B}$, where $\vec{\mu}$ is the magnetic dipole moment of the wire.

SKETCH:

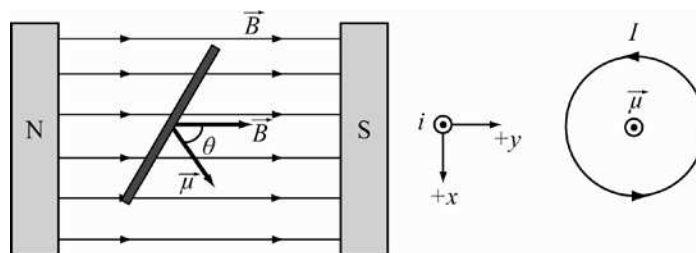

RESEARCH:

(a) Using the right hand rule, the direction of current is counterclockwise as seen by an observer looking in the negative $\vec{\mu}$ direction as shown in the above figure.

(b) Using the magnetic dipole moment $\vec{\mu} = iNA\hat{n}$, the torque on the wire is $\vec{\tau} = iNA\hat{n} \times \vec{B}$, where \hat{n} is a unit vector normal to the loop. Since $|\hat{n} \times \vec{B}| = B\sin\theta$ and $A = \pi R^2$, the magnitude of the torque is $\tau = iN\pi R^2 B\sin\theta$.

SIMPLIFY: From the equation, the number of turns needed to produce τ is $N = \frac{\tau}{\pi i R^2 B \sin\theta}$.

CALCULATE:

(b) Substituting the numerical values of the parameters yields

$$N_1 = \frac{(3.40 \text{ N m})}{\pi(5.00 \text{ A})(5.00 \cdot 10^{-2} \text{ m})^2 (2.00 \text{ T})\sin(60.0^\circ)} = 49.98 = 50. \text{ turns.}$$

(c) Replacing the values of the above R with $R = 2.5 \cdot 10^{-2} \text{ m}$ gives the number of turns

$$N_2 = \frac{(3.40 \text{ Nm})}{\pi(5.00 \text{ A})(2.50 \cdot 10^{-2} \text{ m})^2 (2.00 \text{ T})\sin(60.0^\circ)} = 100. \text{ turns.}$$

ROUND: Not needed.

DOUBLE-CHECK: Since N is inversely proportional to R^2 , the ratio of the results in (b) and (c) is

$$\frac{N_1}{N_2} = \frac{R_2^2}{R_1^2} = \frac{(R_1/2)^2}{R_1^2} = \frac{1}{4} = \frac{50}{200}.$$

- 28.75. **THINK:** Assuming the inner loop is sufficiently small such that the magnetic field due to the larger loop is same across the surface of the smaller loop, the torque on the small loop can be determined by its magnetic moment.

SKETCH:

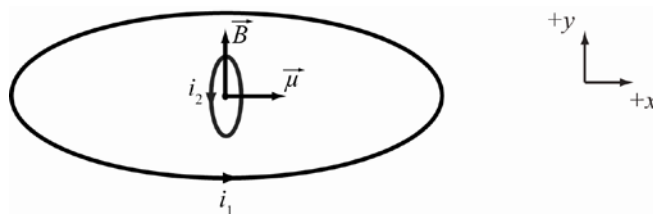

RESEARCH: The torque experienced by the small loop is given by $\vec{\tau} = \vec{\mu} \times \vec{B}$. The magnetic field in the center of the loop is given by $\vec{B} = \frac{\mu_0 i_1}{2R} \hat{y}$. The magnetic dipole moment of the small loop is

$$\vec{\mu} = i_2 \vec{A}_2 = i_2 \pi r^2 \hat{x}.$$

SIMPLIFY: Combining all the above expressions yields the torque.

$$\tau = |\vec{\tau}| = \left| \left(i_2 \pi r^2 \hat{x} \right) \times \left(\frac{\mu_0 i_1}{2R} \hat{y} \right) \right| = \frac{\pi \mu_0 i_1 i_2 r^2}{2R} |\hat{x} \times \hat{y}| = \frac{\pi \mu_0 i_1 i_2 r^2}{2R}$$

CALCULATE: Putting in all the numerical values gives

$$\tau = \frac{\pi (4\pi \cdot 10^{-7} \text{ T m/A}) (14.0 \text{ A}) (14.0 \text{ A}) (0.00900 \text{ m})^2}{2(0.250 \text{ m})} = 1.254 \cdot 10^{-7} \text{ N m}.$$

ROUND: Rounding to 3 significant figures gives, $\tau = 1.25 \cdot 10^{-7} \text{ N m}$.

DOUBLE-CHECK: The units are correct: $\tau = \frac{[\text{T m/A}][\text{A}][\text{A}][\text{m}^2]}{[\text{m}]} = \frac{[\text{N}][\text{A}][\text{m}^2]}{[\text{A}][\text{m}]} = [\text{N m}]$.

28.76. THINK: Two parallel wires carrying currents in the same direction have an attractive force. Two parallel wires carrying currents in opposite directions have a repulsive force.

SKETCH:

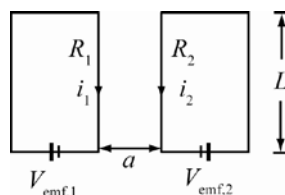

RESEARCH: By considering the direction of *emf* potentials, the currents in the wires have the same direction. Therefore the force between the wires is attractive. The force between the two wires is given by

$$F = \frac{\mu_0 i_1 i_2 L}{2\pi a}.$$

SIMPLIFY: The currents through the wires are given by $i_1 = \frac{V_{\text{emf},1}}{R_1}$ and $i_2 = \frac{V_{\text{emf},2}}{R_2}$. Thus, the force

becomes $F = \frac{\mu_0 V_{\text{emf},1} V_{\text{emf},2} L}{2\pi a R_1 R_2}$. Solving for R_2 gives: $R_2 = \frac{\mu_0 V_{\text{emf},1} V_{\text{emf},2} L}{2\pi a R_1 F}$.

CALCULATE: Substituting the numerical values gives

$$R_2 = \frac{(4\pi \cdot 10^{-7} \text{ T m/A})(9.00 \text{ V})(9.00 \text{ V})(0.250 \text{ m})}{2\pi (0.00400 \text{ m})(5.00 \Omega)(4.00 \cdot 10^{-5} \text{ N})} = 5.063 \Omega.$$

ROUND: Rounding the result to 3 significant figures gives $R_2 = 5.06 \Omega$.

DOUBLE-CHECK: To 1 significant figure, the value of R_2 is the same as R_1 . This is reasonable.

- 28.77. **THINK:** To solve this problem, the forces due to an electric field and a magnetic field are computed separately. The forces are added as vectors to get a net force.

SKETCH:

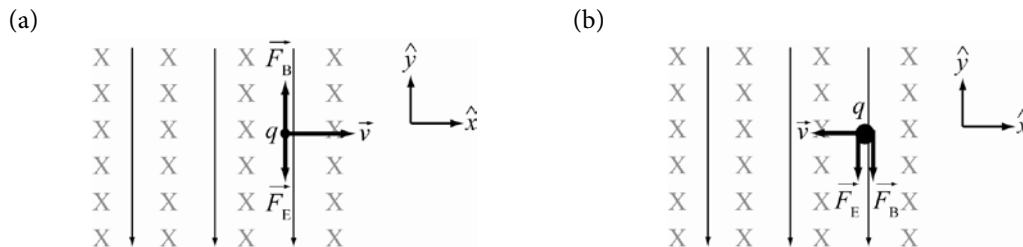

RESEARCH: Using the right hand rule and since the charge of proton is positive, the directions of forces are shown above. The magnitude of the electric force on the proton is $F_E = qE$, and the magnitude of the magnetic force is $F_B = qvB$.

SIMPLIFY:

(a) The acceleration of the proton is $a = \frac{F_{\text{net}}}{m} = \frac{qvB - qE}{m} = \frac{q}{m}(vB - E)$.

(b) The acceleration of the proton if the velocity is reversed is

$$a = \frac{F_{\text{net}}}{m} = -F_B - F_E = \frac{-qvB - qE}{m} = -\frac{q}{m}(vB + E).$$

CALCULATE: Substituting the numerical values yields the acceleration

(a) $a = \frac{1.60 \cdot 10^{-19} \text{ e}}{1.67 \cdot 10^{-27} \text{ kg}} ((200. \text{ m/s})(1.20 \text{ T}) - 1000. \text{ V/m}) = -7.28 \cdot 10^{10} \text{ m/s}^2$

(b) $a = -\frac{1.60 \cdot 10^{-19} \text{ e}}{1.67 \cdot 10^{-27} \text{ kg}} ((200. \text{ m/s})(1.20 \text{ T}) + 1000. \text{ V/m}) = -1.19 \cdot 10^{11} \text{ m/s}^2$

ROUND:

(a) $a = -7.28 \cdot 10^{10} \text{ m/s}^2$

(b) $a = -1.19 \cdot 10^{11} \text{ m/s}^2$

DOUBLE-CHECK: It is expected that the result in (b) is larger than in (a). This is consistent with the calculated values.

- 28.78. **THINK:** The net acceleration of a toy airplane is due to the gravitational acceleration and the magnetic field of a wire. However for this problem, the gravitational force is ignored.

SKETCH:

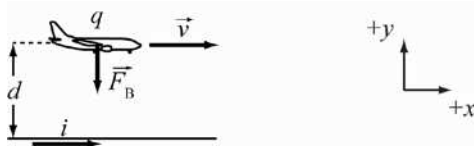

RESEARCH: Using a right hand rule, the magnetic force on the plane is directed toward the wire. The net acceleration of the plane due to the magnetic field is $a = F_B / m = qvB / m$.

SIMPLIFY: Substituting the magnetic field of the wire $B = \mu_0 i / (2\pi d)$ yields $a = \frac{qv\mu_0 i}{2\pi md}$.

CALCULATE: Putting in the numerical values gives the acceleration:

$$a = \frac{(36 \cdot 10^{-3} \text{ C}) \cdot (2.8 \text{ m/s}) (4\pi \cdot 10^{-7} \text{ T m/A}) \cdot (25 \text{ A})}{2\pi (0.175 \text{ kg})(0.172 \text{ m})} = 1.674 \cdot 10^{-5} \text{ m/s}^2.$$

ROUND: Rounding the result to two significant figures gives $a = 1.7 \cdot 10^{-5} \text{ m/s}^2$.

DOUBLE-CHECK: It is expected that the result will be much less than the value of the gravitational acceleration.

- 28.79. THINK:** To do this problem, the inertia of a long thin rod is required. The torque on a wire is also needed. The measure of the angle θ is 25.0° , and the current is $i = 2.00$ A. Let $A = 0.200 \cdot 10^{-4} \text{ m}^2$ and $B = 9.00 \cdot 10^{-2} \text{ T}$.

SKETCH:

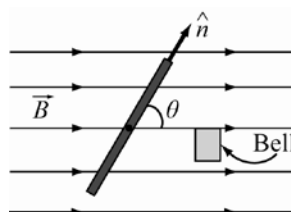

RESEARCH: The magnetic dipole moment of the wire is given by $\vec{\mu} = NiA\hat{n}$.

- (a) The torque on the wire is $\vec{\tau} = \vec{\mu} \times \vec{B}$. The magnitude of this torque is $\tau = \mu B \sin\theta = NiAB \sin\theta$.
 (b) The angular velocity of the rod when it strikes the bell is determined by using conservation of energy, that is, $E_i = E_f$ or $U_i + K_i = U_f + K_f$.

SIMPLIFY:

- (a) $\tau = \mu B \sin\theta = NiAB \sin\theta$.
 (b) Since $K_i = 0$, the final kinetic energy is

$$K_f = U_i - U_f$$

$$\frac{1}{2}I\omega^2 = -\mu B \cos\theta + \mu B \cos(0^\circ) = -\mu B \cos\theta + \mu B = \mu B(1 - \cos\theta)$$

Thus the angular velocity is $\omega = \sqrt{\frac{2\mu B(1 - \cos\theta)}{I}} = \sqrt{\frac{2NiAB(1 - \cos\theta)}{(1/12)mL^2}}$, using $I = \frac{1}{12}mL^2$, the inertia of a thin rod.

CALCULATE: Putting in the numerical values gives the following values.

- (a) $\tau = (70)(2.00 \text{ A})(0.200 \cdot 10^{-4} \text{ m}^2)(9.00 \cdot 10^{-2} \text{ T})\sin(25.0^\circ) = 1.06 \cdot 10^{-4} \text{ N m}$
 (b) $\omega = \left[\frac{2(70)(2.00 \text{ A})(0.200 \cdot 10^{-4} \text{ m}^2)(9.00 \cdot 10^{-2} \text{ T})(1 - \cos 25.0^\circ)}{(1/12)(0.0300 \text{ kg})(0.0800 \text{ m})^2} \right]^{1/2} = 1.72 \text{ rad/s}$

ROUND: Rounding to 3 significant figures yields $\tau = 1.06 \cdot 10^{-4} \text{ N m}$, $\omega = 1.72 \text{ rad/s}$.

DOUBLE-CHECK: The torque should have units of Newton-meters, while the angular velocity should have units of radians per second.

- 28.80. THINK:** Using a right hand rule, the sum of the magnetic fields of two parallel wires carrying opposite currents cannot be zero between the two wires.

SKETCH:

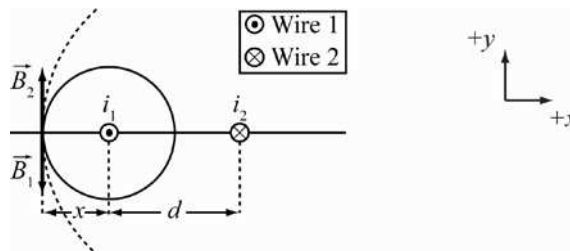

RESEARCH: The magnitude of the magnetic field of a long wire is $B = \mu_0 i / (2\pi R)$. Since $i_1 < i_2$ and i_1 is in an opposite direction to i_2 , using the right hand rule, it is found that the location of the zero magnetic field must be to the left of the left-hand wire, as shown in the figure. Assuming the location is a distance x to the left of the left-hand wire, then the net magnetic field is $B_{\text{net}} = B_2 - B_1 = \frac{\mu_0 i_2}{2\pi(x+d)} - \frac{\mu_0 i_1}{2\pi x} = 0$.

SIMPLIFY: Solving for x yields

$$\frac{i_2}{x+d} = \frac{i_1}{x} \Rightarrow xi_2 = i_1x + i_1d \Rightarrow x = \frac{i_1d}{i_2 - i_1}$$

Since $i_2 = 2i_1$,

$$x = \frac{i_1d}{2i_1 - i_1} = d.$$

CALCULATE: Not required.

ROUND: Not required.

DOUBLE-CHECK: This result is expected since the ratio of $i_2 / i_1 = 2$. This means the ratio of distances is $\frac{d_2}{d_1} = \frac{2d}{d} = 2$ also.

28.81. THINK: In order for a coil to float in mid-air, the downward force of gravity must be balanced an upward force due to the current loop in the magnetic field.

SKETCH:

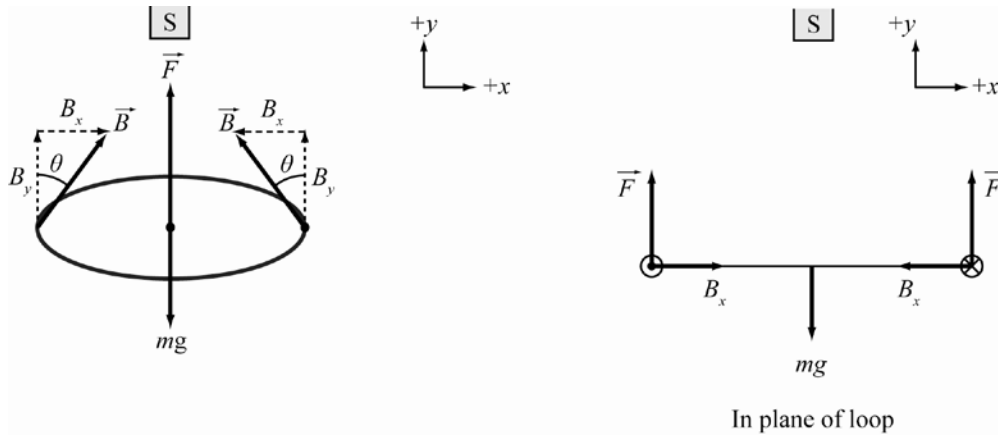

RESEARCH: By using right-hand rule 1, the direction of the forces can be determined. For the y -component B_y of the magnetic field the force due to the current is in the radial direction of the coil. Therefore, this component cannot be responsible for levitating the coil. For the x -component B_x of the magnetic field, with a counterclockwise current as viewed from the bar magnet, the resulting force is in the y -direction, towards the bar magnet (see figure on right). This is the correct direction for balancing the weight of the coil. The magnitude of the y -component of the force on an element dl is $dF_y = Ni |d\vec{l} \times \vec{B}_x| \sin\theta = NiB \sin\theta dl$. Thus the total magnetic force on the current loop is

$$F_y = \int_0^{2\pi R} NiB \sin\theta dl. \text{ Newton's Second Law requires that } F_y = mg.$$

SIMPLIFY: The integral simplifies to: $F_y = 2\pi RNiB \sin\theta$. Therefore,

$$2\pi RNiB \sin\theta = mg \Rightarrow i = \frac{mg}{2\pi RN B \sin\theta}.$$

CALCULATE: Substituting in the numerical values yields

$$i = \frac{(10.0 \cdot 10^{-3} \text{ kg})(9.81 \text{ m/s}^2)}{2\pi(5.00 \cdot 10^{-2} \text{ m})10.0(0.0100 \text{ T})\sin(45.0^\circ)} = 4.416 \text{ A.}$$

ROUND: To 3 significant figures, the current is $i = 4.42 \text{ A}$, counterclockwise as viewed from the bar magnet.

DOUBLE-CHECK: It takes large currents to generate strong magnetic forces. A current of 4 A is realistic to levitate a 10 g mass.

28.82. THINK: In this problem, Ampere's Law is applied on three different circular loops.

SKETCH:

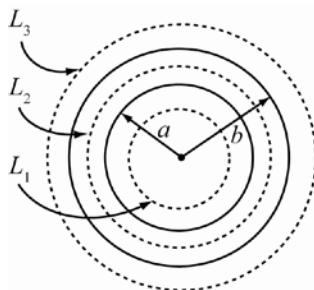

RESEARCH: Loops L_1 , L_2 and L_3 are Amperian loops.

(a) For distances $r < a$, applying Ampere's Law on the loop L_1 , gives $\oint \vec{B} \cdot d\vec{s} = B(2\pi r) = \mu_0 i_{\text{enc}}$. Since $i_{\text{enc}} = 0$, the field is also zero, $B = 0$.

(b) For distances r between a and b , applying Ampere's law on the loop L_2 yields

$$\oint \vec{B} \cdot d\vec{s} = B(2\pi r) = \mu_0 i_{\text{enc}}. \text{ The enclosed current is given by } i_{\text{enc}} = A_{\text{enc}} i / A \text{ or } i_{\text{enc}} = \frac{\pi(r^2 - a^2)}{\pi(b^2 - a^2)} i = \frac{r^2 - a^2}{b^2 - a^2} i.$$

(c) For distances $r > b$, applying Ampere's Law on L_3 gives $B = \frac{\mu_0 i_{\text{enc}}}{2\pi r} = \frac{\mu_0 i}{2\pi r}$, since $i_{\text{enc}} = i$.

SIMPLIFY: Thus, the magnetic field is $B = \frac{\mu_0 i}{2\pi r} \frac{(r^2 - a^2)}{(b^2 - a^2)}$.

CALCULATE: Putting in the numerical values gives

(a) $B = 0$

$$(b) B = \frac{(4\pi \cdot 10^{-7} \text{ T m/A}) \cdot (0.100 \text{ A})}{2\pi(6.50 \cdot 10^{-2} \text{ m})} \left[\frac{(6.50 \text{ cm})^2 - (5.00 \text{ cm})^2}{(7.00 \text{ cm})^2 - (5.00 \text{ cm})^2} \right] = 2.212 \cdot 10^{-7} \text{ T}$$

$$(c) B = \frac{(4\pi \cdot 10^{-7} \text{ T m/A}) \cdot (0.100 \text{ A})}{2\pi(9.00 \cdot 10^{-2} \text{ m})} = 2.222 \cdot 10^{-7} \text{ T}$$

ROUND: Keeping 3 significant figures yields the following results for (b) and (c). Note that the value found in (a) is precise. (a) $B = 0$ (b) $B = 2.21 \cdot 10^{-7} \text{ T}$ (c) $B = 2.22 \cdot 10^{-7} \text{ T}$

DOUBLE-CHECK: The units of the calculated values are T, which is appropriate for magnetic fields.

- 28.83. **THINK:** To solve this problem, the current enclosed by an Amperian loop must be determined.
SKETCH:

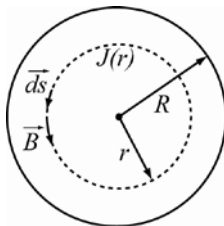

RESEARCH: Applying Ampere's Law on a loop as shown above gives $\oint \vec{B} \cdot d\vec{s} = B(2\pi r) = \mu_0 i_{\text{enc}}$. i_{enc} is the current enclosed by the Amperian loop, that is $i_{\text{enc}} = \int \int J(r) dA = \int_0^{2\pi} \int_0^r J(r') r' dr' d\theta$.

SIMPLIFY: Since $J(r)$ is a function of r only, the above integral becomes $i_{\text{enc}} = 2\pi \int_0^r J(r') r' dr'$. Substituting $J(r) = J_0(1 - r/R)$ yields

$$i_{\text{enc}} = 2\pi J_0 \int_0^r \left[r' - \frac{r'^2}{R} \right] dr' = 2\pi J_0 \left[\frac{r'^2}{2} - \frac{r'^3}{3R} \right]_0^r = 2\pi J_0 \left[\frac{r^2}{2} - \frac{r^3}{3R} \right].$$

Thus, the magnetic field is $B = \frac{\mu_0 2\pi J_0}{2\pi r} \left[\frac{r^2}{2} - \frac{r^3}{3R} \right] = \mu_0 J_0 \left[\frac{r}{2} - \frac{r^2}{3R} \right]$.

CALCULATE: Not required.

ROUND: Not required.

DOUBLE-CHECK: The form of the answer is reasonable.

- 28.84. **THINK:** The maximum torque on a circular wire in a magnetic field is when its magnetic moment is perpendicular to the magnetic field vector.
SKETCH:

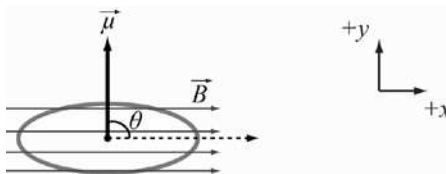

RESEARCH: The torque on the circular wire is given by $\vec{\tau} = \vec{\mu} \times \vec{B}$. The magnitude of the torque is $\tau = \mu B \sin \theta$ where θ is the angle between $\vec{\mu}$ and \vec{B} .

SIMPLIFY:

- (a) The maximum torque is when $\theta = 90^\circ$, that is, $\tau = \mu B$. Using $\mu = iA = i\pi R^2$, the torque becomes

$$\tau = i\pi R^2 B.$$

- (b) The magnetic potential energy is given by $U = -\mu B \cos \theta$. The maximum and the minimum potential energies are when $\theta = 180^\circ$ and $\theta = 0^\circ$, that is, $U_{\text{max}} = +\mu B$ and $U_{\text{min}} = -\mu B$.

CALCULATE: (a) Inserting the numerical values gives the torque:

$$\tau = (3.0 \text{ A})\pi(5.0 \cdot 10^{-2} \text{ m})^2(5.0 \cdot 10^{-3} \text{ T}) = 1.18 \cdot 10^{-4} \text{ N m}.$$

- (b) Since the values of μB is the same as in (a), the range of the potential energy is

$$\Delta U = U_{\text{max}} - U_{\text{min}} = 2\mu B = 2 \cdot 1.2 \cdot 10^{-4} \text{ J} = 2.4 \cdot 10^{-4} \text{ J}.$$

ROUND: Keeping only two significant figures yields $\tau = 1.2 \cdot 10^{-4} \text{ N m}$ and $\Delta U = 2.4 \cdot 10^{-4} \text{ J}$.

DOUBLE-CHECK: The change in potential is a change in energy, so it is appropriate that the final answer have joules as units.

Multi-Version Exercises

Exercises 28.85–28.87 The magnetic field at the center of an arc of radius R subtended by an angle Φ is

$$B_{\Phi} = \int dB = \int_0^{\Phi} \frac{\mu_0}{4\pi} \frac{iRd\phi}{R^2} = \frac{\mu_0 i \Phi}{4\pi R}.$$

In this loop we have three sections:

1: $R = r$, $\Phi = \pi/2$

2: $R = 2r$, $\Phi = \pi/2$

3: $R = 3r$, $\Phi = \pi$.

The segments running directly toward/away from point P have no effect. So the magnetic field at P is

$$B = B_1 + B_2 + B_3 = \frac{\mu_0 i \left(\frac{\pi}{2}\right)}{4\pi(r)} + \frac{\mu_0 i \left(\frac{\pi}{2}\right)}{4\pi(2r)} + \frac{\mu_0 i (\pi)}{4\pi(3r)} = \frac{\mu_0 i}{8r} + \frac{\mu_0 i}{16r} + \frac{\mu_0 i}{12r} = \frac{6\mu_0 i}{48r} + \frac{3\mu_0 i}{48r} + \frac{4\mu_0 i}{48r} = \frac{13\mu_0 i}{48r}.$$

28.85. $B = \frac{13\mu_0 i}{48r} = \frac{13(4\pi \cdot 10^{-7} \text{ T m/A})(3.857 \text{ A})}{48(1.411 \text{ m})} = 9.303 \cdot 10^{-7} \text{ T}$

28.86. $B = \frac{13\mu_0 i}{48r}$
 $r = \frac{13\mu_0 i}{48B} = \frac{13(4\pi \cdot 10^{-7} \text{ T m/A})(3.961 \text{ A})}{48(7.213 \cdot 10^{-7} \text{ T})} = 1.869 \text{ m}$

28.87. $B = \frac{13\mu_0 i}{48r}$
 $i = \frac{48rB}{13\mu_0} = \frac{48(2.329 \text{ m})(5.937 \cdot 10^{-7} \text{ T})}{13(4\pi \cdot 10^{-7} \text{ T m/A})} = 4.063 \text{ A}$

Exercises 28.88–28.90 The magnetic field inside a toroidal magnet is given by $B = \frac{\mu_0 Ni}{2\pi r}$.

28.88. $B = \frac{\mu_0 Ni}{2\pi r}$
 $N = \frac{2\pi r B}{\mu_0 i} = \frac{2\pi(1.985 \text{ m})(66.78 \cdot 10^{-3} \text{ T})}{(4\pi \cdot 10^{-7} \text{ T m/A})(33.45 \text{ A})} = 19,814$

To four significant figures, the toroid has 19,810 turns.

28.89. $B = \frac{\mu_0 Ni}{2\pi r}$
 $i = \frac{2\pi r B}{\mu_0 N} = \frac{2\pi(1.216 \text{ m})(78.30 \cdot 10^{-3} \text{ T})}{(4\pi \cdot 10^{-7} \text{ T m/A})(22,381)} = 21.27 \text{ A}$

28.90. $B = \frac{\mu_0 Ni}{2\pi r} = \frac{(4\pi \cdot 10^{-7} \text{ T m/A})(24,945)(49.13 \text{ A})}{2\pi(1.446 \text{ m})} = 0.1695 \text{ T} = 169.5 \text{ mT}$