

6

Electric Induction Phenomena

6.1 Fundamental Equations

The fundamental laws governing electric induction problems are those in (PIII.4)

$$\begin{cases} \text{curl } \mathbf{H} = \mathbf{J} + \frac{\partial \mathbf{D}}{\partial t} \\ \text{div } \mathbf{D} = \rho \\ \text{curl } \mathbf{E} \approx 0 \end{cases} \quad (6.1)$$

together with the constitutive relations concerning $\mathbf{D}(\mathbf{E})$ and $\mathbf{J}(\mathbf{E})$.

While in Chapter 5 we were concerned with \mathbf{E} fields originated by time-varying \mathbf{B} fields, now we focus on the reverse situation, that is \mathbf{B} fields originated by time-varying \mathbf{E} fields.

6.2 Displacement Current, Generalized Ampère's Law

The reason why Maxwell's equations bear his name is essentially due to his speculative theoretical consideration that the equation $\text{curl } \mathbf{H} = \mathbf{J}$ (based on Ampère's previous discoveries) was an incomplete statement.

Magnetic induction phenomena (which had been known since Faraday's experiments) should have, expectedly, a natural dual counterpart consisting of electric induction phenomena. To accommodate this expectation Maxwell added to the conduction current density \mathbf{J} a new contribution, the so-called displacement current density $\partial \mathbf{D} / \partial t$. With the introduction of this new term into the electromagnetic equations, the latter acquired a type of symmetry that was clearly missing. Since time-varying magnetic fields can give rise to electric fields, time-varying electric fields will likewise give rise to magnetic fields.

The speculative introduction by Maxwell of the displacement current density came to have far-reaching consequences. If the term $\partial \mathbf{D} / \partial t$ did not really exist, our world would not be like it is. It would be dark with no light at all; TV, mobile phones and the Internet would be meaningless words. (We will return to this topic in Part IV when dealing with electromagnetic waves.) The experimental proof that the displacement current was not simply

an interesting speculation but real came only 35 years after Maxwell conceived it. The experimental work that revealed the existence of $\partial\mathbf{D}/\partial t$ was conducted by Hertz in 1889.

The equation

$$\text{curl } \mathbf{H} = \mathbf{J} + \frac{\partial\mathbf{D}}{\partial t} \tag{6.2}$$

shows that a magnetic field can be produced indistinctly by both current densities \mathbf{J} and $\partial\mathbf{D}/\partial t$ – see Figure 6.1.

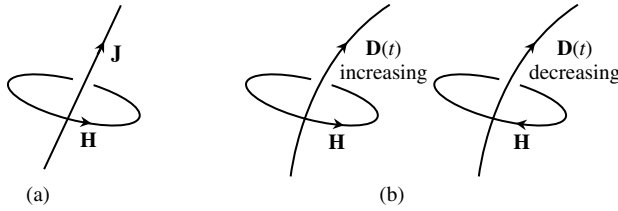

Figure 6.1 Magnetic fields can be originated either by conduction currents (a), or by displacement currents (b)

For purely stationary fields (Chapter 4), the integration of $\text{curl } \mathbf{H} = \mathbf{J}$ led in (4.3) to Ampère’s law:

$$\oint_S \mathbf{H} \cdot d\mathbf{s} = \int_{S_s} \mathbf{J} \cdot \mathbf{n}_S dS$$

For time-varying fields the above result can be generalized by writing

$$\oint_S \mathbf{H} \cdot d\mathbf{s} = \int_{S_s} \left(\mathbf{J} + \frac{\partial\mathbf{D}}{\partial t} \right) \cdot \mathbf{n}_S dS \tag{6.3}$$

where the geometric entities \mathbf{s} , S_s and \mathbf{n}_S should now be rather familiar to you (so often have we made use of the Stokes theorem).

6.3 Charge Continuity Equation

Let us apply the *divergence* operator to (6.2). Taking into account that $\text{div curl} \equiv 0$, and that $\text{div } \mathbf{D} = \rho$, you can easily get

$$0 = \text{div} \left(\mathbf{J} + \frac{\partial\mathbf{D}}{\partial t} \right) \rightarrow \text{div } \mathbf{J} + \frac{\partial}{\partial t} \text{div } \mathbf{D} \rightarrow \text{div } \mathbf{J} = -\frac{\partial\rho}{\partial t} \tag{6.4}$$

The result in (6.4) – the so-called charge continuity equation – shows that \mathbf{J} lines being closed is not an intrinsic property of conduction currents ($\text{div } \mathbf{J} \neq 0$). Conduction currents can actually be interrupted as far as they can be continued through displacement currents.

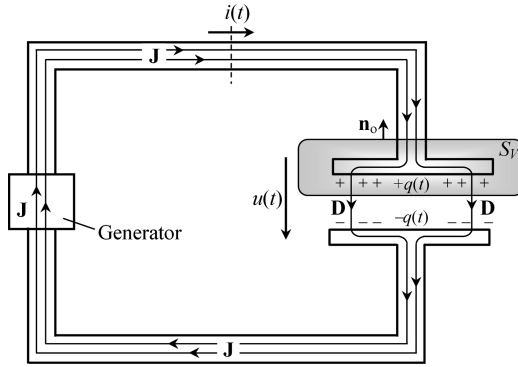

Figure 6.2 Time-varying conduction currents in the conductors are interrupted at the capacitor where they continue in the form of displacement currents

This idea is illustrated in Figure 6.2 where a closed circuit consisting of a generator, a pair of wires and a capacitor is shown.

Now, let us proceed to the volume integration of (6.4) considering the volume V encircling the upper plate of the capacitor in Figure 6.2:

$$\int_V \operatorname{div} \left(\mathbf{J} + \frac{\partial \mathbf{D}}{\partial t} \right) dV = 0 \rightarrow \int_V \operatorname{div} \mathbf{J} dV = -\frac{d}{dt} \int_V \rho dV \quad (6.5a)$$

Making use of the Gauss theorem we get

$$\int_{S_V} \mathbf{J} \cdot \mathbf{n}_o dS = -\frac{d}{dt} \underbrace{\int_V \rho dV}_{q(t)} \quad (6.5b)$$

where $q(t)$ is the electric charge accumulated on the conductor inside volume V .

According to the reference direction assigned to the conduction current $i(t)$, we finally get

$$i(t) = \frac{dq(t)}{dt} \quad (6.6)$$

Making use of the capacitance concept, $q = Cu$, we can rewrite (6.6) as

$$i(t) = C \frac{du(t)}{dt} \quad (6.7)$$

A word of caution is necessary here. If, for some reason, one of the reference directions for $i(t)$ or $u(t)$, shown in Figure 6.2, happens to be reversed, then a minus sign will need to be incorporated into (6.7). This is usually forgotten and may be the source of several mistakes.

A second word of caution: you have probably heard that capacitors can be used to block direct currents, or, in other words, that stationary currents are not allowed to flow in a circuit where a capacitor is included. Well, this is only half true!

If a continuously rising voltage is applied to a capacitor $u(t) = kt$, with k a constant, then from (6.7) you will get $i(t) = I = Ck = \text{constant}$. Therefore you can see that while the capacitor voltage is allowed to increase steadily, you will get a direct current in the circuit. The problem is that, in reality, $u(t)$ cannot increase indefinitely (especially because of breakdown phenomena).

6.4 Revisiting the Current Intensity Concept

Contrary to what happened with stationary fields, we now have $\text{div } \mathbf{J} \neq 0$.

This new circumstance does affect the concept of current intensity in a conductor as originally introduced in Chapter 3. To illustrate the problem, consider Figure 6.3, where one conductor runs parallel to a conducting ground. The surrounding medium is a perfect insulator. A time-varying voltage is applied between the conductors.

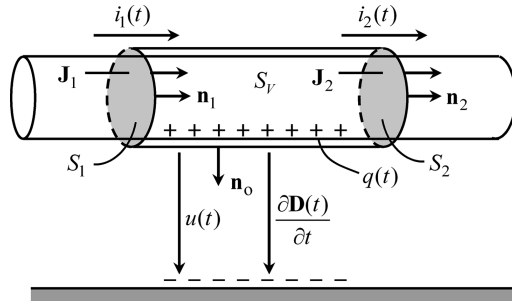

Figure 6.3 For time-varying regimes, the current intensity in a conductor varies along the length of the conductor, $i_1(t) \neq i_2(t)$. For evaluating $i(t)$, a clear specification of the conductor’s cross-section being considered is required

If you apply (6.5) to the closed surface S_V intersecting the conductor at S_1 and S_2 , you get

$$\left\{ \begin{aligned} \int_{S_V} \mathbf{J} \cdot \mathbf{n}_o \, dS &= \int_{S_2} \mathbf{J}_2 \cdot \mathbf{n}_2 \, dS - \int_{S_1} \mathbf{J}_1 \cdot \mathbf{n}_1 \, dS = i_2(t) - i_1(t) \\ - \int_{S_V} \frac{\partial \mathbf{D}}{\partial t} \cdot \mathbf{n}_o \, dS &= - \frac{dq(t)}{dt} \end{aligned} \right.$$

By equating the equations above you will see that $i_1(t) \neq i_2(t)$, that is

$$i_1(t) - i_2(t) = dq(t)/dt \tag{6.8}$$

where $q(t)$ is the conductor’s time-varying charge in the region between S_1 and S_2 .

The difference between the current intensities in the same conductor, but measured at two distinct cross-sections, is justified by the flow of displacement current between the conductor and the ground.

As the magnitude and time rate of the applied voltage increase, the term dq/dt increases, and as a result the discrepancy between i_1 and i_2 becomes more and more important.

Hence, you can see that for an unambiguous definition of the current intensity $i(t)$ in a conductor, you ought to specify clearly the particular cross-section S where its evaluation takes place. For slow time-varying phenomena this requirement is ordinarily dropped, since $dq/dt \approx 0$.

6.5 Application Example (Capacitor Self-Discharge)

A parallel-plate capacitor of area S and thickness δ is connected to a DC generator with voltage U_0 . The capacitor's dielectric medium is characterized by its permittivity ϵ and conductivity σ . At $t = 0$ the capacitor is disconnected from the generator and from there on the capacitor starts its self-discharge process.

Assume that the electric field inside the dielectric medium is uniform (small δ).

Questions

- Q₁ Find the initial value of the electric field intensity E_0 .
- Q₂ Find the evolution of $E(t)$ for $t > 0$.
- Q₃ Determine the conduction current density and the displacement current density inside the capacitor for $t > 0$.
- Q₄ Find the magnetic field inside the discharging capacitor.

Solutions

- Q₁ For the case of uniform fields we have $U_0 = E_0 \delta \rightarrow E_0 = U_0/\delta$.
- Q₂ Consider the application of (6.5b) to the closed surface S_V containing the upper plate of the capacitor (Figure 6.4).

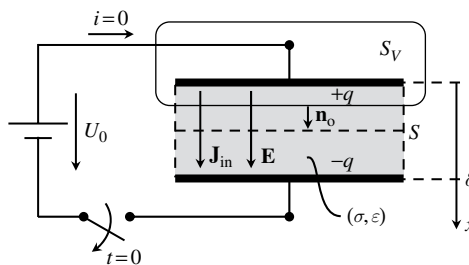

Figure 6.4 Application of the charge continuity equation to the analysis of the capacitor self-discharge process. Note that the insulation medium that fills the capacitor is imperfect ($\sigma \neq 0$)

For $t > 0$ the external conduction current density \mathbf{J}_{ex} is zero; however, inside the imperfect dielectric medium an internal conduction current density \mathbf{J}_{in} exists,

$$\mathbf{J}_{\text{in}}(t) = \sigma \mathbf{E}(t) = \sigma E(t) \vec{e}_x$$

then we have

$$\underbrace{\int_{S_V} \mathbf{J}_{\text{in}} \cdot \mathbf{n}_0 \, dS}_{\sigma SE(t)} = -\frac{d}{dt} q(t)$$

For the case of uniform fields, the electric charge $q(t)$ is the product of the surface charge density $w(t)$ and the plate area $q = wS$. But, from Chapter 2, $w = \varepsilon E$. Therefore we find, for the electric field inside the capacitor,

$$\sigma E(t) + \varepsilon \frac{dE(t)}{dt} = 0$$

This is a homogeneous first-order linear equation with constant coefficients whose solution is a decaying exponential function

$$E(t) = E_0 \exp\left(-\frac{\sigma}{\varepsilon} t\right) \quad (6.9)$$

The constant $\tau = \varepsilon/\sigma$ is usually termed the relaxation time. Depending on the dielectric medium, this relaxation time can go from seconds to hours.

Q₃ Internal conduction current density:

$$\mathbf{J}_{\text{in}} = \sigma E_0 \exp\left(-\frac{\sigma}{\varepsilon} t\right) \vec{e}_x$$

Displacement current density:

$$\frac{d\mathbf{D}}{dt} = \varepsilon \frac{dE}{dt} \vec{e}_x = -\sigma E_0 \exp\left(-\frac{\sigma}{\varepsilon} t\right) \vec{e}_x$$

Q₄ As for the total current density inside the dielectric medium, we find

$$\mathbf{J}_{\text{in}} + \frac{\partial \mathbf{D}}{\partial t} = 0$$

and, consequently, from (6.2), no net magnetic field is originated, $\mathbf{H} = 0$.

6.6 Voltages and Currents in Electrically Multicoupled Systems

Consider a set of $N + 1$ wires immersed in a perfectly insulating dielectric medium, one of them being taken as the reference conductor (0) – see cross-sectional view in Figure 6.5.

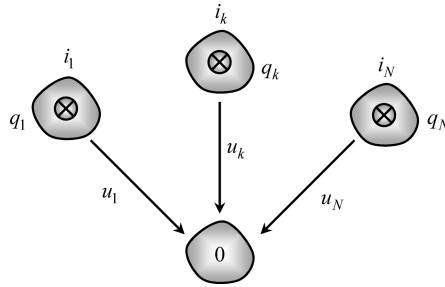

Figure 6.5 In a multi-wire system, the voltages of all the conductors contribute to the current intensity in any given conductor of the system, $i_k = \sum C_{kj} du_j/dt$

If time-varying voltages are applied between conductors, conduction currents will flow along them, and displacement currents will flow across the dielectric medium.

Denoting the conductor charges by $q_1(t), \dots, q_k(t), \dots, q_N(t)$, we have from (6.6)

$$i_k(t) = \frac{dq_k(t)}{dt} \quad (6.10a)$$

Since charges and voltages, in multiconductor systems, are related by capacitance coefficients –recall (2.43) and (2.44) from Chapter 2 – then we can rewrite (6.10a) as

$$i_k(t) = C_{k1} \frac{du_1(t)}{dt} + \dots + C_{kk} \frac{du_k(t)}{dt} + \dots + C_{kN} \frac{du_N(t)}{dt} \quad (6.10b)$$

In compact matrix format we get

$$[i(t)] = [C] \frac{d}{dt} [u(t)] \quad (6.11)$$

where the column matrix $[i(t)]$ gathers the conduction currents flowing along the wires, and the column matrix $[u(t)]$ gathers the wire voltages. The square symmetric matrix $[C]$ is the capacitance matrix whose properties were discussed in Chapter 2.

If the dielectric is not a perfectly insulating medium, leakage conduction currents will also flow in the dielectric. In that case we must substitute (6.12) for (6.11):

$$[i(t)] = [G][u(t)] + [C] \frac{d}{dt} [u(t)] \quad (6.12)$$

where the first term on the right-hand side of (6.12) accounts for the perturbation due to leakage currents. The square symmetric matrix $[G]$ is the system conductance matrix.

If the dielectric medium is homogeneous, characterized by parameters ϵ and σ , the relationship between $[G]$ and $[C]$ is trivial:

$$[G] = \frac{\sigma}{\epsilon} [C] \quad (6.13)$$

See (3.11) in Chapter 3 and Problem 3.9.6.

6.7 Proposed Homework Problems

Problem 6.7.1

A generator voltage $u(t)$ is applied to two series-connected capacitors whose capacitances are C_1 and C_2 – see Figure 6.6. The capacitors are initially discharged. The generator voltage has the shape of a trapezoidal pulse.

Assume the ordinary approximations valid for slow time-varying regimes.

Data: $C_1 = 4\ \mu\text{F}$, $C_2 = 6\ \mu\text{F}$, $T = 1\ \text{ms}$, $U = 15\ \text{V}$.

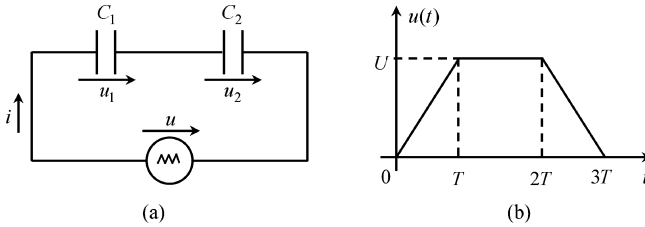

Figure 6.6 Two series-connected capacitors (a) subjected to a trapezoidal pulse voltage (b)

Q₁ Write the governing equations of the system.

Q₂ Determine $i(t)$.

Q₃ Determine $u_1(t)$ and $u_2(t)$.

Answers

Q₁ $i = dq_1/dt = C_1 du_1/dt$; $i = dq_2/dt = C_2 du_2/dt$; $u = u_1 + u_2$

$$\frac{i}{C_1} + \frac{i}{C_2} = \frac{d}{dt} \underbrace{(u_1 + u_2)}_u \rightarrow i(t) = \underbrace{\left(\frac{C_1 C_2}{C_1 + C_2} \right)}_c \frac{du(t)}{dt}$$

$$\begin{cases} C_1 u_1 = C_2 u_2 \\ u_1 + u_2 = u \end{cases} \rightarrow \begin{cases} u_1 = \frac{C}{C_1} u \\ u_2 = \frac{C}{C_2} u \end{cases}$$

Q₂

$$i(t) = \begin{cases} +CU/T = 36\ \text{mA}, & \text{for } 0 < t < T \\ 0, & \text{for } T < t < 2T \\ -CU/T = -36\ \text{mA}, & \text{for } 2T < t < 3T \end{cases}$$

Note that in the interval from T to $2T$ the electric field remains time invariant and electric induction phenomena do not occur ($\mathbf{H} = 0$).

Q₃

$$\begin{cases} u_1(t) = 0.6 \times u(t) \\ u_2(t) = 0.4 \times u(t) \end{cases}$$

Problem 6.7.2

A sinusoidal voltage $u(t)$ is applied to two parallel-connected capacitors whose capacitances are C_1 and C_2 – see Figure 6.7. The capacitors are initially discharged.

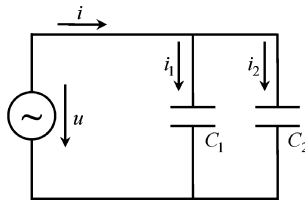

Figure 6.7 Two parallel-connected capacitors subjected to a sinusoidal voltage

The current intensity i_1 is known and is given by $i_1(t) = I_1 \cos(\omega t)$.

Assume the ordinary approximations valid for slow time-varying regimes.

Data: $C_1 = 4 \mu\text{F}$, $C_2 = 6 \mu\text{F}$, $I_1 = 40 \text{ mA}$, $\omega = 1 \text{ krad/s}$.

Q₁ Write the governing equations of the system.

Q₂ Determine $u(t)$.

Q₃ Determine $i_2(t)$ and $i(t)$.

Answers

Q₁ $u(t) = \frac{1}{C_1} \int i_1(t) dt$; $i_2(t) = C_2 \frac{du(t)}{dt}$; $i(t) = i_1(t) + i_2(t)$

Q₂ $u(t) = U \sin(\omega t)$, with $U = I_1 / (\omega C_1) = 10 \text{ V}$.

Q₃ $i_2(t) = I_2 \cos(\omega t)$, with $I_2 = \omega C_2 U = 60 \text{ mA}$.

$i(t) = I \cos(\omega t)$, with $I = I_1 + I_2 = 100 \text{ mA}$.

Problem 6.7.3

A printed circuit board consisting of three conducting lands on the surface of a dielectric board above a reference conducting ground plane is shown in Figure 6.8.

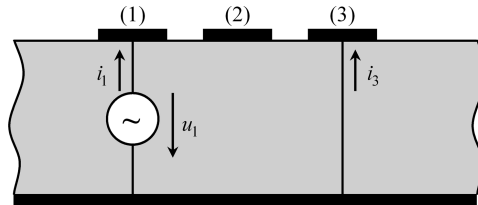

Figure 6.8 Front view of a printed circuit board with three lands on a dielectric over a ground plane

All lands are left open at the far end of the board. As for the near end, the situation is described as follows: land 1 is driven by a voltage u_1 , land 2 is left open ($i_2 = 0$) and land 3 is short-circuited to ground ($u_3 = 0$). The conductor system is characterized by a symmetric capacitance matrix

$$[C] = \begin{bmatrix} C_{11} & C_{12} & C_{13} \\ C_{21} & C_{22} & C_{23} \\ C_{31} & C_{32} & C_{33} \end{bmatrix}$$

The generator voltage is a sinusoidal function, $u_1(t) = U_1 \sin(\omega t)$.

Q₁ Obtain the governing equations of the system.

Q₂ Determine $u_2(t)$. Determine $i_1(t)$ and $i_3(t)$.

Answers

Q₁ From (6.11), with $u_3 = 0$, we get

$$\begin{cases} i_1 = C_{11} \frac{du_1}{dt} + C_{12} \frac{du_2}{dt} \\ 0 = C_{21} \frac{du_1}{dt} + C_{22} \frac{du_2}{dt} \\ i_3 = C_{31} \frac{du_1}{dt} + C_{32} \frac{du_2}{dt} \end{cases}$$

Q₂

$$u_2(t) = -\frac{C_{21}}{C_{22}} u_1(t)$$

$$i_1(t) = \left(C_{11} - \frac{C_{12}^2}{C_{22}} \right) \frac{du_1(t)}{dt} = \omega U_1 \left(C_{11} - \frac{C_{12}^2}{C_{22}} \right) \cos(\omega t)$$

$$i_3(t) = \left(C_{31} - \frac{C_{32}C_{21}}{C_{22}} \right) \frac{du_1(t)}{dt} = \omega U_1 \left(C_{31} - \frac{C_{32}C_{21}}{C_{22}} \right) \cos(\omega t)$$

Problem 6.7.4

A section of a three-phase symmetrical shielded cable is described by its capacitance matrix

$$[C] = \begin{bmatrix} C_s & -C_m & -C_m \\ -C_m & C_s & -C_m \\ -C_m & -C_m & C_s \end{bmatrix}$$

As shown in Figure 6.9, the internal cable conductors are all short-circuited. The cable is left open at its far end. At the near end, a ramp-type voltage is applied between the reunion point of the conductors and the shield conductor.

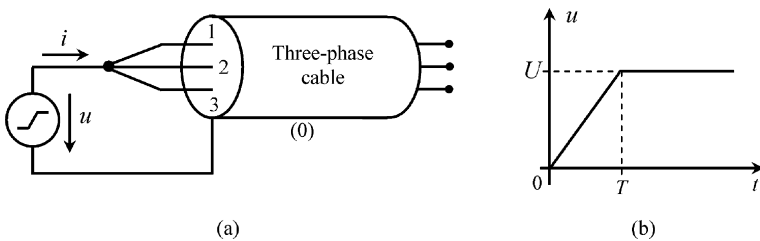

Figure 6.9 Shielded three-phase cable. (a) System connections. (b) Generator voltage

Data: $C_s = 50 \text{ nF}$, $C_m = 20 \text{ nF}$, $U = 5 \text{ kV}$, $T = 1 \text{ ms}$.

- Q₁ Write the equations governing the system.
- Q₂ Determine the generator current $i(t)$, showing that it has the shape of a positive pulse.
- Q₃ Evaluate the energy expended by the generator to charge the cable. Compare it to the final electric energy stored in the cable.

Answers

Q₁ From (6.11) with $u_1 = u_2 = u_3 = u(t)$ you find

$$i_1(t) = i_2(t) = i_3(t) = (C_s - 2C_m) \frac{du(t)}{dt}$$

$$i(t) = i_1(t) + i_2(t) + i_3(t) = \underbrace{3(C_s - 2C_m)}_C \frac{du(t)}{dt}$$

where C is the equivalent capacitance observed at the generator terminals.

Q₂ Since $C = 30 \text{ nF}$ and $du/dt = 5 \text{ MV/s}$, you find

$$\begin{cases} i(t) = I = 0.15 \text{ A,} & \text{for } 0 < t < T \\ i(t) = 0, & \text{for } t > T \end{cases}$$

Q₃

$$W_G = \int_{t=0}^{t=\infty} ui \, dt = \int_{t=0}^{t=T} ui \, dt = \frac{UIT}{2} = 375 \text{ mJ}; \quad W_e = \frac{1}{2} CU^2 = 375 \text{ mJ for } t > T$$
