

7

Electric Motors

Joris Lemmens and Wim Deprez

The energy efficiency of electric motor systems has strongly gained in importance and interest over the last decade. The underlying reason for this evolution can be found in the context of the challenges the energy sector is facing. A fundamental issue is the increasing consumption of energy coupled with the forecasted growth in the global economy. Unsustainable pressure on natural resources and the environment is inevitable if energy demand is not (at least partly) decoupled from economic growth. A global revolution concerning energy supply and use is needed. Amongst several technologies and scenarios, a far greater efficiency of 'Energy using Products' (EuPs) is a core requirement to reduce global energy consumption. It should be understood that increasing electric motor efficiency must be considered as part of this top category of measures.

Electric motor systems in general are widespread in industry, the service sector and buildings. In terms of energy consumption, electric motor systems account for roughly 40% of the total electricity demand of today. Approximately 65% of the electricity that is used in industry is consumed by electric motors [1], the majority (more than 96%) of the industrial motors being AC motors of which approximately 90% are induction machines (IM). For the enlarged European Union (EU-27), in the year 2006 the total electricity consumption was 3268 TWh, in industry 1143 TWh and for industrial motor systems in particular 742 TWh [2]. By 2020, the industrial electricity consumption in the EU-27 is estimated to approach 1432 TWh and the consumption of industrial electric motors 859 TWh if no action is taken. However, if the EU attains all the feasible energy savings in those motor systems (estimated at 31%), the result would be an annual saving of 270 TWh, equivalent to the total electricity consumption of Spain in 2000 [1]. Note that the total electricity consumption and potential savings of motor systems are even higher as motor systems in the service sector and in buildings should also be taken into account.

The European (EU-15) low voltage AC motor market in 2006 was estimated at 9 million units. In common applications such as heating and cooling facilities, elevators, escalators and transportation, induction motors are mostly used because they are robust, maintenance free,

versatile and efficient and can be produced cost-effectively. This is why IMs are often called ‘the workhorse of industry’ and, since the introduction of variable speed drives (frequency converters or VSDs), even ‘the race horse of industry’. In the last decades, most attention and effort concerning energy efficiency (technology and standardization) focused on IMs. However, the changing boundary conditions, i.e. environmental concern, increasing energy costs, material costs, mandatory minimum efficiency requirements, etc., mean that other motor types and technologies become an increasingly interesting alternative. It is expected that for low power and/or specific applications other motor types, for example permanent magnet synchronous motors (PMSM), are necessary to reach the highest requirements [3].

In this chapter on electric motor efficiency, it is not the intention to present an in-depth technical overview of state of the art motor technology but rather to identify the main points of attention concerning motor system efficiency. It is important to understand that electric motors transform electric energy rather than consume it. Most of the electric input power is converted into mechanical (shaft) power with inevitably, a certain amount of motor (and converter) losses that depend on the applied motor technology, materials, design, environmental conditions, etc. Investments in more energy-efficient drives to reduce these losses are led by economic/ecologic considerations and legislation. Electric motors belong to the so-called ‘Energy using Products’ or EuPs. The purchase and maintenance cost is only a fraction of the lifetime energy cost, especially for continuous duty applications. As an example, consider a 7.5 kW IM in full load, continuous duty operation with an efficiency of 89%, an expected lifetime of 25000 hours, a purchase cost of 70 €/kW and an energy cost of 10 c€/kWh. The purchase cost is only €525 and the energy cost €21 067, 2.5% and 97.5% respectively of the total cost. Keeping in mind the ever-increasing energy prices and the large amount of energy used in motor systems, investments and technological advances in more efficient electric drives are necessary from an economic and ecologic point of view.

This brief introduction should indicate the different points for attention in motor driven system efficiency and, consequently, the items addressed in the next sections of the chapter. There are two distinct aspects concerning energy efficiency of motor systems. On the one hand, there is the technological side concerning motor, converter and mechanical losses. On the other, there is the aspect of policy, legislation and standardization. The latter is required to enable and secure the market of efficient electric drives and also to ensure the implementation of high efficiency motors (HEMs) in products of, for instance, OEMs (Original Equipment Manufacturers).

The first section of this chapter focuses on the losses in electric motors. First the different loss components are described. Next, the influence of practical operating conditions on efficiency is addressed. The second section is devoted to standards on efficiency testing and classification. In the last section, the technology used in high efficiency motors is briefly discussed by looking at materials, design and manufacturing evolutions.

7.1 Losses in Electric Motors

In order to understand the meaning of energy efficiency and the improvement potential in electric motors and drives, a basic understanding of the loss components is required. There are numerous types of electric motors (Figure 7.1), but in industrial applications, the squirrel cage induction motor is the most common, as already stated in the introduction. Consequently,

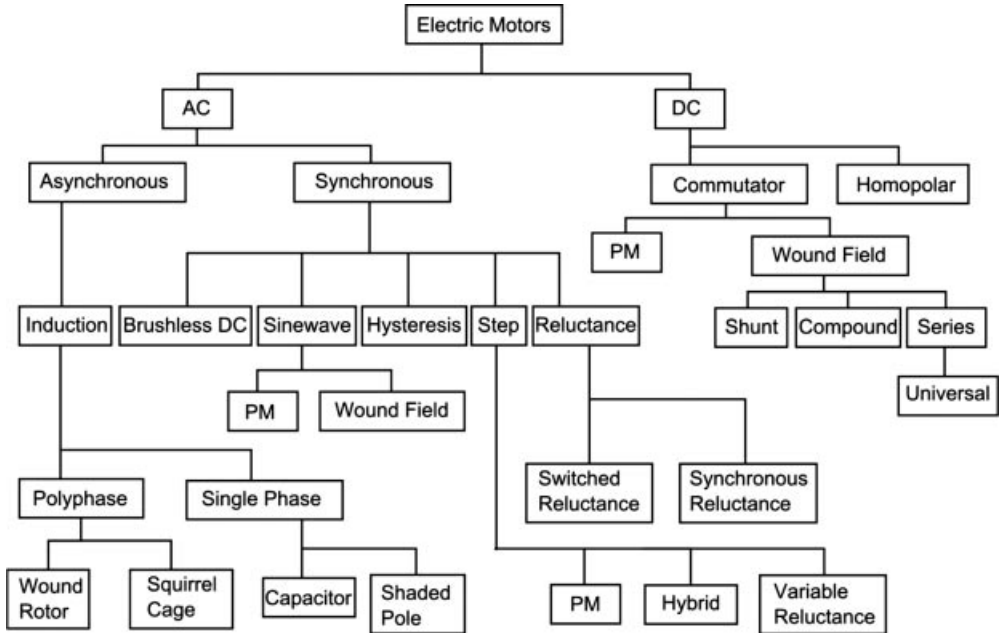

Figure 7.1 Classification of electric motors according to operating principle

the discussion about motor efficiency and losses over the last decades was mainly focused on IMs. Most of the IM loss components generally return in the other motor types, of course in a different order of magnitude and mutual distribution. Therefore, the treatment of losses in this chapter is confined to the IM.

7.1.1 Power Balance and Energy Efficiency

The losses in an IM consist of joule losses in the stator windings P_s and the rotor cage P_r , iron losses P_{FE} due to hysteresis effects and eddy currents in the laminated steel core, mechanical losses $P_{fr,w}$ due to friction in the bearings and windage losses of the cooling fan and additional or stray load losses P_{SLL} , which represent a number of losses not categorized under the previous items.

In Figure 7.2, the power balance or Sankey diagram for an IM in motor mode is shown, the thickness of the individual loss arrows is proportional to the specific power value concerned.

Theoretically, the determination of the efficiency for motor or generator mode is quite straightforward. It is the ratio between output mechanical power P_{mech} and input electric power P_{el} , usually expressed as a percentage (7.1). From the Sankey diagram, clearly the difference between the input and output power flow consists of the losses P_{loss} so the efficiency can also be expressed as a function of electric power and losses:

$$\eta_M = \frac{P_{mech}}{P_{el}} = 1 - \frac{P_{loss}}{P_{el}} \tag{7.1}$$

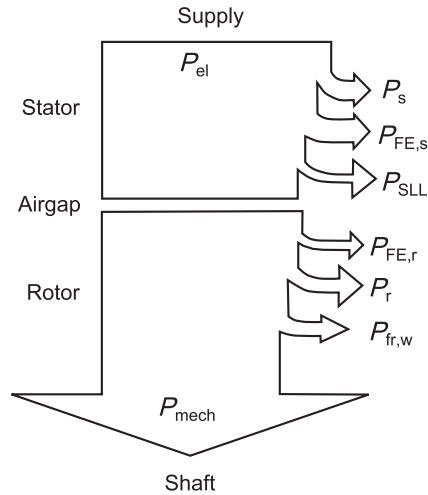

Figure 7.2 Power balance or Sankey diagram of an induction motor

Based on equation (7.1), the testing methods to determine efficiency can be categorized as either direct or indirect. For the direct method, the electrical and mechanical powers have to be measured. This necessitates an accurate power analyser, speed and torque measurement device. For accurate torque measurements, the range of the torque transducer should be adapted to the rated torque of the motor. Additionally, efficiency values obtained by this method depend on ambient and motor temperature, which is not desirable for a transparent and reproducible efficiency rating. Motor efficiency values obtained for different (ambient) temperature conditions cannot be compared using this approach. Moreover, it can be proven that the accuracy of this direct method is low, even when very precise equipment is used.

The other approach, the indirect method, is based on the separate determination of the individual loss components, the so-called ‘segregation of losses’. It is applicable to several DOL (Direct On Line – thus for motors that are directly connected to the grid) motor types, but is mostly used for induction machines. With a load and zero-load test, it is possible to identify precisely the conventional losses, including stator and rotor joule loss, iron loss, and friction and windage loss. However, as early as 1912, it was shown that there exists a reasonable difference between the total conventional losses determined from the loss segregation method and the total losses found from a direct load test. This difference is covered by a loss component that is not included in the conventional losses. This additional power loss component, termed stray load loss, is caused by a number of parasitic effects due to the non-ideal nature of a practical machine (see further). It is impossible to measure this loss component directly, but there are several possibilities to account for them. The chosen approach for the determination of stray load losses is the most important difference between standards for efficiency measurement of IMs. The advantages of indirect over direct methods are mainly that the overall accuracy is higher and that they allow the correction of the different loss components to a specified ambient and reference motor temperature, and reduce measurement errors.

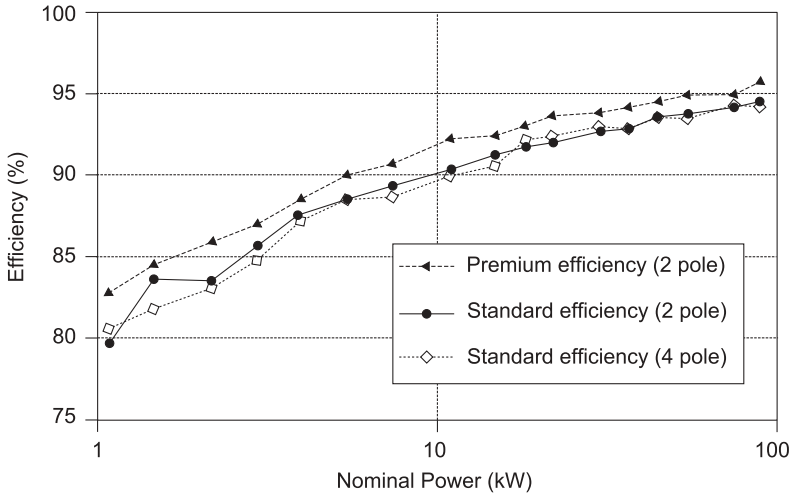

Figure 7.3 Rated load efficiency of cast iron frame induction motors for a two- and four-pole standard efficiency motor and a two-pole premium efficiency motor based on manufacturer data

7.1.2 Loss Components Classification

According to scaling laws, efficiency rises with increasing volume of active parts (core and conductors), thus frame size or power rating. This can be illustrated by plotting the rated efficiency versus power rating for a series of motors (Figure 7.3).

Figure 7.4 indicates the mutual distribution of loss components according to the rated motor power. The relative proportions of iron and rotor losses are almost independent of the frame size. On average, they each amount to about 20% of the overall losses. The introduction of high efficient IM designs with, for example, a copper rotor changes this general picture very much. This is due to the interrelations between these loss components as elucidated more in detail later on. For motors of lower power ratings, the ohmic losses in the stator windings are dominant. They amount to approximately 50% of the overall losses, whereas for large machines they are reduced to about 25%. The additional or stray load losses rise from a very low relative contribution to well above 10% for the MW range motors. A more or less similar contribution can be recorded for the part of the friction and windage losses.

From the nomenclature of the losses it is obvious that they all have their specific location within the IM. Such a classification results in only three possible areas: the windings (stator and rotor), the magnetic circuit (stator and rotor iron) and the bearings and air-gap (mechanical losses). The stray load losses are also located in one or more parts of the stator and/or rotor.

A classification of the electromagnetic losses, consisting only of winding and core losses, subdivides these loss components into fundamental, space harmonic and time harmonic losses. In general, time harmonic components have very little importance in constant speed (mains) applications when supposing good power quality. However, they do have to be considered when the IM is supplied from power electronic converters. The spatial harmonics of the stator and rotor MMF are related to practical (constructional) limitations, such as slotting, magnetic saturation and eccentricity. All harmonic components give rise to additional losses in stator and rotor core and windings.

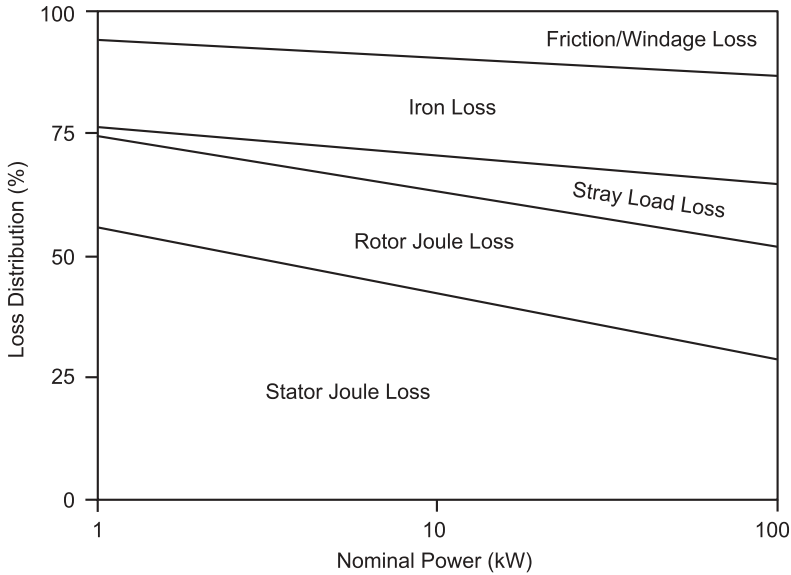

Figure 7.4 Distribution of loss components according to the rated power of the induction motor

Another possible classification is used as a basis for the loss segregation in several efficiency standards. This approach classifies the losses into two parts: constant and load dependent. Loss components assumed to be constant, are friction, windage and iron losses. The calculation of these losses based on motor geometry and material data is not trivial, especially the calculation of the iron losses. Steinmetz derived an expression (7.2) to approximate core losses:

$$P_{\text{core}} = P_{\text{hyst}} + P_{\text{eddy}} = k_{\text{hyst}} f B^n + k_{\text{eddy}} f^2 B^2 \quad (7.2)$$

where P_{core} is the core loss, P_{hyst} is the hysteresis loss, P_{eddy} is the eddy-current loss, f is the frequency of the sinusoidal magnetic field, B is the flux density and k_{hyst} , k_{eddy} and n are coefficients that depend on the lamination material, thickness, conductivity and other (geometry) factors. It can be used in analytic or FEM (finite-element modelling) approaches, but even in the case of the latter, the main problems with core loss determination still exist: the flux density is constantly changing in magnitude (up to local saturation) and/or direction and has harmonic components. Moreover, the degradation of magnetic properties due to mechanical manufacturing is not constant and is difficult to take into account in a model.

To determine these constant losses from tests, the so-called practical no-load test is mostly used. More about this test and the decomposition into the different components is discussed in Section 7.2.2, dealing with the different standards. It must be noted that the effect of slotting is also present at no-load, as in this mode space harmonics are present. Therefore, the iron losses in fact include additional losses, termed no-load stray losses.

The load dependent losses are the copper losses in stator windings (P_s), in rotor conductors (P_r) and stray load losses (P_{SLL}). The stator copper losses are calculated from the current corresponding to the load point considered and from the winding resistance. The winding resistance is measured, and corrected for a specified reference temperature according to the standard used.

The joule losses in the rotor conductors are also proportional to the load current of the machine. In a practical steady-state no-load situation, the actual speed is very close to the synchronous one. The rotor slip, being very small, gives rise to a torque to cover mechanical losses. The corresponding rotor current and frequency and their resulting rotor copper and core losses are very small. In fact, they are covered by the constant losses. When the machine is loaded, the slip increases in order to balance the load torque. The resulting rotor currents now start to produce increasing joule losses in the rotor. As the rotor frequency remains fairly low in the entire operating range of an IM, all the load dependent rotor losses can be considered as being joule losses. The rotor losses can be determined as the slip fraction of the air-gap power. For these losses also different correction methods according to standards, apply.

The stray load losses at least that part of harmonic losses not covered by the (considered as constant) iron losses, are the last, but most notorious load-dependent losses. They can be linked to three practical machine restrictions:

- Magnetic property limitations of electrical steel in the motor core, which leads to local saturation;
- The fact that a practical geometry is used, with slots and a discrete instead of perfectly sinusoidal winding giving rise to space harmonics and leakage flux;
- Industrial imperfections due to manufacturing, for example, the cross-bar currents that can occur due to the imperfect insulation of rotor cage bars.

They consist of supplementary losses occurring at load in the core and other metal pieces of the machine and eddy-current losses in both stator and rotor conductors caused by current depending leakage fields. They result in additional heating of the motor and a reduction in motor torque. These losses have been the subject of many research projects and publications investigating their origin, consequences, determination and simulation. A comprehensive overview of the origin, components, measurement methods and effects of additional losses can be found in several publications [4, 5].

7.1.3 Influence Factors

IMs, or other motor types, are only one of the components of an electric motor application. The overall system efficiency depends on several factors such as motor efficiency, temperature and sizing, motor control, mechanical transmission, maintenance practices, mechanical efficiency, losses in the supply system, supply quality, etc. Therefore, a short overview of the important factors influencing the system efficiency is given. It is almost impossible to give an exhaustive overview of points of interest as each application has particular requirements and boundary conditions. However, the most common and typical issues are addressed and some examples are given.

On the nameplate of a motor or in catalogues, mostly only the rated value of the efficiency, determined according to a certain standard, is given. This value and even the partial load values are determined based on fixed boundary (e.g. temperature, voltage) conditions. The rated values correspond to a steady-state situation, which means that under normal surrounding conditions, the motor can operate continuously (practically non-stop) at the specified load. In fact, the motor then operates at the thermal equilibrium for which it is designed, and the temperature of the

different motor parts is under control. In practice these conditions are rarely met and as a consequence the resulting motor temperature will deviate from the standard test conditions. And in practice motors are often not operated at rated power, but at a lower power level or exceptionally at a higher. This over-rating (or under-rating) can have several reasons (starting torque, for example). Consequently, the practical efficiency will mostly deviate from the one listed on the nameplate. The most important ‘deviating’ practical motor operating conditions are [6]:

- Load conditions that differ from the rated output;
- Different operating temperatures;
- Unfavourable conditions due to bad maintenance;
- Deviating electrical supply conditions (power quality issues).

7.1.3.1 Temperature Effects

The different loss components are temperature dependent. The winding resistances rise by approximately 4% per 10K of temperature rise, and thus copper losses will increase proportionally. It can be shown that, depending on the motor size, the effect of this dependency on the rated-load efficiency can amount from 0.2 percentage points up to 2 percentage points. Windage losses vary inversely proportionally with temperature. With a relative humidity of 80% and a normal atmospheric pressure, the windage losses in the considered temperature range decrease approximately 4–5% for each 10K of temperature rise. Iron losses decrease with rising temperature, depending on sheet quality and magnetic flux density, they are by 4–8% lower at 100°C than at ambient temperature [6]. From Figure 7.5 it is clear that the temperature conditions affect the practical efficiency value.

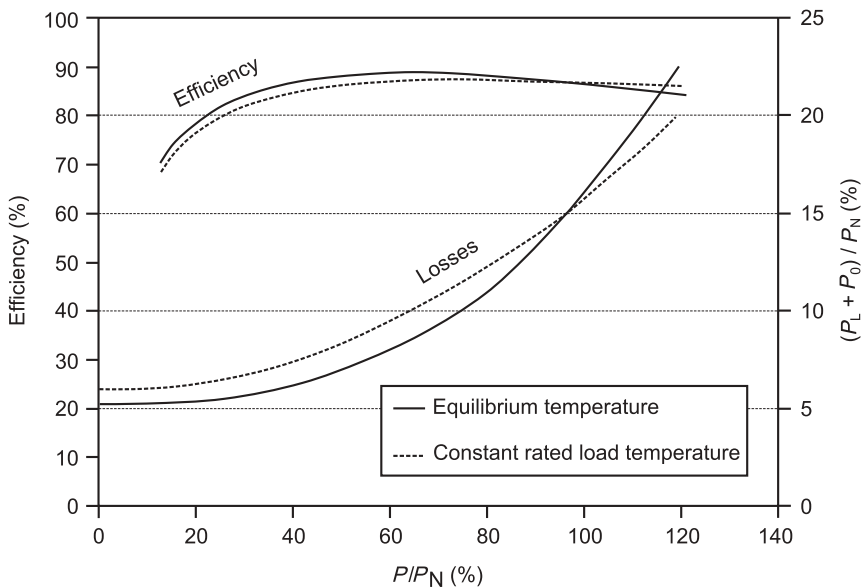

Figure 7.5 Influence of operating temperature on motor efficiency and total specific loss $((P_L + P_0)/P_N)$, P_L is the load dependent part of losses, P_0 are the constant losses, P_N is the rated power [7]

7.1.3.2 Partial Loading

The dotted efficiency characteristic of Figure 7.5 represents a typical efficiency characteristic, i.e. the load dependence of the motor efficiency as recorded according to an efficiency standard. From this figure it is also clear that a practical, continuous duty, partial-load efficiency differs from that determined by the standards, mainly due to temperature effects. There is an approach that can be used to estimate these effects. It is known that the load dependence of the efficiency (at constant reference temperature) can be mathematically defined [8]. This approach splits the losses at rated power (P_N) into a load independent P_0 and a load dependent component P_L . The efficiency can therefore be approximated by (7.3):

$$\eta_{(p)} = \frac{1}{1 + \frac{v_0}{p} + v_L \cdot p} \quad (7.3)$$

with $p = \frac{P}{P_N}$, $v_L = \frac{P_L}{P_N}$ and $v_0 = \frac{P_0}{P_N}$. From this, it can be found that the maximum efficiency (7.4) is located at the load point $p^* = \sqrt{v_0/v_L}$; this is the point for which the load dependent losses become equal to the constant losses:

$$\eta^* = \frac{1}{1 + 2 \frac{\sqrt{P_0 P_L}}{P_N}}, \quad (7.4)$$

7.1.3.3 Maintenance

With these mechanisms in mind, it is possible to deduce some aspects and influences that bad maintenance practices may have on (induction) motors. For instance, when the system is operated in an environment involving a lot of dirt, process spills or other waste, it is important to clean the motor and especially its cooling fins and the cooling fan inlet. If this is not done regularly or properly, this may prove to be detrimental to cooling performance with increased overall losses and a decreased efficiency as a consequence. It is already noted that even if decreased efficiency would not be an issue, the higher temperature at thermal equilibrium of such cases can lead to early failure of the machine. Another example concerns the maintenance of bearings. If bearings are not greased/replaced in time, they cause higher friction losses.

7.1.3.4 Deviating Supply Conditions

Electrical supply conditions can have a significant influence on motor losses and efficiency. Many individual aspects concerning this issue are described in publications [9]. There are also separate standards in which even typical values for the distinct influences are given. For instance, IEC 60038 and EN 60150 are concerned with supply quality, EN 61000-2-4 for EMC noise immunity, IEC 60034-28 for voltage unbalance and according derating and EN 60204-1 for requirements on the electrical equipment of machines. In particular, because of the sensitivity of squirrel-cage IMs to voltage unbalance and/or harmonics, the latter describes the effects and include data on how they influence thermal conditions. These altered thermal conditions mostly lead to increased winding temperature and therefore, also the extent to which the continuous output power should be reduced in order to protect the winding insulation (i.e. derating), is stipulated.

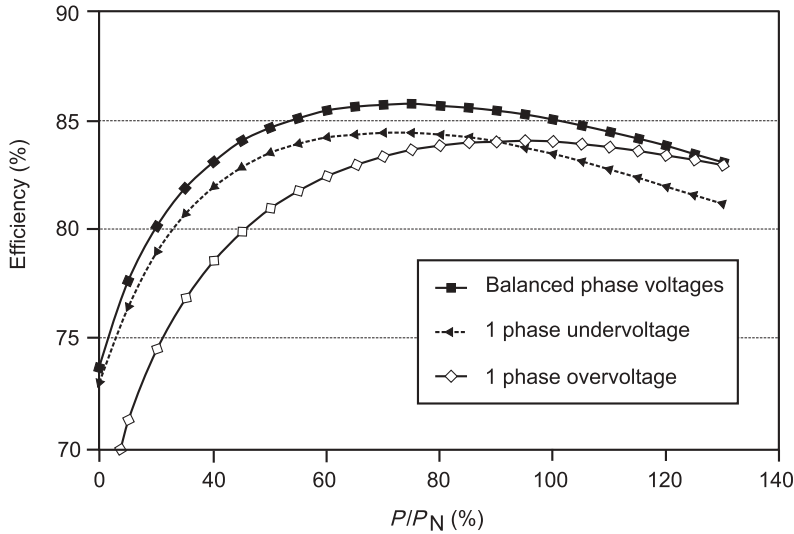

Figure 7.6 Efficiency characteristic according to IEEE112-B for a standard general purpose 7.5 kW induction motor. The unbalanced cases represent a voltage unbalance factor (VUF) of 4% by a one phase over or under voltage

As an example, Figure 7.6 gives the efficiency characteristics of an IM for the standard test conditions and for unbalanced voltage conditions. In a three-phase system, a voltage unbalance is the phenomenon in which the rms values of the (fundamental) voltages or the phase angles between consecutive phases are not equal. When an IM is fed by unbalanced voltages, an additional breaking torque is created, resulting in extra losses and possibly in motor failure [6]. Next to the lower motor efficiency when subjected to unbalanced supply conditions, the figure also shows a shifted efficiency curve with a maximum at higher or lower power compared with the balanced supply according to the present unbalance.

7.1.3.5 Converter Operation, Power Quality and Supply System

As has already been indicated above, harmonics cause additional motor losses. Several publications that are based on simulations and experiments are devoted to this subject. They indicate increased losses due to the harmonics associated with the use of frequency converters, but also increased noise and losses in variable speed induction motor drives with (IGBT) inverters, voltage reflections and associated grounding issues and even bearing damage [10–12].

The losses in the supply system components such as cables and transformers are also known as ‘distribution losses’. These losses cannot be neglected as overloaded components may lead to increased losses. Moreover, these system components should be designed allowing for the deviating power factor in partial load conditions.

7.1.3.6 Mechanical Transmission

Some applications require a mechanical transmission. There are several possible solutions for such a transmission, i.e. gearboxes, V-belts, toothed-belts, cogwheels (helical or bevel gears),

worm wheels, etc. Generally, belts have a high efficiency, i.e. 90% for V-belts to 97% for toothed V-belts. With cogged wheels an efficiency of 98% may be possible. The efficiency can also be a function of the loading of the gear. Worm wheels have very low and highly load-dependent efficiency.

7.2 Motor Efficiency Standards

7.2.1 Efficiency Classification Standards

The efficiency of motor-driven systems is of major importance, especially in the case of induction motors constituting the bulk energy use in industry. Even a modest increase in motor efficiency will yield considerable benefits in environmental, economic and strategic terms. Governments, with a responsibility to inform and to regulate, have been increasingly proactive in matters regarding device efficiency. There are numerous examples of national and international agreements, incentives and initiatives worldwide. For Europe, this is reflected in different ongoing programmes: ‘The European Motor Challenge Program’, the former classification scheme of industrial AC motors with the EFF1, EFF2, EFF3 labels of CEMEP (European Committee of Manufacturers of Electrical Machines and Power Electronics) voluntary agreement, the ‘4E Electric Motor Systems Annex’ initiative and finally the new IEC 60034-30 IE-classification standard. This standard is the result of several initiatives and pleas to harmonize the different motor classifications and in fact efficiency standards worldwide. Figure 7.7 and Table 7.1 give a representation of these IE efficiency classes compared with the American and former European classifications. This IE-classification merges the main aspects

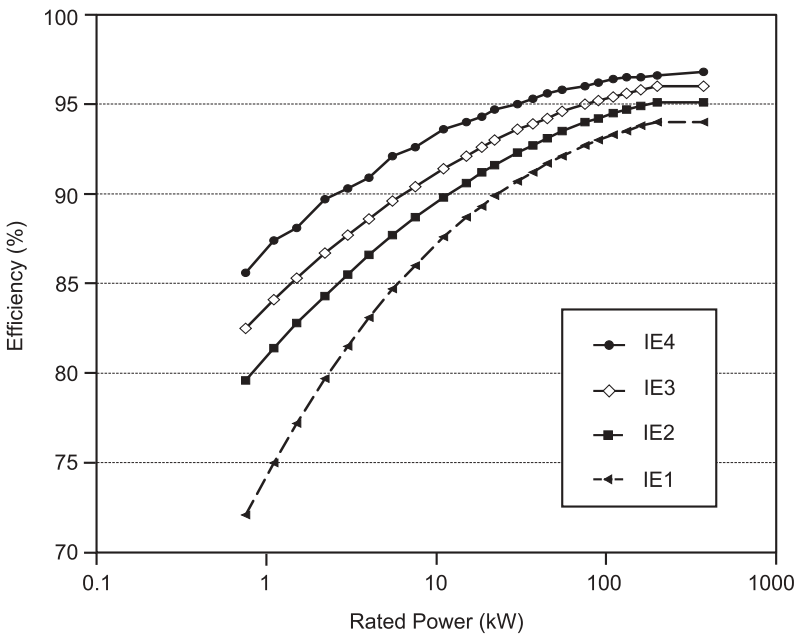

Figure 7.7 Representation of the new IE efficiency classes (four poles) defined in IEC Std 60034-30

Table 7.1 Harmonization of European and American classification by IEC 60034-30

Efficiency	IEC 60034-30	Europe (CEMEP)	United States
Super premium	IE4		
Premium	IE3		NEMA Premium
High	IE2	EFF1	Epact
Standard	IE1	EFF2	

of the American NEMA Premium/Epact and European CEMEP classes and therefore it is now valid for 50 as well as 60 Hz machines of 2, 4 and 6 poles. It is a worldwide, voluntary standard for AC motors between 0.75 and 375 kW. There are four classes (IE1 to IE4), leaving room for future classes. The IE4 class will also be valid for rated and partial load conditions of inverter fed motors such as PMSMs. In particular, this last feature is a progressive measure that may enhance the correct promotion of energy efficient drives.

This new standard IEC 60034-30 deals with the variety of different efficiency classes worldwide, whether voluntary or mandatory, which is a positive step. However, past experiences with these different approaches have taught us one thing: mandatory MEPS positively influence the penetration of the superseding efficiency level (settled by a voluntary measure). Therefore, the European Commission translated this new IEC classification into a Directive (Dir. 2009/125/EG) in 2009.

The application range of this Directive is more limited compared to the IEC classification, but it introduces the mandatory aspect of minimum efficiency performance standards (MEPS) in Europe. It applies for three-phase, single-speed, continuous-duty squirrel cage motors of 2, 4 or 6 poles operated at 50 or 60 Hz, up to 1000 V and with rated power between 0.75 and 375 kW. The most important exceptions with regard to the IEC Standard 60034-30 are submersed motors, applications for which motor and application cannot be treated separately, braking motors and motors specifically designed for exceptional (altitude or temperature) conditions. The Directive foresees three phases during which the mandatory MEPS should be introduced and applied:

- 16/06/2011: 0.75–375 kW minimum IE2 and thus the end of EFF2/IE1;
- 01/01/2015: 7.5–375 kW minimum IE3 or IE2 in VSD-application, thus the end of EFF1/IE2 for DOL applications;
- 01/01/2017: same for small motors 0.75–7.5 kW.

The efficiency test standard to be applied is IEC Std. 60034-2-1. This revised edition (2007) of the IEC measurement standard for AC motors excluding traction motors is now harmonized with other important standards (IEEE). But, as will be explained below; this is not enough yet as several methods of determining the efficiency are still allowed by this standard, leading to ambiguity.

7.2.2 Efficiency Measurement Standards

Evidently efficiency classifications assume that efficiency measurement methods are established well beyond reproach and agreed upon in national and international standards. However,

as with the efficiency classification standards, different efficiency measurement standards are used worldwide. A closer examination of standards reveals that there are major discrepancies between methods proposed by them [13–16], causing differences in the resulting efficiency values. This has serious consequences both in terms of issuing certificates and credibility of the declared efficiency values for decision making when purchasing motors. Motor system components are ‘world widely’ traded commodity goods. As they are subject to different local or national testing standards and performance and labelling requirements, large variations in the market penetration of high efficiency motors around the globe can be found.

Based on the criticism in several publications, questions from parties involved and other initiatives, the IEC started a process to update the controversial version of their motor efficiency standard. After a long process, the new version of the IEC Standard 60034-2-1 was published in September 2007. The method most used for efficiency determination described by this new standard is now aligned with the other important standard in this field, IEEE Standard 112-B. However, an additional method (EH-Y) for determining stray load losses is given. Given the numerous ‘sub-methods’ allowed by the respective standardization organizations, it cannot be stated that the standards for efficiency determination of (induction) motors are clear, unambiguous or harmonized. It should be noted however, that this standard is currently under revision again and, most likely, this contested method (EH-Y), will be removed.

Additionally, as described previously, the prescribed methods do not account for non-ideal operating conditions of a real application as opposed to the ideal test conditions described in the standard. For instance, standards are conspicuously silent on matters pertaining to unbalanced supply or poor power quality. Also, the practice of certifying efficiency on the basis of a single rated load efficiency value can be questioned.

7.2.2.1 General Procedure and Test Setup

In Section 7.1.1, two expressions (equation (7.1)) for the efficiency of IMs were introduced (direct and indirect) and the different loss components were indicated and discussed. The difference between the direct and indirect efficiency determination is introduced. The direct method is indicated as less accurate as it directly applies the measured mechanical and electric power. The most important standards are all based on the indirect method, based on the segregation or summation of losses. As already indicated, five loss components have to be determined using an indirect method: stator joule losses (P_s), rotor joule losses (P_r), iron losses (P_{FE}), friction and windage losses ($P_{fr,w}$) – these four components are mostly indicated as conventional losses P_{conv} – and the additional or stray load losses (P_{SLL}). These ‘additional’ losses can be estimated as the difference between the total measured losses (the difference between electric input power and mechanical output power) and the conventional losses.

The main difference between standards consists of the method to determine the stray load losses. The previously mentioned method to account for P_{SLL} is often termed the indirect ‘Input–Output’ method. Several publications indicate this method as most appropriate for an accurate determination of the stray load losses and IM efficiency [17–19]. Note that this method requires an accurate measurement of torque and speed, but it does not directly apply the measured mechanical power to obtain efficiency.

A second indirect method prescribed by some standards is based on a so-called fixed or variable allowance to estimate the stray load losses. In such methods, the mechanical power

is not measured (no torque measurement needed) and the stray load losses are arbitrarily estimated to be equal to a certain percentage – the allowance – of the full-load input power (Table 7.4).

A third method recently included in the new version of the IEC60034-2-1 standard is the Eh-star (Eh-Y) method. In this method the stray load losses are determined from a separate test during which the IM is operated in no-load on a special (asymmetric) single-phase connection with an auxiliary resistance (R_{ch}). This method is very controversial, and most probably will be removed in a next revision of this standard.

It should be clear that the stray load loss estimation is the major difference between standards. Clearly, as there are several methods to determine the stray load losses, the outcome of an efficiency measurement depends mainly on the standard used. Nevertheless, the general measurement procedure and thus the number of required tests for each of the different standards are fairly similar. The general procedure and the test bench required for the determination of the five loss components and the efficiency are described now.

Figure 7.8 shows the schematic of a test setup that can be used for testing motors in VSD or DOL application. It is a facility with the capability of mechanically loading the motor and drive at the different operating points (torque and also speed in VSD application) as determined by the test protocol. To establish this loading, a controlled AC or DC drive may be used. The setup is also equipped with a torque and speed measurement device. A digital power analyser is used for the electrical measurements, i.e. voltage, current, frequency and power, which are

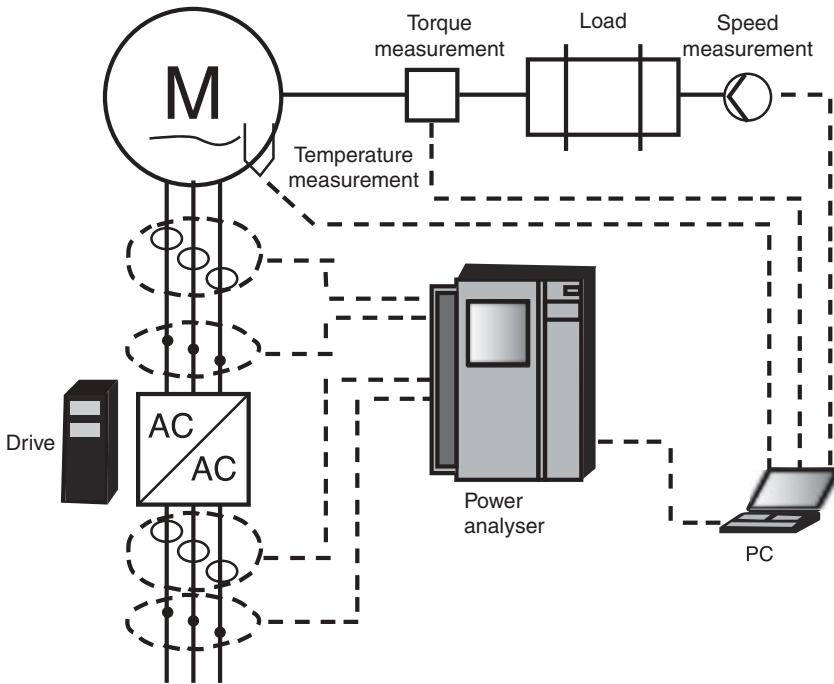

Figure 7.8 Schematic of the test setup that can be used for efficiency measurement of VSDs as well as for DOL motors; in the latter case the drive is by-passed

measured before and after the power electronic converter. This allows one to determine the motor and inverter efficiency separately. The measurements are controlled in such a way that they are recorded simultaneously. The accuracy of the electrical quantities at the fundamental frequency and the torque have a certified accuracy of $\pm 0.2\%$. The range of the torque transducer should be adapted to the motor power and the accuracy of the speed measurement is ± 1 rpm. The test setup should also be equipped with a temperature measurement device to keep track of the motor temperature. This temperature sensor should be located as near to the stator winding as possible, preferably in a slot or on the end-windings. As a more convenient alternative, the temperature sensor can also be mounted on the motor frame.

However, for VSD testing, given their nature, harmonics at the input and output of the converter are involved and should be considered when selecting and programming the measurement equipment. Therefore, the frequency range of the digital power analyser should be several kHz, preferably 200–300 kHz.

In general, an efficiency measurement procedure consists of three types of tests: (ambient) temperature and winding resistance determination, a load test (with or without torque measurement) in which a number of load torques are applied to the motor, and a no-load test in which the stator voltage is decreased gradually. Except for the method where the stray load loss determination is based on the Eh-Y procedure, all major standards prescribe a similar procedure for these three types of tests. For the Eh-Y test, an additional test is required.

From the no-load test, the iron and friction and windage losses – the no-load losses – can be determined separately. The stator joule losses are determined from the stator current measured in each point of the load test and the stator resistance value. Depending on the standard used, the losses are corrected to a reference ambient temperature based on winding resistance corrections. Next, the rotor joule losses can be calculated as the slip fraction of the air-gap power, which can be found by subtracting the iron and stator joule losses from the electrical input power.

Note that, for some standards, there is also a (temperature dependent) slip correction influencing the rotor joule loss to account for temperature deviations during the test. Consequently, if the stray load losses are determined according to ‘input–output’ method, they are also influenced by this correction. The different standards and methods each determine a specific procedure for the different phases of the measurements and also (temperature) corrections to be applied when processing the measurement results to achieve final efficiency values. Besides the different approach in determining the stray load losses, differences in these procedures and corrections ensure that these standards are not unambiguous.

7.2.2.2 Differences between Measurement Standards

As outlined above, and also underlined in several publications, the main difference between most efficiency determination methods for induction motors is to be found in the determination of the stray load losses. The value obtained for the efficiency of an induction machine depends on the method and standard used. Such differences can amount to up to several percentage points in the efficiency (Figure 7.9). In general, the differences between standards are not only at this technical level of determination of additional losses. There are other dissimilarities or peculiarities that can be distinguished. Some examples of these differences are in terminology, scope, titles, required instrumentation, accuracy, (number of) proposed methods, etc. In

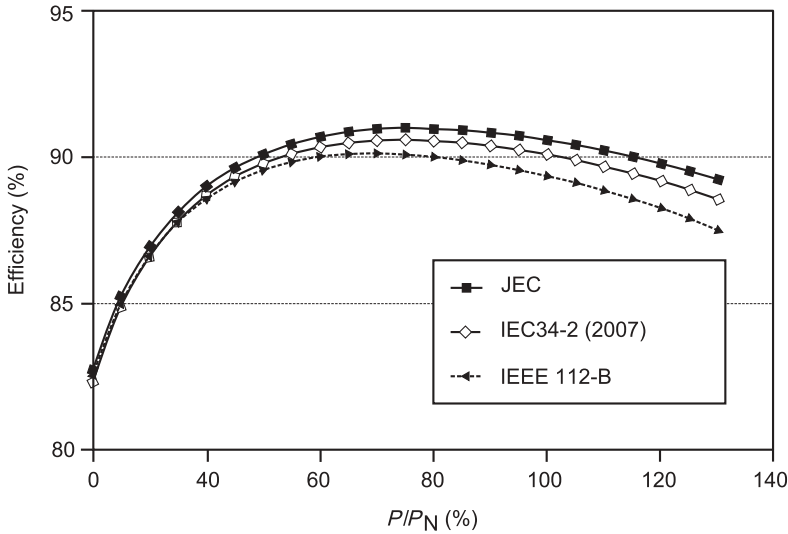

Figure 7.9 Efficiency of a four-pole 7.5 kW induction motor, measured according to three different standards. This results in efficiency differences of up to several percent

particular, the last two examples have a specific impact on the final result of the efficiency determination. Care should be taken when comparing or discussing different methods and their results, since the accuracy of this outcome should also be taken into account.

The two most important standards for the determination of induction machine efficiency are IEC Standard 60034-2 and the IEEE Standard 112. The IEC 60034-2 dates from 1972, but had updates/amendments in 1995 and 1996. The IEC 61972, deals only with squirrel cage induction motors, whereas the IEC60034-2 is for rotating machines in general, excluding traction motors; it was developed as a possible replacement of the IEC 60034-2 version of 1996, but was neither confirmed nor published. The version of IEC 61972 considered here, is the (first) edition of November 2002. Instead of this failed version, the IEC published a new version in September 2007, numbered IEC 60034-2-1. It is important to know that these standards offer different methods to determine efficiency. This is the same with the IEEE 112, divided in about eleven methods, named A, B, B1, C, . . . of which B is the most important and best known method. The IEEE Standard 112 was introduced in 1964 and the latest revisions were made in 1996 and 2004, with only minor changes in the latest version. An overview of standards worldwide is given in Table 7.2.

In spite of this diversity of methods offered by the different standards, most manufacturers, test labs and others only use one or a few methods. The most significant methods are indicated in Table 7.3. For the IEEE 112 the most important method is method B, an Input–Output method requiring the measurement of mechanical torque and speed. The most commonly used method of the IEC 60034-2 (1996) is an indirect method: not requiring one to measure the mechanical torque. The stray load losses in this method are determined based on a fixed allowance (5% of the input power). In fact, there are four important methods: Input–Output, fixed allowance, variable allowance (Table 7.4) and Eh-Y. These differences in approach to determining the stray load losses cause the efficiency results to differ.

Table 7.2 Overview of methods for efficiency determination of induction motors according to recent (versions of) standards

	Status	Year	Significant methods	Remarks
IEEE 112	Valid	2004	Method B	Input–Output method, requiring mechanical torque and speed measurement. It provides several other methods.
IEC 60034-2 Ed. 3	Outdated	1996	Fixed allowance for P_{SLL}	Indirect method. Mechanical torque is not required. It provides some other methods, such as the reverse rotation test (RRT).
IEC 61972	Failed	2002	2	Developed as possible replacement of the 34-2, provides two (main) methods: <ul style="list-style-type: none"> • Input–Output similar to 112B • Indirect w/ variable allowance.
IEC 60034-2 Ed. 4	Valid	2007	3	Recently published, in fact a compromise. Holds the same methods as the IEC 61972 with an additional (new) Eh-Y test to determine P_{SLL} , but, e.g., still holds the RRT.
CSA C390-98	Valid	2005	1	Canadian standard. Very similar to IEEE112B, is used in the context of local minimum efficiency performance standards.
AS 1359.102	Valid	1997	3	Australian standard. Provides the choice between three methods: an indirect method similar to IEC 60034-2 Amd. 2 (1996), a calorimetric method (very accurate but time consuming and expensive) and an Input–Output method as in IEC 61972. It is expected that it will adopt the new version of the IEC 60034-2 (2007).
JEC-2137-2000	Valid	2000	2	Japanese standard. Originally introduced as JEC-37 on February 23 rd , 1934 and revised several times. On March 27 th , 2000 it was revised again and renamed as JEC-2137. It proposes several methods; e.g. Input–Output method and fixed allowance, . . .
GB/T 1032-2005	Valid	2006	Fixed allowance for P_{SLL}	Chinese standard ‘Test procedures for three-phase induction motors’ issued on September 19 th 2005 and implemented on June 1 st 2006. It is similar to the old IEC 60034-2 (1996), proposing an indirect method using a fixed allowance of 0.5% of the input power for the determination of the stray load losses.

Table 7.3 Overview indicating, for each of the four main indirect methods, if it is included in the efficiency standards, the name of the standardized test method and additional remarks

P_{SLL} method	IEEE 112	IEC 60034-2 (1996)	IEC 60034-2 (2007)	IEC 61972	
Input-Output	Yes Methods B & B1	No	Yes Load test with torque measurement	Yes Method 1	Main differences between IEC versions and the IEEE version: <ul style="list-style-type: none"> • Nomenclature: IEC uses residual and stray load losses \leftrightarrow IEEE uses stray load and corrected stray load losses; • Minimum correlation factor for linear regression analysis indicating the quality and repeatability of the test differs: IEEE specifies 0.9, IEC 0.95.
Fixed allowance	No	Yes	No	No	It is assumed that the total value of the stray load losses at full load is equal to 0.5% of the rated input power ($P_{SLL} = 0.5\% P_{el}$). Observe the difference with the variable allowances.
Variable allowance	Yes Methods E1, F1 and E1/F1	No	Yes Assigned allowance	Yes Method 2	Now the allowance depends on the motor rating (P_N), but the assigned values are different for IEC and IEEE standards, Table 7.4. Moreover, for IEC it is a percentage of P_{el} whereas for IEEE of P_N .
Eh-Y circuit	No	No	Yes	No	

Table 7.4 Assigned allowance for stray load losses according to IEEE 112 and IEC 61972 and IEC 60034-2 (2007)

IEEE		IEC	
P_N [kW]	Allowance [% of P_N]	P_N [kW]	Allowance [% of P_{ei}]
–90	1.8	<1	2.5
91–375	1.5	1–10000	$2.5 - 0.5 \log(P_N)$
376–1850	1.2	>10000	0.5
>1850	0.9		

7.2.3 Future Standard for Variable Speed Drives

Many modern applications require accurate control of speed or torque, which can be facilitated with the use of power electronic converters. Moreover, other motor types such as permanent magnet synchronous motors or switched reluctance motors inherently operated with power electronic converters are increasingly filling up niches in the market. They are even becoming economic alternatives to induction motors in VSDs.

Although IEC is preparing a ‘Guide for the selection and application of energy efficient motors including variable-speed applications’ labelled IEC Std 60034-31, to date, there is no internationally accepted test protocol that allows the determination of drive system efficiency at different load points. However, for proper design, measurement and classification of the energy performance of drive systems, the classic motor efficiency standards cannot be used as they concern direct-on-line application only. Several international initiatives try to fill this lacuna. For instance, the new IE4 efficiency limits are already formulated for an entire torque–speed range. Additionally, IEC is working on a new standard for the determination of efficiency of VSDs, labelled 60034-2-3: ‘Rotating electrical machines: Specific test methods for determining losses and efficiency of converter-fed AC motors’.

There are three main issues concerning the assessment of VSD system efficiency. First, there is the problem of the determination of the efficiency for different load points. Compared with direct-on-line efficiency, there are much more possible operating points (speed, torque combinations) and the method of loss segregation as it is installed in most efficiency determination standards is not readily applicable. Secondly, the nature of VSDs means that there are multiple ‘degrees of freedom’ that influence the system’s efficiency. In fact, there is a mutual influence of motor, converter, control algorithm and parameter settings on the respective losses in motor and converter. For which setup, boundary conditions and settings should the efficiency be determined to allow an objective comparison between different motors and drives? And thirdly, there is not yet any harmonized system for the visualization or classification of the VSD efficiency over the entire operating range. However, in the context of (electrical) drive trains for vehicles a useful concept has already been in use for years, namely the so-called efficiency maps or iso efficiency contours [20]. They are in fact the loci of equal efficiency values plotted as functions of speed and torque on the abscissa and ordinate respectively (Figure 7.10).

In fact, the IEC’s efficiency classification already suggests the similar approach of using efficiency maps for the efficiency limits of IE4 motors if the motors are rated for a certain speed–torque range [21]. However, no specific method for the determination of the system efficiency is yet agreed. It is only mentioned that the direct efficiency should be measured

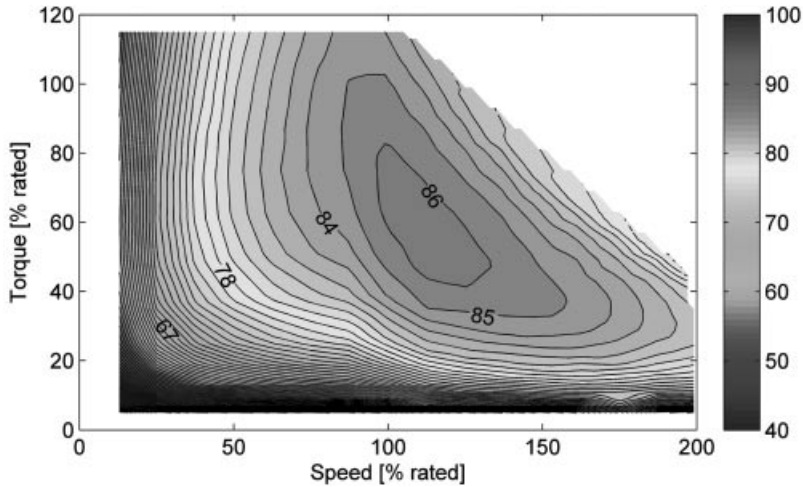

Figure 7.10 Efficiency map of an IE1, 11 kW, 400 V, four-pole induction motor + converter

over the motor's winding connection and the mechanical output (shaft power). Thus this does not take the mutual interaction between motor and converter, or the efficiency of the converter itself into account. Even more importantly, if no extra precautions and conditions are imposed, this will not guarantee an accurate or reproducible efficiency determination. This would be in contrast to the discussions concerning direct-on-line induction motor efficiency determination and the associated motivations for using the segregation of loss method instead of the direct methods. Moreover, in recent publications introducing and promoting the new IEC efficiency classification for IMs and discussing VSD efficiency, a similar approach using a matrix of test points (pairs) for speed and torque is mentioned [22]. There, a suggestion is made to limit the number of testing points according to two common application types: constant torque applications such as conveyors and quadratic torque applications such as pumps.

7.3 High Efficiency Motor Technology

In order to improve motor-driven system efficiency on a large scale there are two main areas on which to work. First, there is the standardization, classification and legislation part that stimulates the implementation of high efficiency motor systems by imposing voluntary or mandatory minimum efficiency limits based on (inter)national classification and measurement standards (Section 7.2.1). Second, technologic improvements to reduce losses on a system level are necessary. The highest savings can be obtained by matching the motor output to the speed and torque demand of the load by using a variable-speed drive, for example in pumping applications. In a next step, the consumption of the electric motor itself should be reduced by replacing it with a so-called high efficiency motor (HEM). Regarding these HEMs, the question arises as to in which aspects they differ from standard efficiency motors. What is HEM-technology? The answer is difficult to formulate, as there are many possible approaches to improving overall motor efficiency (Figure 7.11) with better materials, design and manufacturing technologies.

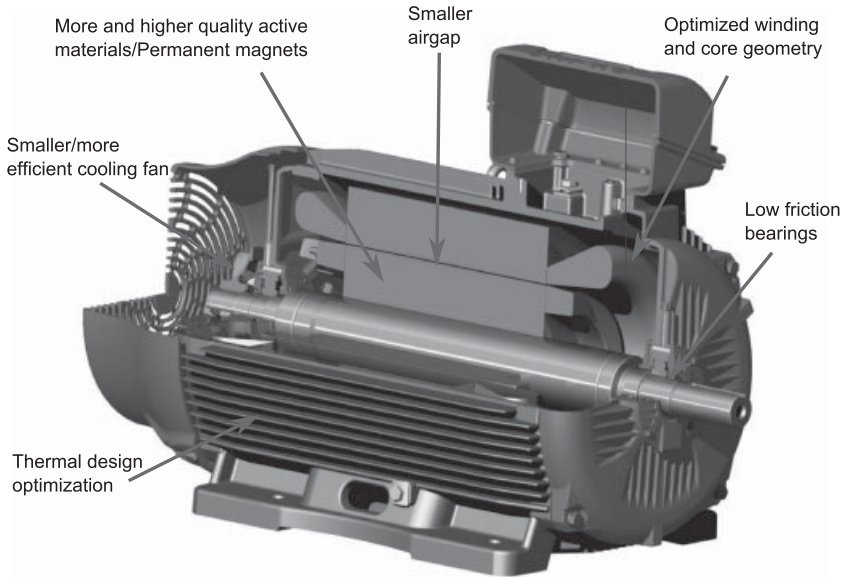

Figure 7.11 Cut-away view of a high efficiency induction motor showing a number of approaches to improving the efficiency. Reproduced by permission of WEG

Motor losses must be reduced while keeping the mechanical output at a constant level. Secondary motor performance characteristics such as starting and breakdown torque, power factor and locked rotor current should also remain within an acceptable range. To accomplish this task, an engineer must thoroughly understand the origin of losses in a motor and identify the main influencing factors, discussed in the first section of this chapter.

The traditional approach to reducing the main losses is simply to add more and higher-quality active materials to an existing motor design. Adding core or conductor material by increasing the main dimensions will respectively lower the flux and current density in the motor, yielding lower iron and joule losses for the same power-output rating. On the other hand, using higher quality materials, such as a high-grade lamination steel or copper instead of aluminium rotor conductors, will give lower losses for the same flux or current density. However, this is a very simplistic approach. Designing an HEM would not be such an advanced problem if the cost of a motor was not a significant design parameter. In the current economic reality, motor purchase cost is of primary concern to customers, especially original equipment manufacturers (OEMs) who have little interest in running costs. The design of a HEM comes down to finding an optimal balance between efficiency and product cost. This is why a well-designed HEM is a fundamentally different motor, built not only with better (and/or more) active materials, but also with optimized geometries and components in order to reduce the material cost considerably. The final factor influencing motor efficiency is the manufacturing and construction process. Improved techniques should have fewer imperfections and allow for smaller tolerances. In the next sections, a comprehensive overview of technological issues concerning motor efficiency, divided in three main categories, is given: motor materials, motor

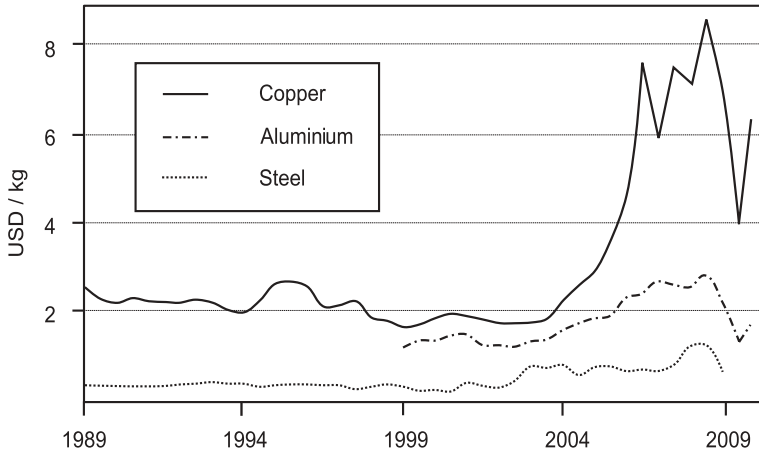

Figure 7.12 Price history of raw materials used in induction motors

design and motor manufacturing. The focus is on three-phase induction motors, the industry's workhorse, but emerging alternative motor technologies are also briefly discussed.

7.3.1 Motor Materials

In the last decades, high efficiency induction motors used standard stator and rotor designs with additional active material by increasing the stack diameter or length. More magnetic steel in the core, copper in the stator windings and aluminium in the rotor cage decreased the losses considerably. Before 2004, copper, steel and aluminium prices were relatively stable and attractive. However, in the last five to ten years quite a turnaround occurred in high efficiency motor development, caused by raw material price swings as a result of global economic changes. Note that Figure 7.12 shows only raw material prices, and finished lamination steel for example is approximately a factor of two more expensive.

Table 7.5 illustrates this evolution by giving a comparison between the material costs of a small 0.75 kW induction motor in the year 2009 versus that in 2000 [23]. The raw material price swings have compromise the cost-effectiveness and have put a hold on HEM development. The key to cost-effective construction of HEMs today is by a close cooperation between material suppliers and motor designers in order to improve the material quality while keeping control of the total cost by optimizing motor-design. Less is more: less material with higher quality combined with a better motor design. Developments and state of the art of core materials, permanent magnets and conductor materials are discussed in the following sections.

7.3.1.1 Core Material

The magnetic circuit formed by the ferromagnetic material of the stator and rotor core is the most expensive part of an induction motor and provides the flux with a low reluctance magnetic path. Compared with paramagnetic and diamagnetic materials, the permeability of

Table 7.5 Comparison of the material cost of a 750 W induction motor in the years 1999 and 2009

Induction motor 750 W	Quantity	1999		2009	
	[kg]	[US\$/kg]	[US\$]	[US\$/kg]	[US\$]
Steel laminations	14	0.9	12.6	1.8	25.2
Copper conductors	1.7	4.5	7.65	9	15.3
Aluminium rotor	0.5	2.2	1.1	4.4	2.2
Total material cost			21.35		42.7

ferromagnetic materials such as construction steel or advanced electrical steel alloys is 100 to even 50 000 times higher. Hence, the magnetizing current and affiliated stator copper losses, required to drive the flux through the circuit will be reduced. It is possible to build a motor with construction steel core material, but the efficiency of such a motor would be insufficient due to the high core losses and the relatively low permeability. Because of the magnetostriction in the core material when subjected to an alternating electric field, loss is generated proportional to the surface of the hysteresis loop. This loss is, according to the Steinmetz equation (7.2), is approximately proportional to the frequency and the flux density B (Tesla) squared. Soft magnetic materials used in motor cores have a narrow hysteresis-loop with a coercive field strength of less than 1000 A/m, yielding smaller hysteresis losses. The eddy-current losses are caused by induced circular currents in the magnetic core and are proportional to the square of frequency and the square of flux density. To reduce these phenomena, a low-conductivity soft magnetic steel with isolated laminations is used (Figure 7.13).

Iron loss and copper loss are related quantities. The mechanical torque produced by a motor is proportional to the active rotor current and the flux. Hence, increasing the non-saturated magnetic flux density with a better highly permeable core material will allow the motor to operate at a higher flux density, reducing active current and copper loss but increasing iron loss. An optimal balance between flux (iron loss) and active torque producing current (copper loss) can be found by design optimizations.

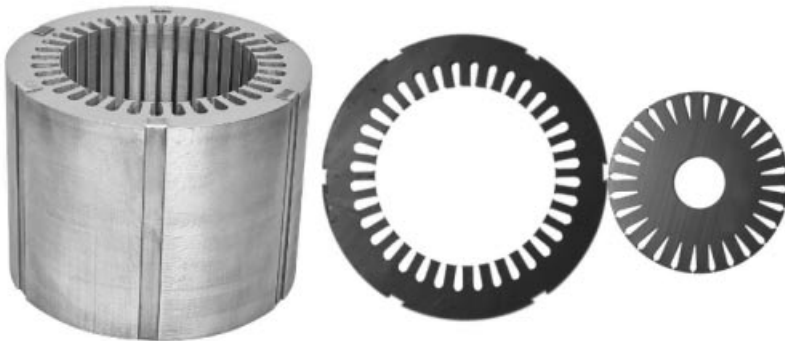

Figure 7.13 Electrical steel laminations are stacked to form the stator and rotor core

Transformers have a fixed flux orientation in the core and therefore use grain-oriented soft-magnetic materials. In motor cores however, the flux direction is variable, so non-oriented soft-magnetic materials are used. They can be divided further according to material composition, ranging from standard silicon steel found in most motors today to more exotic and expensive alloys:

- Silicon steel
- Nickel-iron and cobalt-iron alloy
- Soft-magnetic composites (powder core)
- Amorphous and nano-crystalline magnetic material

To summarize, high-grade core materials have the following properties:

- High magnetic flux density (high permeability): reduce stator copper loss;
- Low conductivity: reduce eddy-current loss;
- Soft-magnetic, low coercivity: reduce hysteresis loss.

In the last 20 years, considerable advancements have been made to improve electrical steel quality for high-efficiency motors [24]. Next, a number of evolutions and core material specifications are given.

Semi-processed and Fully-processed Electrical Lamination Steels

Semi-processed electrical steels are delivered in a cold rolled, un-annealed condition, and must be annealed after punching the laminations to develop optimum magnetic properties [25]. After stamping, the laminations are typically annealed at temperatures between 790 and 845°C for about one hour in a decarburizing atmosphere to recrystallize the microstructure. The objectives of the annealing treatment include:

- Eliminating punching stresses;
- Promoting and controlling grain growth;
- Further reducing impurities, particularly carbon, nitrogen and sulphur.

For example, the non-oriented semi-processed silicon steel with ASTM-code 47S155 has a 0.47 mm thickness with 1.55 W/lb or 3.42 W/kg losses measured in an Epstein-frame at 1.5 T and 60 Hz.

Fully processed electrical steels are intended for applications where the laminations are punched and placed in service without an annealing treatment. The desirable magnetic characteristics are produced during the manufacturing of the steel, so an additional heat treatment by the rotor manufacturer is generally not required. Obviously during the punching of the laminations, the material structure adjacent to the outside cutting edges deforms, but the laminations are used with this sub-optimal microstructure.

Silicon Content

Adding silicon to the electrical steel sheets (FeSi_3) is the most common and effective procedure to decrease the conductivity and eddy-current loss. However, for application in high efficiency motors, the Si-content is limited because it lowers the non-saturated magnetic flux density

(permeability) and increases mechanical hardness, which makes the production more expensive due to increased tooling costs. Low conductivity and high permeability were often regarded as irreconcilable, but work has been done in this area [26] with the development of cobalt and nickel iron alloys.

Interlaminar Insulation

Insulating coatings on the laminations reduce iron loss by restricting the eddy currents to flow in an individual lamination of the core. A wide range of coatings can be classified by the types C0, C1, C2, C3, C4 and C5, with different insulation resistance, heat resistance, punchability and weldability [27]. Most common for small motors are oxide coatings (C0, C1), formed naturally or during the annealing process of punched laminations. However, the interlaminar insulation of the oxide layer is not consistent, which makes it unsuitable for use in high efficiency motors. Basic organic coatings (C3) are more consistent but are not able to withstand annealing temperatures on semi-processed steels. In high efficiency motors, inorganic (C5) and hybrid coatings (C4/C5/C6) are used that have excellent insulation consistency, thermal resistance and punchability [28].

Lamination Thickness

Thinner laminations have less eddy current losses but increase the costs considerably, both for steel suppliers and motor manufacturers. Below 0.5 mm the sheet material becomes difficult to handle and process. Special manufacturing and stacking techniques are required to integrate ultra-thin (0.05–0.2 mm) laminations and insulation layers with package densities (stacking factor) up to 98% [29].

Cobalt-iron and Nickel-iron Alloys

High-grade soft-magnetic materials based on cobalt–iron or nickel–iron alloys have superior properties and offer considerable advantages for high efficiency motors compared with standard silicon–steel [30]. Cobalt–iron has very high magnetic flux density and permeability, which allows lower magnetizing currents (copper losses) for the same core size or higher power densities for equal magnetizing current. Nickel–iron alloys have lower magnetic flux density but also lower losses due to the low coercivity force and high electrical resistivity. Table 7.6 gives a comparison between a typical silicon–iron and high grade nickel and cobalt alloys [29].

Grain Size

The grain size of magnetic steel is of crucial importance for minimizing the iron losses. Smaller grains on the laminations edges due to mechanical processing (punching) will increase hysteresis losses because the friction between magnetic domain walls will be larger. Furthermore, eddy current loss is proportional to grain size. An optimum exists at 100–150 μm [26]. Typical silicon–steel has a grain size of 30 μm before and 50 μm after stress relief annealing, still much smaller than the optimal value. The growth of grains is limited by small inclusions that interact with the grain boundaries. Lowering the amount of small inclusions and coarsening them by adding aluminium and rare-earth elements to molten silicon–steel will improve grain-growth during stress-relief annealing considerably (up to 70 μm).

Table 7.6 Comparison between strip material specifications of silicon–iron, cobalt–iron and nickel–iron

	Lamination thickness	Coercivity force	Electrical resistivity	Induction at $H = 16$ A/cm	Saturation polarization	Loss at 50 Hz (1 T)
	[mm]	[A/cm]	[$\mu \Omega\text{m}$]	[T]	[T]	[W/kg]
Silicon–iron (47F165)	0.47	0.2	0.40	1.45	2.03	1.17
Cobalt–iron	0.2	0.4	0.40	2.25	2.35	0.6
Nickel–iron	0.2	0.04	0.45	1.55	1.55	0.23

Future Developments

Soft magnetic composites (SMC) are being developed as an alternative core material for the classic lamination sheets [31]. SMC is produced by bonding iron powder under pressure with an epoxy or other organic resin in a particular shape. The bonding material provides great strength and insulation properties. SMCs have average to good magnetic properties (permeability) coupled with low eddy-current losses, especially at high frequencies, due to the insulation between the grains provided by the bonding resin. This makes SMC an interesting material to use in high efficiency motors for inverter operation (high-frequency harmonics). The main advantage however is the freedom that SMC gives to the motor designer to make complex core forms with a very smooth surface finish as the electrical resistance is isotropic (unlike laminations), imposing no constraints on the design.

Amorphous magnetic materials (AMM) offer future potential to further reduce iron losses in motor cores. AMM is produced by quenching liquid alloy compositions (Fe, Co, Ni, Si, etc.) rapidly in a very thin layer in order to avoid the normal equilibrium crystalline structure and retain an amorphous disordered structure similar to glass [32]. The advantage of this disordered atomic structure is a very low iron loss due to the high resistance, typically less than 0.2 W/kg at 50 Hz and 1.5 T (2–4 W/kg for silicon steel). The saturation level and permeability is only average because of the need to add glass-forming elements (Si), so slightly larger cores must be used with AMM. The biggest prohibitive factor is still the cost. AMM has the potential to be produced economically in the future, but the brittleness of the extremely thin gauges (0.04 mm max) make AMM difficult to process in terms of cutting out lamination shapes and obtaining a good stacking factor.

7.3.1.2 Rotor Conductor Material

Joule losses ($R I^2$) in the rotor cage account for the second largest portion of loss in an induction motor. Squirrel cage material conductivity, cross-section and length determine the resistance and also the joule losses in the rotor. The choice of highly conductive materials in mass-production motors is limited by cost, excluding exotic materials and leaving the relatively cheap aluminium and the highly conductive copper as the only two feasible options. The rotor cages of induction motors in the small to medium power range are generally pressure die-cast from aluminium because this allows cost effective mass production and fairly good

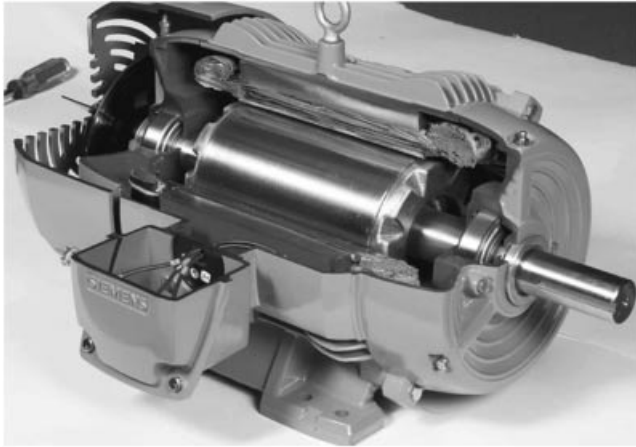

Figure 7.14 High efficiency induction motor with a die-cast copper rotor. Reproduced by permission of Siemens

conductivity and efficiency. The alternative, to use copper for the rotor cage, has gained interest in the last decade, driven by the need to improve motor efficiency according to the MEPS. The 70% higher conductivity of copper can reduce joule losses, leading to a lower operating temperature, again decreasing conductor resistance. Apart from the efficiency benefit, the lower motor temperature allows for a smaller fan with less air friction and will increase motor lifetime according to the empirical law stating that a decrease in 10° operating temperature will extend motor lifetime by a factor of two.

Copper rotors are not a new technology, in fact they are the standard in large power induction motors with fabricated rotor cages built from solid copper bars welded to the end rings. For mass-produced small to medium range induction motors, fabricated copper rotors are not economically feasible but copper die-casting was problematic due to the high melting point of copper. For a long time, this has been a barrier for copper rotor breakthrough, but work has been done in this area by a number of major motor manufacturers to overcome this problem [33]. Today, the technology has reached a mature status able to improve motor efficiency considerably (Figure 7.14). Unfortunately, another barrier was created due to the large increase in the cost of copper the last five years, which has put a serious hold on the cost effectiveness of copper rotors. This is why the market penetration of die-cast copper rotor motors is limited today. Copper rotor technology has considerable and proven energy-saving potential, but the discussion about the economics can still be considered open and the outcome will depend mainly on the future copper price evolution [34].

Copper Die-casting Problems and Solutions

The rotor lamination stack and die inserts are placed in the casting machine and liquid copper is injected under pressure to fill the cavities of the rotor bars and end rings. The higher melting temperature of copper (1083°C) compared with aluminium (660°C) gives rise to a number of difficulties with the die-casting process [33]:

- Heat checking: a thermal fatigue phenomenon caused by the cyclic heating and cooling of the die material. The die surface is in contact with the hot molten copper and is at a higher

temperature than the inner portion of the die. This results in an unequal expansion and a large tensile stress on the die surface leading to cracking and premature die failure. The higher die temperatures can also lead to decarburization and softening of the steel dies. Replacing ordinary die steel with high performance alloys (nickel, tungsten or molybdenum) and using electrical resistance pre-heaters for the dies appeared to be a good solution to these problems.

- Risk of overheating, welding or annealing of rotor laminations, which can compromise material properties.
- Oxidation of the copper melt. For small numbers of castings a shot-by-shot induction melting is appropriate to minimize oxygen exposure. For larger batches, induction melting in an enclosed furnace under a nitrogen atmosphere is necessary.
- Porosity or incomplete casting gives rise to unbalanced rotors and higher stray-load losses. Large pores in the rotor bars locally reduce the cross-section and cause an uneven current distribution in the rotor cage. With 3D fluid flow simulations, optimal casting machine parameters and melt temperature can be calculated to reduce these air inclusions during casting.

Direct Replacement

The most straightforward approach is to leave the stator and rotor lamination stack design unchanged and substitute the aluminium for copper. In [33] this approach was found to give a 1.2% efficiency gain in an 11 kW motor. Other motor characteristics are also influenced by the lower rotor resistance. The torque–speed curve will shift according to Figure 7.15(b), yielding a slight increase in operating speed, lower starting torque, breakdown torque at higher speed and a rise in start-up current. The approximately three times higher mass density of copper compared with aluminium will also considerably increase rotor inertia in a direct replacement. These changes can cause problems for dynamic applications and a non-conformity with motor performance parameters defined in standards. It also should be remarked that copper rotor motors are slightly more vulnerable to voltage unbalance [6]. These negative influences can be reduced by appropriate motor design.

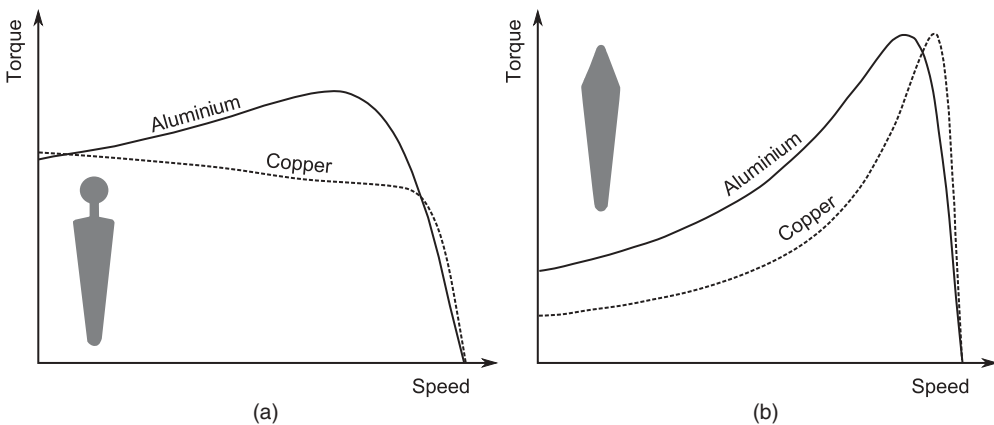

Figure 7.15 Influence of rotor slot geometry on the torque–speed characteristic of aluminium and copper rotor induction motors

Replacement with Rotor Slot Geometry Optimization

The direct replacement of aluminium by copper already significantly improves efficiency, but an even greater enhancement is possible when this substitution is combined with a redesign of the motor, including choice of core material, active part dimensions and rotor slot geometry. The cross-section of the copper bars can be designed to be smaller, so less volume is required, lowering material cost and inertia. Lower starting torque and increased inrush current are expected with a higher rotor conductivity, but by adapting the rotor bar shape, the designer can change motor behaviour to counteract this theory. The key is to make optimal use of the frequency-driven diffusion effects (skin-effects) in the rotor cage [35]. Figure 7.15(right) shows a tapered bar shape used typically in aluminium rotors, maximizing conductor surface with a uniform rotor tooth width to avoid saturation. A double bar slot shape in Figure 7.15(a) will increase apparent rotor resistance at start-up because the electrical frequency seen by the rotor is around the line frequency, forcing the currents to the upper starting bar with a reduced section. This results in an increased start-up torque compared with a conventional slot shape. At running conditions the rotor frequency is low and the currents will flow mainly in the low resistance running bar. It must be remarked that the stray load losses are also influenced by this slot shape as the space and time harmonic frequencies will experience a higher apparent resistance, meaning higher losses.

7.3.1.3 Permanent Magnets

Replacing the rotor squirrel cage of an induction motor with permanent magnets can offer a significant improvement in efficiency. According to the stator winding structure and supply voltage shape (trapezoidal or sinusoidal) this is called a brushless DC (BLDC) or a permanent magnet synchronous motor (PMSM) respectively. The three most common permanent magnet materials are:

- NdFeB: neodymium iron boron (rare earth);
- SmCo: samarium cobalt (rare earth);
- Ferrite (ceramic).

Table 7.7 gives a comparison between the material properties. It is clear that NdFeB is by far superior to the ‘classical’ ceramic magnets in terms of energy density. In [23] it is stated that the available power of a motor varies approximately with the square of the energy product. This translates in more compact and lighter motor designs with NdFeB-magnets.

Table 7.7 Comparison of magnet materials

	Energy product	Coercivity	Remanence	Mass density
	[kJ/m ³]	[kA/m]	[T]	[g/cm ³]
Neodymium iron boron	200–440	750–2000	1–1.4	7.5
Samarium cobalt	120–200	600–2000	0.8–1.1	8.4
Ferrite	10–40	100–300	0.2–0.4	4.5

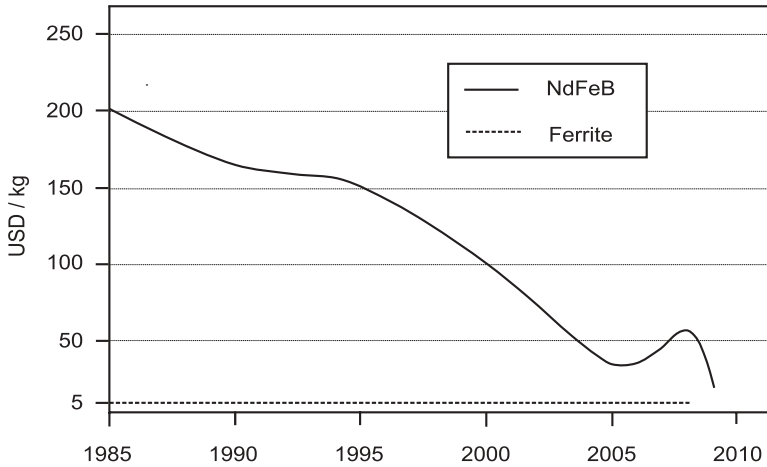

Figure 7.16 Historic price of rare-earth (NdFeB) and ferrite permanent magnet material

Permanent magnets come in many forms, depending on the manufacturing technique:

- Sintered/fully dense: Maximum attainable energy density, limited to simple geometries, brittle
- Compression bonded: Mixture of magnetic powder bonded with a resin, simple geometries, lower energy density, brittle
- Injection moulded: Complex geometric shapes, not brittle, lowest energy density.

Until recent years it was assumed that the use of high energy density (rare earth) magnets in mass-produced motors was economically not feasible. Until the beginning of the 21st century, conductor and core materials were relatively cheap and rare earth magnets expensive (Figures 7.12 and 7.16).

Looking at the changes in the price of materials in the last decade, it is clear that rare earth magnet costs have dropped significantly and copper and steel costs have moved the other way. The drop in the price of NdFeB is due to the proven abundant resources of China. Of course this market-dependency on China as a rare earth magnet supplier also yields risks for future magnet pricing as it is predicted that the market share of permanent magnet motors will continue to increase, for example in electric vehicles. The fact that permanent magnet motors are smaller for the same output power also reduces the need for conductor and core material. The dramatic cost reduction and improvements in magnetic and thermal properties of permanent magnet technology has made it an interesting alternative to induction motors. A comparison between pre-1999 and 2009 material costs of a permanent magnet motor is given in Table 7.8 [23].

7.3.2 Motor Design

The motor efficiency requirements imposed by legislation will increase substantially in time. The straightforward approach of adding active material to meet these efficiency requirements is no longer sufficient or even possible without switching to a larger frame size (shaft height).

Table 7.8 Comparison of the material cost of a 750 W permanent magnet motor in the years 1999 and 2009

PM motor 750 W	Quantity [kg]	1999		2009	
		[US\$/kg]	[US\$]	[US\$/kg]	[US\$]
Steel laminations	6	0.9	5.4	1.8	10.8
Copper conductors	1.1	4.5	4.95	9	9.9
NdFeB magnets	0.3	100	30	50	15
Total material cost			40.35		35.7

Furthermore, motor efficiency is not the only design target that has to be met. Cost and performance specifications are equally important. High efficiency motor design can therefore be considered as a constrained optimization problem of numerous geometry and material parameters [36].

7.3.2.1 Stator, Rotor and Air-gap Geometry Optimization

In the past, the optimization of motor geometry, if executed at all, used to be a trial and error procedure relying mostly on designer experience and rules of thumb. Today, powerful finite-element modelling (FEM) software packages are used as a design tool for the optimization (Figure 7.17).

With FEM-tools it is possible to simulate the electric, magnetic, mechanical and thermal behaviour of a motor in the design stage. Calculated quantities such as flux and current

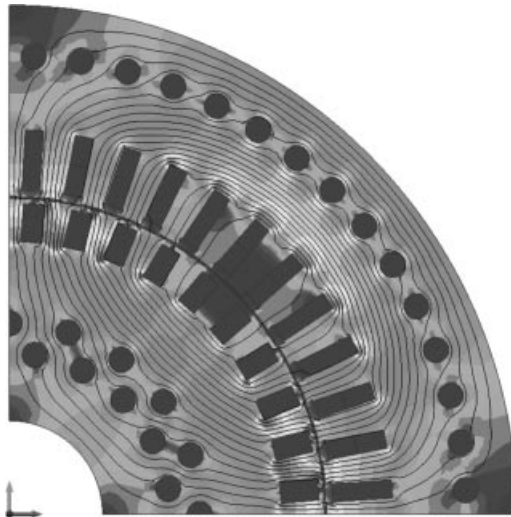
**Figure 7.17** Finite-element model showing the flux lines and the flux density distribution of an induction motor

densities, torque, temperature distribution and losses are the input for an iterative algorithm, which searches for the optimal geometry. The objective of the optimization is to improve the efficiency while decreasing the amount of active material and maintaining motor performance figures within an acceptable range:

- *Core length and diameter*: Output torque is proportional to stack length and the square of the diameter, while iron losses are a function of flux density. Today's optimized HEM-designs yield lower losses with equal or even less volume.
- *Rotor cage geometry*: The shape of the conducting rotor bars in an induction motor determines rotor slip losses. A loss reduction of more than a percent is possible without compromising starting performance or material costs [37]. Skewing of the rotor bars is also often applied to decrease ripple torque caused by space and time harmonics.
- *Air-gap length*: About 70% of the magnetizing current is required to drive the flux through the air-gap of the motor; the remaining 30% is due to the lamination steel permeability. Hence, a smaller air-gap can make a considerable reduction in magnetizing current. Of course, this imposes higher requirements on geometrical tolerances and manufacturing techniques.
- *Stator slot geometry*: This is a crucial optimization exercise between lowering current density in the stator conductors and preventing teeth saturation. Furthermore, stray losses and ripple torque due to slot space harmonics, caused by the chopping of the flux as it crosses the air-gap, can be reduced by adequate slot geometry design.

Typically only a limited number of parameters are optimized with an algorithm. All other dimensions and parameters are constrained to a fixed value because the computing time needed to perform an optimization is proportional to n^2 , with n the number of design variables. A stator slot geometry optimization alone, for example, already has 16 variables [38]. Even with current and future computing performance, an optimization including all design variables will remain a utopia. Because only a partial optimization is carried out, the maximal attainable motor efficiency still depends on basic decisions made by the design engineer. The accuracy versus calculation time ratio of the FEM analysis depends on the level of detail. A 2D-model, for example, will solve much faster than a full 3D-model but parasitic effects of the end windings are not taken into account, unless equivalent circuit impedances are used. The biggest challenge however in the context of accuracy is the modelling of iron losses. Lamination steel loss and permeability data is needed for an extended frequency and induction range to account for the space and time harmonic losses in a motor core. However, the conditions under which lamination steel samples are tested with the Epstein frame are distinctly different from those that the material is subjected to in a motor [39]. The catalogue data is mostly only available for sinusoidal excitation at certain frequencies and a fixed temperature. Furthermore, manufacturing steps will alter the magnetic behaviour locally, which adds even more to the discrepancy between simulations and measurements.

7.3.2.2 Stator Winding Layout

Adding more winding material to a motor lowers the coil resistance and thereby also the stator copper loss. The increase of the copper wire cross-section or the additional windings will, however, create space problems in the stator slots of traditional radial motors. In older

high-efficiency motor designs, the slot width and/or height were increased to provide space for the additional copper. Accordingly, the length and diameter of the core must be increased to keep the flux density and core reluctance the same and to prevent saturation in the teeth. This is of course not an issue in axial flux motors, since windings can be added without affecting the magnetic circuit. Keeping in mind the lamination steel cost, a more interesting approach is to maintain the slot geometry, but to increase the slot fill factor with more advanced winding techniques and wire material. Thinner winding insulation coatings and slot isolation are used to improve the slot fill factor. End winding length is another crucial factor in winding designs because, for small motors, up to 40% of the winding is inactive but loss-producing end winding. In a conventional slotted radial motor, containing a distributed winding, applying a multilayer, chorded winding can reduce end winding length considerably. An interesting evolution in this area is a new construction method for radial motors called segmented core or cut core design. This technique uses individual pole stampings of lamination steel to be assembled into a full radial core. The core segments are wound individually with a concentrated winding, yielding very short end turns and a higher fill factor, which leads to more compact and efficient motors. Up to now, this technique is mainly used in low power motors, since the manufacturing cost is still prohibitive [23].

Next to the previously discussed ohmic losses, the stator winding topology also directly influences harmonic losses (stray losses). Space harmonics are due to the discrete division of windings in slots and time harmonics are caused by non-sinusoidal supply conditions. This leads to non-sinusoidal flux causing lower torque and provoking additional core losses and joule losses in the conductors due to diffusion effects. Full-pitch, non-distributed windings (coil width equal to one pole pitch) generate a significant amount of 7th and 5th harmonics, which are the most harmful to motor performance. By employing multilayer chorded (coil pitch < pole pitch) and distributed windings, these harmonics can be suppressed.

7.3.2.3 Cooling and Thermal Design

The thermal design of an air-cooled high efficiency motor is as equally important as the electrical or mechanical design. Thermal analysis of cooling by conduction, radiation and convection is typically performed with FEM-tools and equivalent thermal resistance networks in which the losses (heat sources) are distributed at the appropriate nodes. Stator and rotor conduction losses are a function of the resistance, which is proportional to the temperature. In [40] the efficiency of a 3.7 kW induction motor was increased with 0.25% by a coil temperature reduction of 10°C. This can be achieved by a reduction of losses in the motor with the previously discussed measures. Next step is better heat conduction from the active parts to the housing components from which the heat is dissipated in the surrounding air. A good thermal contact between the core outside diameter and the housing is crucial, requiring a precise machining of both parts. Another possibility is potting: filling the air cavities inside the frame with an electrically isolating but thermally conductive resin. The housing material and the cooling fin dimensions are also of importance, e.g. an aluminium frame has higher conductivity than cast iron. The next step is the optimization of fan performance. Once again, a trade-off between temperature rise and windage loss can be made, but it must be noted that small HEMs run so cool that a fan is not even needed. For larger motors in applications with a

fixed direction of rotation, it could be interesting to replace the standard bidirectional fan with a higher efficiency unidirectional fan.

7.3.2.4 Bearings

Bearing friction represents a relatively small loss segment, but it is an easy way of gaining a few tenths of percent points in efficiency. Bearing manufacturers provide high efficiency groove-ball bearings that can save 30–50% compared with standard bearings [41]. For a continuously running 7.5 kW four-pole motor this is about 100 kWh per year. The savings are due to the following innovations.

- Non-petroleum greases on a lithium or synthetic basis offer lower losses, longer maintenance intervals and are able to withstand higher temperatures. Maintenance practice is also of crucial importance; over- or under-greased bearings have higher friction leading to premature failure.
- Low friction ceramic ball bearings are another interesting innovation; they run cooler, have a prolonged lifetime and further reduce losses.
- Enclosures of general-purpose motors should meet IP55 requirements as a minimum. Sealed bearings are used but have additional friction, especially in small motors. On the other hand, they allow longer service intervals because the grease is kept in place. Non-contact, low friction seals are the next evolution.
- Friction is proportional to bearing size. For some applications bearing size can be reduced, but shaft loading (for example with belts transmissions) will be limited. In high-efficiency motors the opposite drive end bearing is lightly loaded and can be chosen to be smaller than the drive-end-bearing [24].

7.3.2.5 Alternative Motor Technology

Induction motors (IM) are still the industry's workhorse and represent nearly the entire installed base of constant speed and variable speed general purpose motors [42]. The IM is mature technology, cheap, robust and can reach high efficiencies. Levels exceeding IE3 are possible when material, design and manufacturing are optimized. However, the present and future market for motors places ever increasing value on operating efficiency, power density, low cost and reliability [43]. Since current induction motor technology is reaching the physical boundaries of what is possible in terms of efficiency improvement at reasonable cost, other technologies like permanent magnet (PMSM) or switched reluctance motors (SRM) are considered (Figure 7.18).

SRMs are an alternative in variable speed traction operation, for example in electric or hybrid cars, with a simple and robust rotor structure and a high efficiency. Each motor phase consists of two opposite stator poles carrying concentrated excitation windings. The SRM requires one converter unit per phase. When a motor phase is supplied with DC current, the energized stator pole pair attempts to pull the closest rotor pole pair into alignment, which in turn minimizes the reluctance of the magnetic path. The operating principle is inherently accompanied by vibration, acoustic noise and a relatively high torque ripple. Furthermore, smooth operation of an SRM requires a complex controller and accurate position feedback to

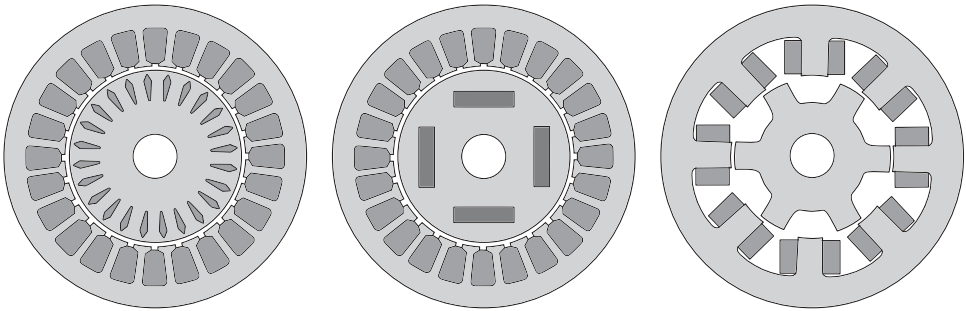

Figure 7.18 The three main AC motor drive technologies, from left to right: induction motor, permanent magnet synchronous motor and switched reluctance motor

profile the current waveforms [44]. This is why SRM technology will probably not replace the IM in standard frame general purpose motors, but is rather to be used in specific variable speed applications in which its benefits can be used to the full advantage.

Another more promising technology that is gaining ground in standard frame general purpose motors is the permanent magnet motor. According to the stator current waveform one can distinguish the brushless DC (BLDC) or permanent magnet synchronous motor (PMSM) with respectively rectangular or sinusoidal current waveforms. Note that the stator of a PMSM has an identical layout to that of an induction motor, with a three-phase distributed or concentrated winding.

PMSMs have a number of substantial benefits over the IM.

- *Higher efficiency:* The permanent magnets in the rotor supply the flux. Practically no magnetizing current flows in the stator winding and no currents are induced in the rotor, reducing the corresponding copper losses. Furthermore, due to the synchronous operation, the flux variation causing the iron losses in the rotor core is, apart from harmonics, zero.
- *Higher power density:* The reduction of losses and the corresponding lower heat generation allows one to increase the stator current keeping the same operating temperature with higher torque output. It is possible to deliver the same output in smaller frames, significantly reducing the weight and volume of the PMSM.
- *Wider speed range with constant torque:* PM motors are more efficient than induction motors throughout the speed range, especially at lower speeds. Therefore, the cooling system efficiency reduction at lower speed is compensated for by the loss reduction, thus allowing constant torque in the entire speed range.
- *Maintenance:* The bearings run cooler, prolonging the lifetime and the lubrication intervals.
- *Inertia:* Reduced rotor weight is an advantage in dynamic applications.

PM motor technology is not new, but was up till now mostly used in servo motors or in special-purpose traction motors in low speed, high torque applications. The improved performance to cost ratio of rare earth (NdFeB) permanent magnet materials has reached a level where the increased efficiency and power density offsets the cost of the magnets [43]. At present, a

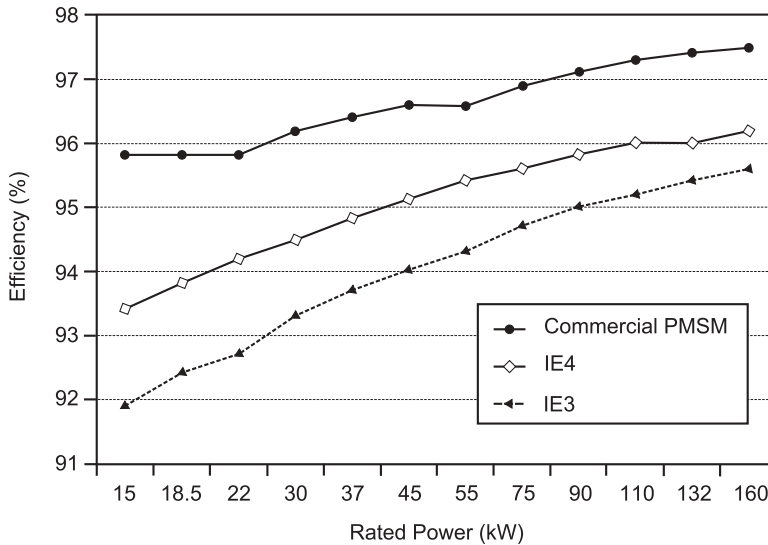

Figure 7.19 Efficiency of a commercially available PMSM range (two pole) compared with the IE3 and IE4 MEPS levels

number of major motor manufacturers offer this technology in a complete range of standard frame general purpose motors for variable speed application, as an alternative for the IM. The efficiency gains are (Figure 7.19) exceeding the current premium (IE3) efficiency level by 2% and comfortably reaching the IE4-level.

A drawback of a PMSM is that it cannot be directly connected to the grid, even for constant-speed applications. It needs an inverter with field-oriented control (FOC) that adds to the losses and cost in a constant speed application. A line start permanent magnet synchronous motor (LSPMSM) is in this case a good solution. It is in fact a hybrid IM/PMSM with permanent magnets in the rotor combined with a squirrel cage at the rotor surface that provides the starting and accelerating torque when connected to the grid. When synchronism with the grid frequency is reached, the motor operates with zero slip, invariant of load, and practically no losses are induced in the cage. The efficiency is 1–2% better than premium efficiency induction motors, but power density is about equal so they come in the same standard frame sizes. This technology is readily available in the catalogues of major manufacturers. It is specifically aimed at a low to medium power range as a direct replacement for induction motors in constant-speed applications. Variable speed (V/f or scalar) control is also possible, but efficiency will be decreased due to the losses induced by switching harmonics in the rotor cage.

7.3.3 Motor Manufacturing

Next to material and design innovations, motor designers are now also turning to the production plant in their search for higher motor efficiency. It is widely recognized that manufacturing and construction techniques have a large influence on the efficiency of the final product.

A motor can be well designed with high quality materials, but the manufacturing must be on the same high level to achieve a quality end-product. This requires a close cooperation between manufacturing engineers and design engineers, a system of quality control during the production stages and investments in plant, tooling and training of manufacturing personnel. Limiting the production tolerances and thereby the efficiency bands is crucial. In the past, designers often added supplementary material to have enough 'buffer' to account for efficiency deviations due to production. This is not an option any more, given the current cost-efficiency requirements. In recent years, a number of loss increasing manufacturing processes have been identified and improved that enabled designers to reduce the amount of material previously added to allow for these variations.

7.3.3.1 Core Manufacturing

Magnetic steel suppliers guarantee the losses and permeability of their products by Epstein frame test data on unmanufactured steel strips, but the properties will deteriorate significantly as the material is transformed into a motor core. 'Manufacturing iron loss' is due to the mechanical and thermal stress to which lamination steels are subjected during motor core manufacturing. Iron losses can almost double, but with an adequate manufacturing process, the influence can be minimized.

- A first possible source of stress is the cutting operation on the thin metal sheets. The microstructure of the steel is affected (smaller grains), which results in a local decrease of permeability and an increase of hysteresis losses of 5–30% in a region of 1–6 mm from the cutting edge [45]. A number of different cutting techniques are used, each with a different influence on the iron loss [46]. Laser cutting is commonly used for small production batches of prototypes or special machines. It is reported to be the worst technique because it subjects the material edges to very high temperatures. Punching is the most common technique and leads to high stress levels in the lamination material. However, when the punching tools are kept in good condition by regrinding on time to prevent burrs and excessive stress in combination with stress relief annealing, the influence can be reduced to an absolute minimum. The best technique, however, is spark erosion with a very low mechanical and thermal impact on the material.
- The core laminations stack is held together under axial pressure by a variety of methods including welding, bolting, cleating or semi-pierce interlocking [47]. Compressive stress should be minimized and welds, cleats or bolts should be positioned in strategic places of low flux density.
- The stator core is often subjected to a large radial force due to the shrink-fit in the housing, which must be reduced to a minimum.

7.3.3.2 Stator Winding

For the stator winding, high slot fills and short tight end windings are important for reducing ohmic losses, but are more difficult to install and insulate. Automatic winding machines often produce random wound coils, which results in a relatively low slot fill and loose end windings. Machines able to produce high density layer wound coils for a specific slot geometry are

necessary. Another possibility to increase slot fill is by reducing the wire insulation volume, which on a 0.8 mm conductor represents 12% of the cross-sectional area [28]. This requires the development of materials with an equal insulation value for a smaller thickness.

7.3.3.3 Rotor Cage Die-casting

Aluminium or copper squirrel cage rotor die-casting is a critical process, in which the filling of the slots and end rings and the purity of the material (air or dirt inclusions) are crucial factors influencing the rotor losses. Furthermore, the cast conductor bars form bridges between the laminations, shorting out the insulation layers. This gives rise to additional stray load and eddy current losses. By making use of the different contraction rates of steel and aluminium/copper, quenching the rotor in cold water after die-casting will cause the two to separate [28]. A better way, however, is to apply an insulating layer to the rotor slots before casting.

7.3.3.4 Geometrical Tolerances

High-efficiency motors are typically designed with a smaller air-gap. This puts higher demands on geometrical tolerances when manufacturing and assembling the parts to prevent vibrations or even collision due to eccentricity. To ensure air-gap concentricity it is common practice to turn the motor to size from the motor shaft centres [28]. The risk exists that laminations are burred together to form a conducting surface over the rotor laminations if the condition of the tooling is insufficient. High frequency rotor surface losses due to the skin effect of space and time harmonics will be doubled if no precautions are taken. For smaller motors, the best solution is to increase the accuracy of the punching operation, so laminations can be punched to size directly. For larger motors this is not practical, and burrs must be avoided or removed. The tolerances on the machining of the frame and bearing end shield will also be tighter to ensure concentricity between the housing inner-surface and the bearing houses.

References

- [1] H. De Keulenaer, R. Belmans and E. Blaustein, *Energy Efficient Motor Driven Systems. Can Save Europe 200 Billion kWh of Electricity Consumption and over 100 Million Tonnes of Greenhouse gas Emissions a Year?*, European Copper Institute, Brussels, Belgium, 2004.
- [2] P. Bertoldi and B. Atanasiu, *Electricity Consumption and Efficiency Trends in the Enlarged European Union – Status report 2006*, European Commission, DG TREN, Joint Research Centre and Institute for Environment and Sustainability, 2007, p. 66.
- [3] A. T. De Almeida, F. J. T. E. Ferreira and J. A. C. Fong, Standards for efficiency of electric motors, *Industrial Electronics Magazine, IEEE*, **17**, 2011, p. 8.
- [4] A. A. Jimoh, R. D. Findlay and M. Poloujadoff, Stray losses in induction machines: Part I, Definition, origin and measurement, *IEEE Transactions on Power Apparatus and Systems*, **PAS-104**, 1985, pp. 1500–1505.
- [5] A. A. Jimoh, R. D. Findlay and M. Poloujadoff, Stray losses in induction machines: Part II, Calculation and reduction, *IEEE Transactions on Power Apparatus and Systems*, **PAS-104**, 1985, pp. 1506–1512.
- [6] W. Deprez, *Energy Efficiency of Induction Machines: A Critical Assessment*, KU Leuven, 2008.
- [7] H. Auinger, Efficiency of electric motors under practical conditions, *Power Engineering Journal* see also *Power Engineer*, **15**, 2001, pp. 163–167.
- [8] H. Auinger, Determination and designation of the efficiency of electrical machines, *Power Engineering Journal* see also *Power Engineer*, **13** 1999, pp. 15–23.

- [9] P. Pillay, P. Hofmann and M. Manyage, Derating of induction motors operating with a combination of unbalanced voltages and over or undervoltages, *IEEE Transaction on Energy Conversion*, **17**, 2002, pp. 485–491.
- [10] S. Van Haute, A. Malfait, R. Reekmans and R. Belmans, Losses, audible noise and overvoltages in induction motor drives, *III Power Electronics Specialists Conference*, Atlanta, Georgia, 1995.
- [11] F. J. T. E. Ferreira, P. Pereirinha and A. T. de Almeida, Study on the bearing currents activity in cage induction motors using finite-element method, *i ICEM 2006, XVII International Conference on Electrical Machines*, Chania, Crete, Greece, 2006.
- [12] B. Bolsens, J. Knockaert, J. V. d. Keybus and R. Belmans, Common-mode poles and eigenmodes for various grounding configurations in motor applications with variable speed drives, *16th International Conference on Electrical Machines (ICEM 2004)*, Cracow, Poland, 2004.
- [13] A. Boglietti, A. Cavagnino, M. Lazzari and M. Pastorelli, International standards for the induction motor efficiency evaluation: a critical analysis of the stray-load loss determination, *IEEE Transactions on Industry Applications*, **40**, 2004, pp. 1294–1301.
- [14] W. Deprez, Understanding the pitfalls between efficiency measurement standards and the practical performance of motor driven systems (invited paper), *Journades Europees d'Energia a l'ITSEIB* Barcelona, Spain, 2007.
- [15] B. Renier, K. Hameyer and R. Belmans, Comparison of standards for determining efficiency of three phase induction motors, *IEEE Transactions on Energy Conversion (IF 0.360)*, **14**(3), 1999, pp. 512–517.
- [16] A. Nagorny, A. K. Wallace and A. V. Jouanne, Stray load loss efficiency connections, *Industry Applications Magazine, IEEE*, **10**, 2004, pp. 62–69.
- [17] P. Van Roy and R. Belmans, Assessment of efficiency of low voltage, three phase motors, *Energy Efficiency in Motor Driven Systems (EEMODS'02)*, Treviso, Italy, 2002.
- [18] A. T. de Almeida, *European Ecodesign Directive on Energy – Using Products (EuPs) – Project: Lot 11 Motors*, 2006.
- [19] P. Angers, Comparison of existing standard methods of determining energy efficiency for three-phase cage induction motors, *EEMODS'09: Energy Efficiency in Motor Driven Systems*, Nantes, France, 2009.
- [20] W. Deprez, J. Lemmens, D. Vanhooydonck, W. Symens, K. Stockman, S. Deryne and J. Driesen, Iso efficiency contours as a concept to characterize variable speed drive efficiency, *XIX International Conference on Electrical Machines (ICEM)*, 2010, pp. 1–6.
- [21] M. Doppelbauer, Guide for the selection and application of energy-efficient motors, *EEMODS '09: Energy Efficiency in Motor Driven Systems*, Nantes, France, 2009.
- [22] A. I. de Almeida, C. U. Brunner, P. Angers and M. Doppelbauer, Motors with adjustable speed drives: testing protocol and efficiency standard, *EEMODS '09: Energy Efficiency in Motor Driven Systems*, Nantes, France, 2009.
- [23] J. Petro, Cost-effective construction of high efficiency motors, *EEMODS*, Nantes, 2009.
- [24] J. Malinowski, J. McCormick and K. Dunn, Advances in construction techniques of AC induction motors: preparation for super-premium efficiency levels, *IEEE Transactions on Industry Applications*, **40**, 2004, pp. 1665–1670.
- [25] Copper Development Association, Copper Motor Rotor Project, 2010.
- [26] M. Takashima, N. Morito, A. Honda and C. Maeda, Nonoriented electrical steel sheet with low iron loss for high-efficiency motor cores, *IEEE Transactions on Magnetics*, **35**, 1999, pp. 557–561.
- [27] M. Lindenmo, A. Coombs and D. Snell, Advantages, properties and types of coatings on non-oriented electrical steels, *Journal of Magnetism and Magnetic Materials*, 2000, pp. 79–82.
- [28] D. Walters, Energy efficient motors saving money or costing the earth? Part I, *Power Engineering Journal*, **13**, 1999, pp. 25–30.
- [29] Vacuumschmelze, Application notes: VAC alloys for motor and generator applications, 2010.
- [30] E. Krol and R. Rossa, Modern magnetic materials in permanent magnet synchronous motors, *Electrical Machines (ICEM)*, 2010 *XIX International Conference on*, pp. 1–3.
- [31] G. Cvetkovski and L. Petkovska, Performance improvement of PM synchronous motor by using soft magnetic composite material, *IEEE Transactions on Magnetics*, **44**, 2008, pp. 3812–3815.
- [32] L. A. Johnson, E. P. Cornell, D. J. Bailey and S. M. Hegyi, Application of low loss amorphous metals in motors and transformers, *IEEE Transactions on Power Apparatus and Systems*, **PAS-101**, 1982, pp. 2109–2114.
- [33] *Technology Transfer Report – The Die-Cast Copper Motor Rotor*, Copper Development Association and International Copper Association, April 2004.
- [34] A. Boglietti, A. Cavagnino, L. Feraris and M. Lazzari, Energy-efficient motors, *Industrial Electronics Magazine, IEEE*, **2**, 2008, pp. 32–37.

- [35] J. L. Kirtley, J. G. Cowie, E. F. Brush, D. T. Peters and R. Kimmich, Improving induction motor efficiency with die-cast copper rotor cages, *Power Engineering Society General Meeting, 2007. IEEE*, 2007, pp. 1–6.
- [36] J. F. Fuchsloch, W. R. Finley and R. W. Walter, The next generation motor, *Industry Applications Magazine, IEEE*, **14**, 2008, pp. 37–43.
- [37] D. G. Walters, I. J. Williams and D. C. Jackson, The case for a new generation of high efficiency motors—some problems and solutions, *Electrical Machines and Drives, 1995. Seventh International Conference on (Conf. Publ. No. 412)*, 1995, pp. 26–31.
- [38] A. M. Knight and C. I. McClay, The design of high-efficiency line-start motors, *IEEE Transactions on Industry Applications*, **36**, 2000, pp. 1555–1562.
- [39] A. Boglietti, A. Cavagnino, D. M. Ionel, M. Popescu, D. A. Staton and S. Vaschetto, A general model to predict iron losses in PWM inverter-fed induction motors, *IEEE Transactions on Industry Applications*, **46**, 2010, pp. 1882–1890.
- [40] M. K. Yoon, C. S. Jeon and S. K. Kauh, Efficiency increase of an induction motor by improving cooling performance, *IEEE Transactions on Energy Conversion*, **17**, 2002, pp. 1–6.
- [41] M. Janssens, SKF Energy Efficient deep groove ball bearings for higher driveline efficiency, *EEMODS*, Nantes, 2009.
- [42] X. Feng, L. Liu, J. Kang and Y. Zhang, Super premium efficient line start-up permanent magnet synchronous motor, *2010 XIX International Conference on Electrical Machines (ICEM)*, pp. 1–6.
- [43] M. Melfi, S. Evon and R. McElveen, Induction versus permanent magnet motors, *Industry Applications Magazine, IEEE*, **15**, 2009, pp. 28–35.
- [44] Z. Q. Zhu and D. Howe, Electrical machines and drives for electric, hybrid and fuel cell vehicles, *Proceedings of the IEEE*, **95**, 2007, pp. 746–765.
- [45] L. Vandenbossche, S. Jacobs, F. Henrotte and K. Hameyer, Impact of cut edges on magnetization curves and iron losses in e-machines for automotive traction, *25th World Battery, Hybrid and Fuel Cell Electric Vehicle Symposium & Exhibition*, Shenzhen, China, 2010.
- [46] W. M. Arshad, T. Ryckebusch, F. Magnussen, H. Lendenmann, B. Eriksson, J. Soulard and B. Malmros, Incorporating lamination processing and component manufacturing in electrical machine design tools, *Industry Applications Conference, 2007. 42nd IAS Annual Meeting. Conference Record of the 2007 IEEE*, 2007, pp. 94–102.
- [47] D. Miyagi, K. Miki, M. Nakano and N. Takahashi, Influence of compressive stress on magnetic properties of laminated electrical steel sheets, *IEEE Transactions on Magnetics*, **46**, 2010, pp. 318–321.